

Portfolio
Chiara Huber
2021

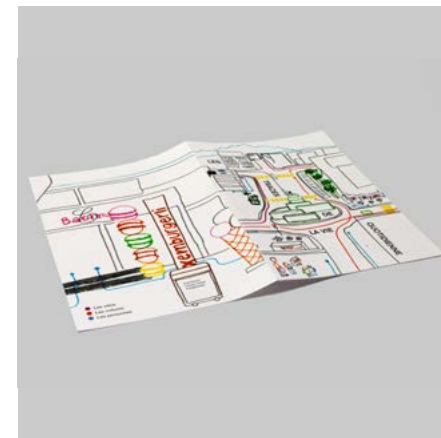

012345689
abcdefghijklmnop
nopqrstuvwxyz
äöü-.,!@®

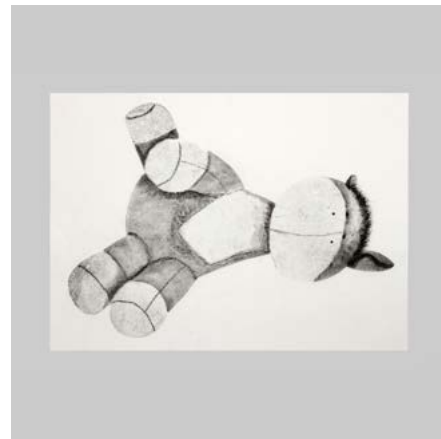

abc c d e f f g g
g h h i j k l m n o
p q q r r s t u v
w x y z f t e g s



Farbstudium Farbe	33	63	Anamorphose Typografie, Film, Fotografie	22	Shelf by Shelf Layout, Editorial, Zeichnen	75	Chiara Huber Grafikerin Luzern
		3	Luftschlangen Illustration, Farbe, Siebdruck				
66	Lens font Illustration, Font - Design			43	Die Spuren des Alltags Layout, Fotografie, Zeichnen		
		17	Errinnerungen Zeichnen, Drucktechnik			54	Die Damen sind die Stärksten Layout, Zeichnen
		49	Kalligrafie Typografie, Kalligrafie			39	Masterabschluss - konzerte Typografie, Illustration
Wegsehen Fotografie, Layout, Typografie	8			72	Stressful Mornings Illustration, Vektor		



Luftschlangen

Illustration, Siebdruck, Farbe

Januar 2021

Unser Auftrag bestand darin Korrespondenzkarten für die Fachklasse Grafik Luzern zu gestalten. Postkarten, die man beispielsweise für Geburtstage oder bei anderen speziellen Gelegenheiten verschicken kann. Festliche Anlässe verbinde ich automatisch mit farbigen Luftschlangen. Ich nutzte die Papierreste, welche vom Zuschneiden meiner mit Siebdruck gedruckten Postkarten zurückblieben und verzog diese mittels Scanner. Es entstand eine Serie von Scans, die ich anschliessend übereinander schichtete und zu einer Postkarte zusammenfügte. Die Karte wurde anschliessend im Offsetverfahren mit drei Farben gedruckt.





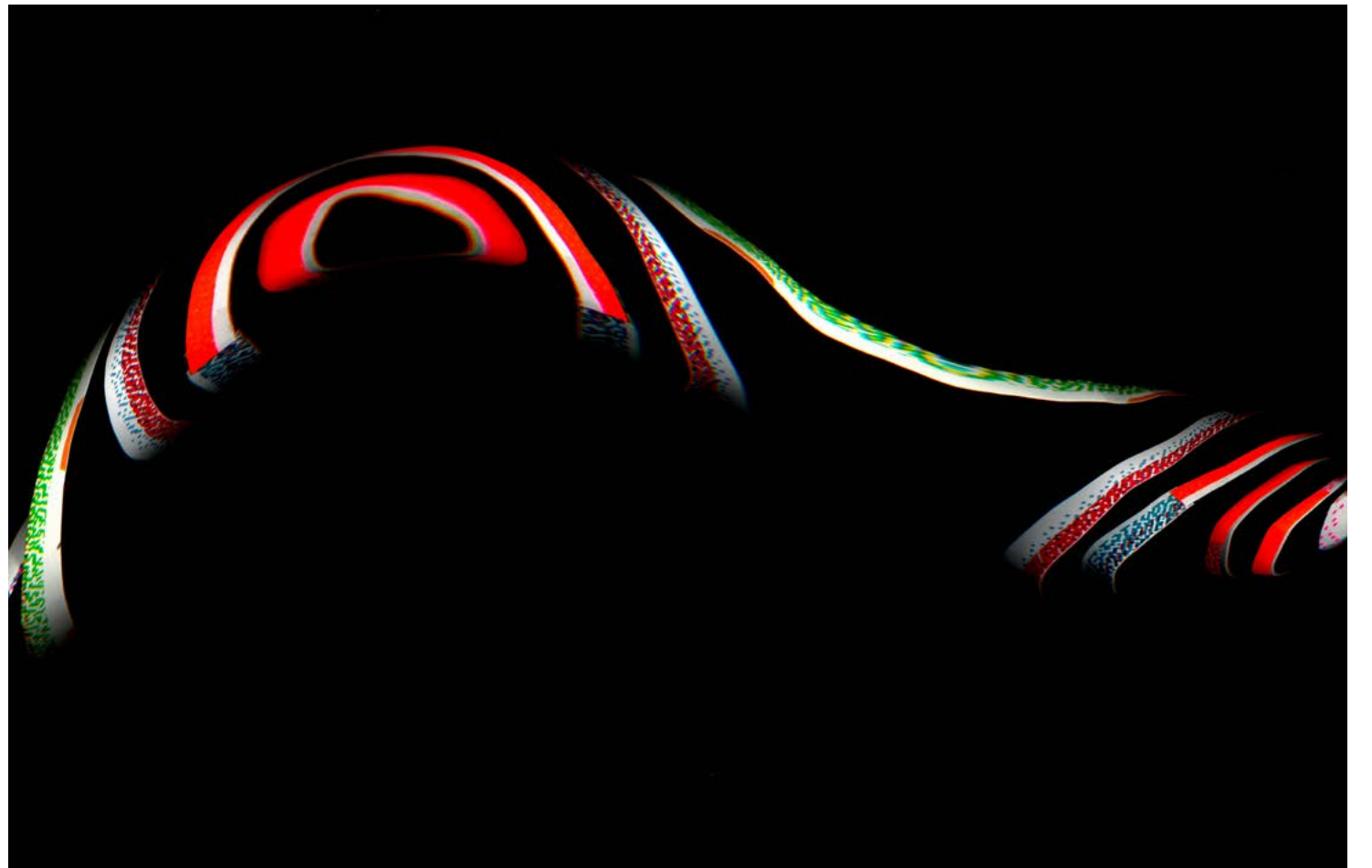
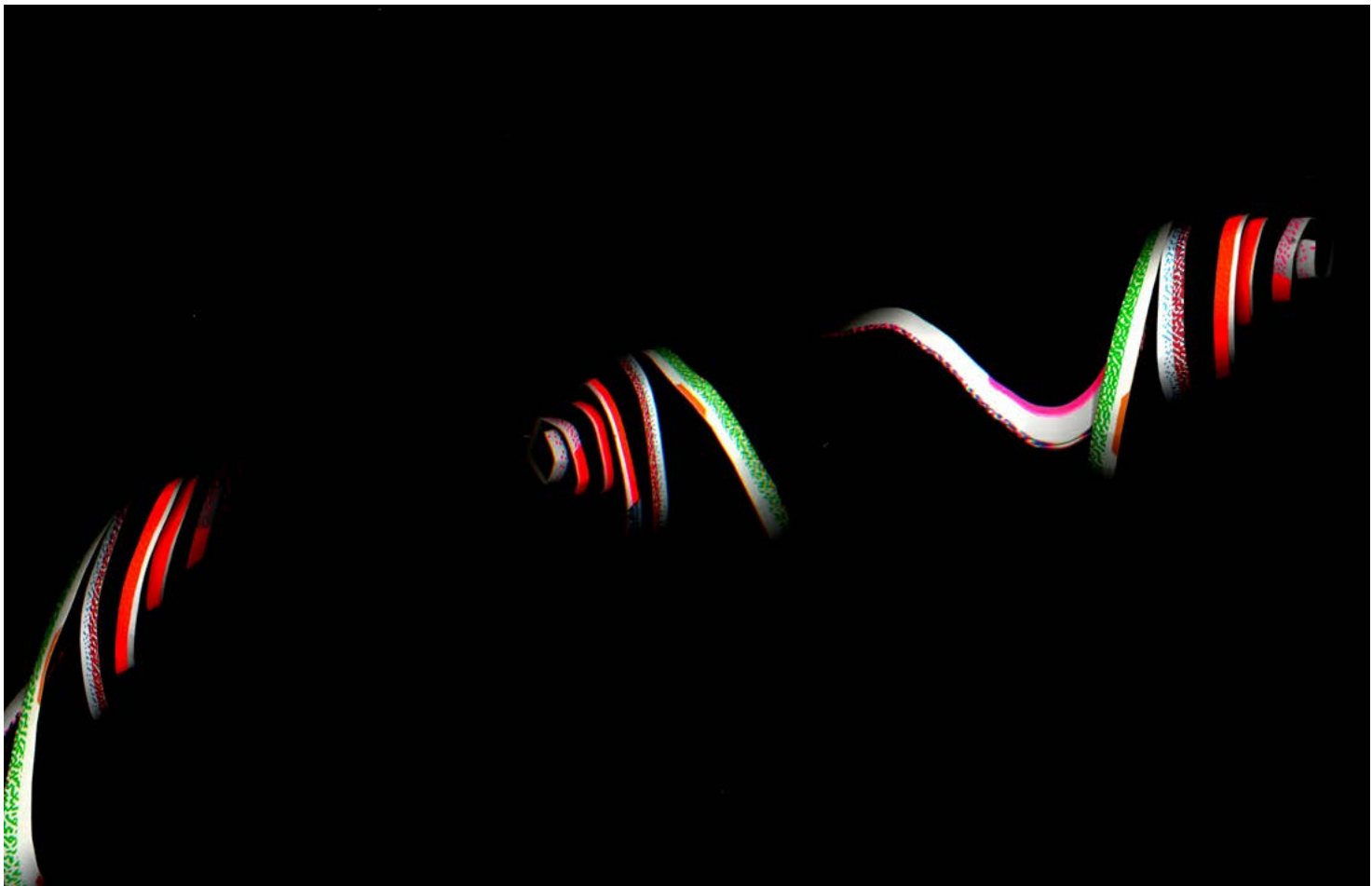
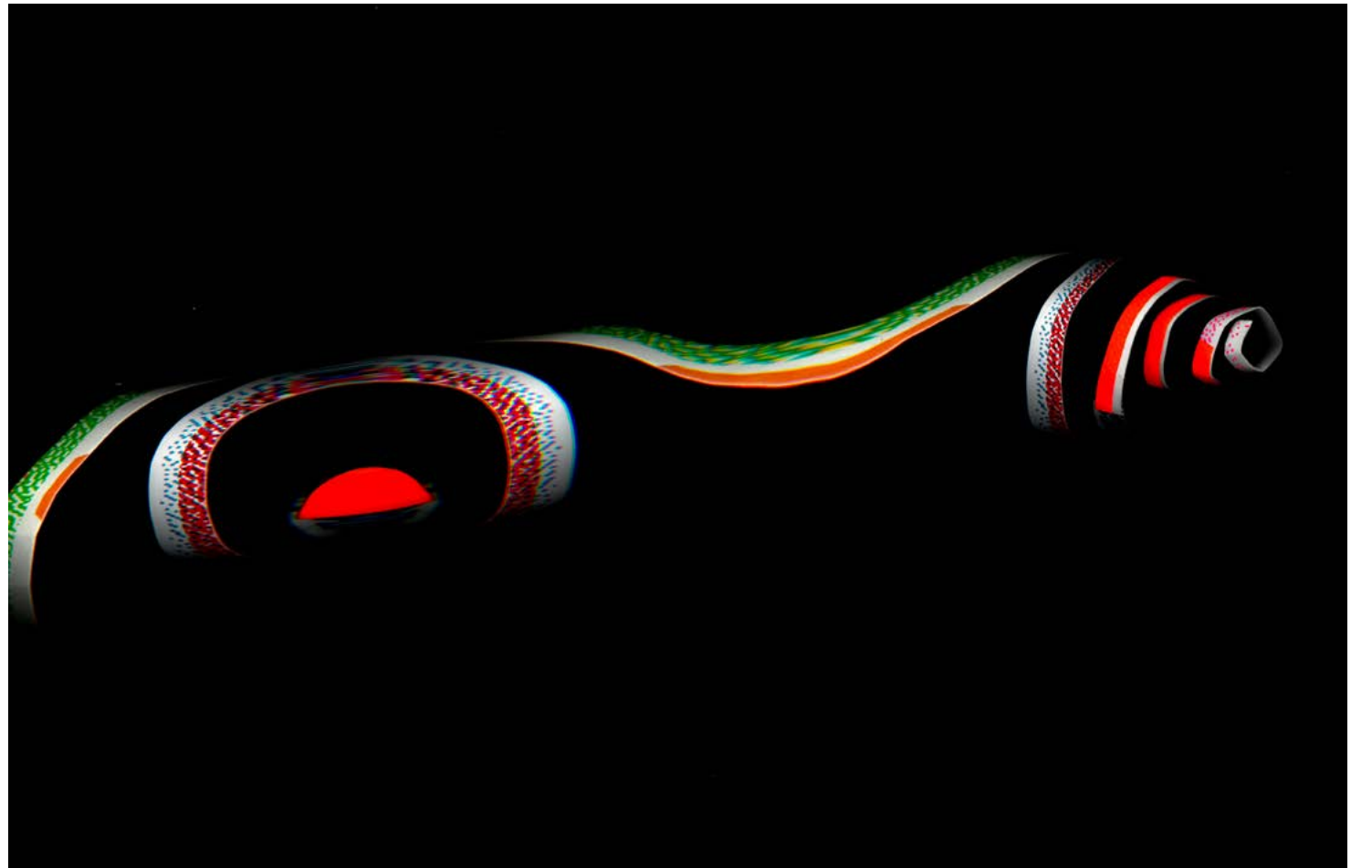
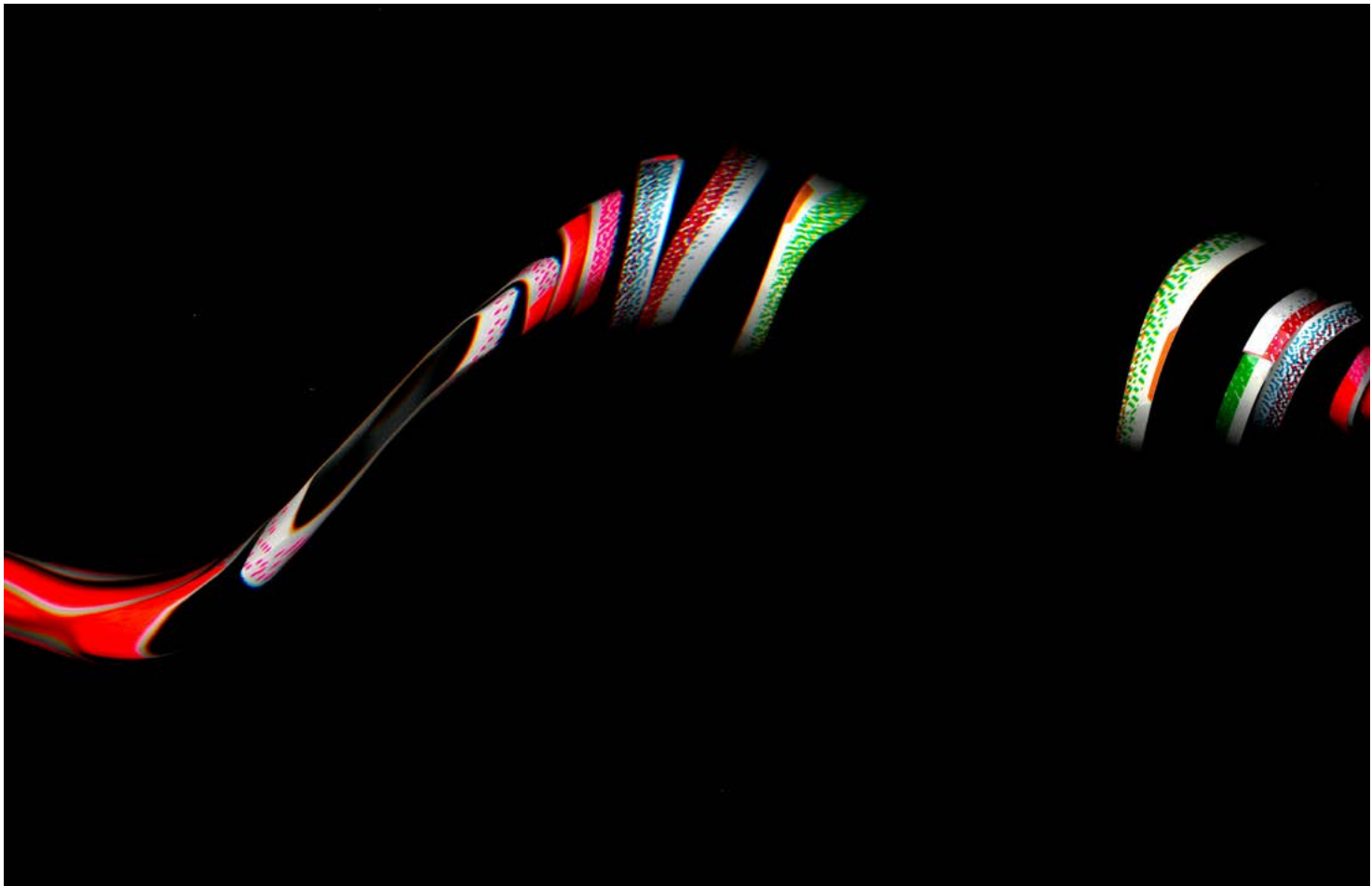





Wegsehen

Fotografie, Typografie

März 2021

Respekt. Ein grosses und wichtiges Thema. Was bedeutet Respekt in unserer Gesellschaft? Mit dieser Frage setzten wir uns auseinander. Ich untersuchte das Thema «Wegsehen» bei Mobbing mittels Fotografie. Mobbing ist heute mehr denn je ein Riesenthema. Die Aussage «Wegsehen heisst mitmachen» inspirierte mich dabei. Das grosse Schweigen rund um die Mobbing - Thematik ist eines der grössten Hindernisse, um Mobbing gezielt zu stoppen. Meine Fotografien zeigen die Ausgrenzung, die Unsicherheit, das Unverständnis, die Isolierung und das Wegsehen. In einem analogen Prozess gestaltete ich anschliessend eine Zeitung und kombinierte diese Fotoserien mit Typografie – um alle zum «Hinschauen» zu bewegen.

HINSEHEN

WZHDV

Gestaltung: Chara Kubler - Wegmannen - Ein Beitrag im Rahmen des Projektes Fotografix zum Thema «Blickpunkt in der Gesellschaft» - Fachklasse Grafik, Luzern FMZ, 2001 - Text: Norbert von Tiggelen





Keine Zeit für liebe Worte, für ein wenig Mitgefühl.

In den Herzen stilles Schweigen,
Lebenslust meist fad und kühl.



Keine Zeit für Diskussionen, es lebe hoch das Vorurteil.

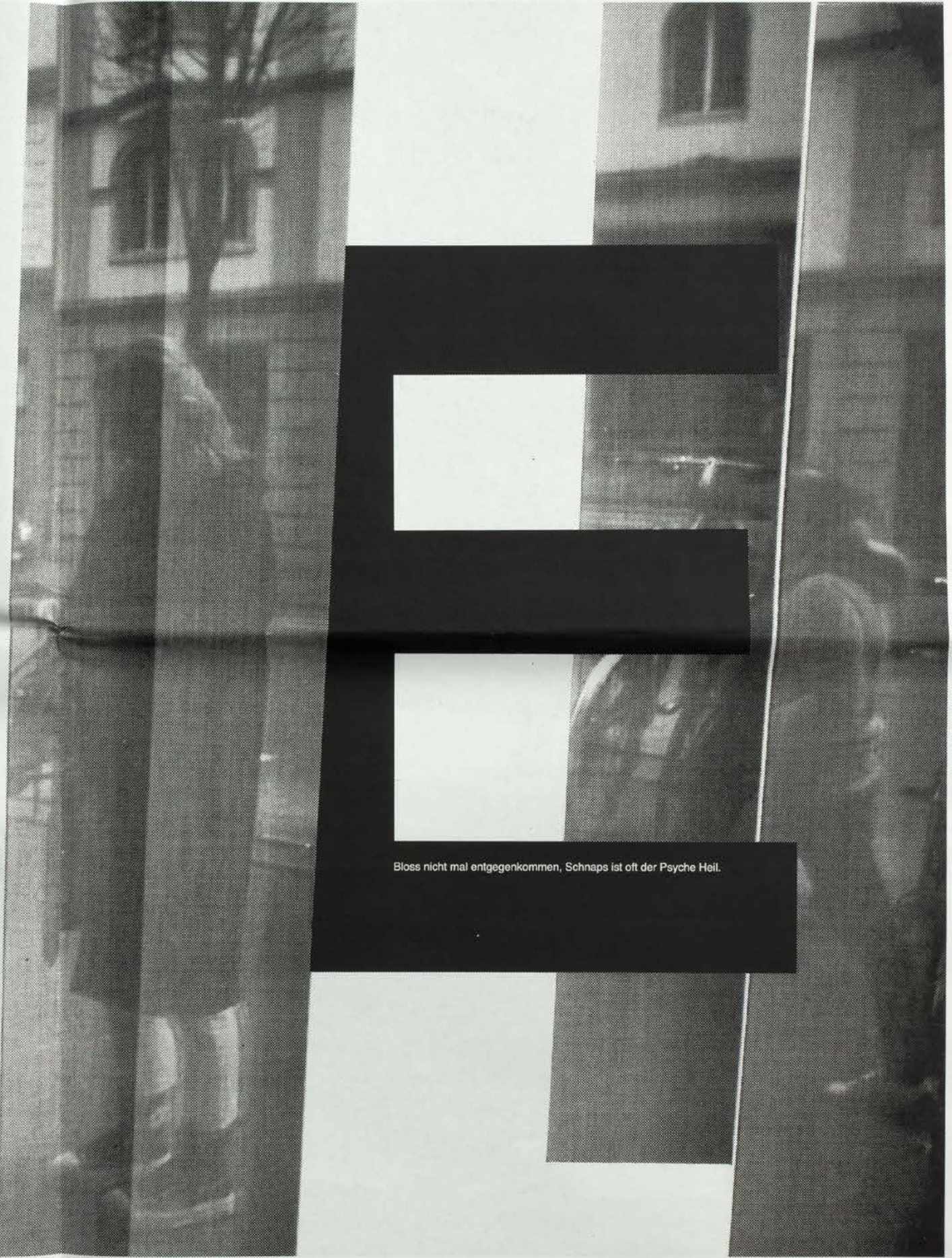

Bloss nicht mal entgegenkommen, Schnaps ist oft der Psyche Heil.

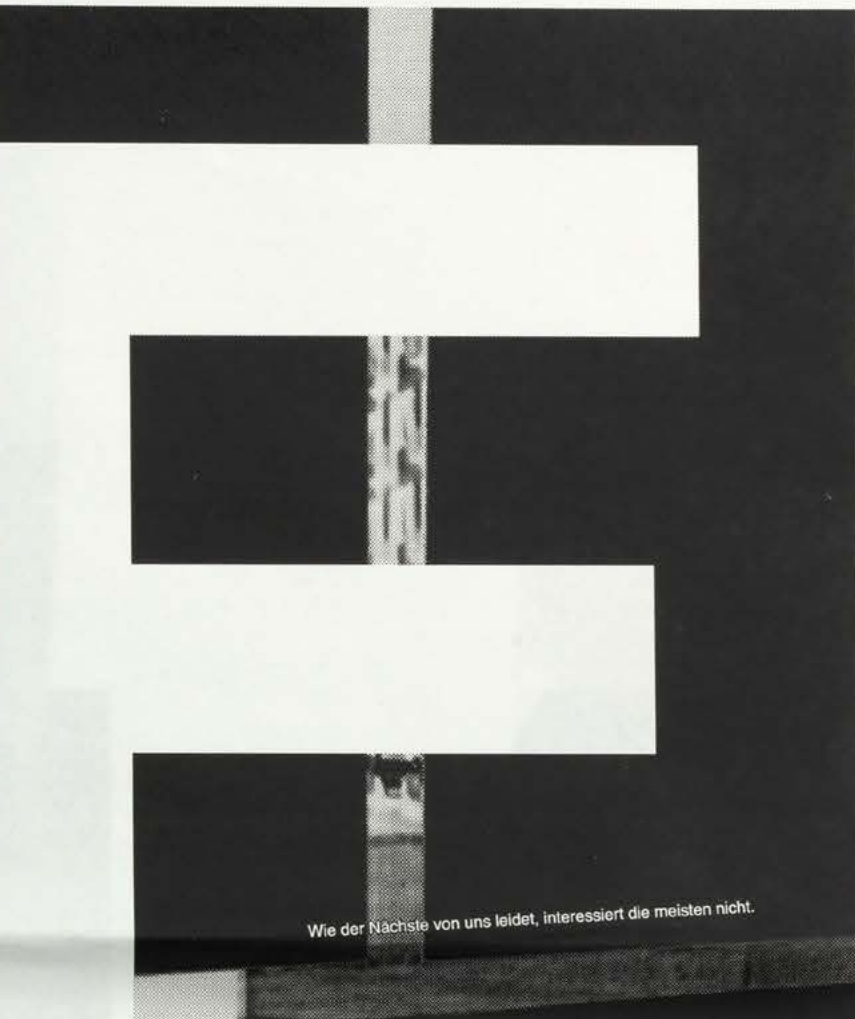
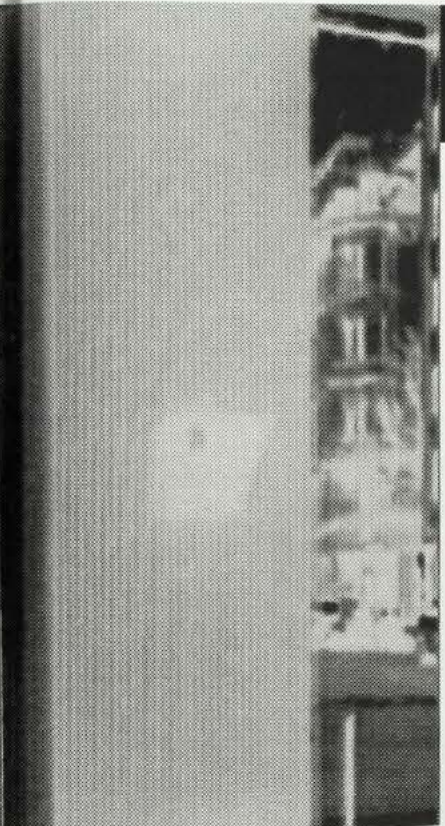

Wie der Nächste von uns leidet, interessiert die meisten nicht.

Keine Zeit für klare Blicke, in den Augen starre Sicht.

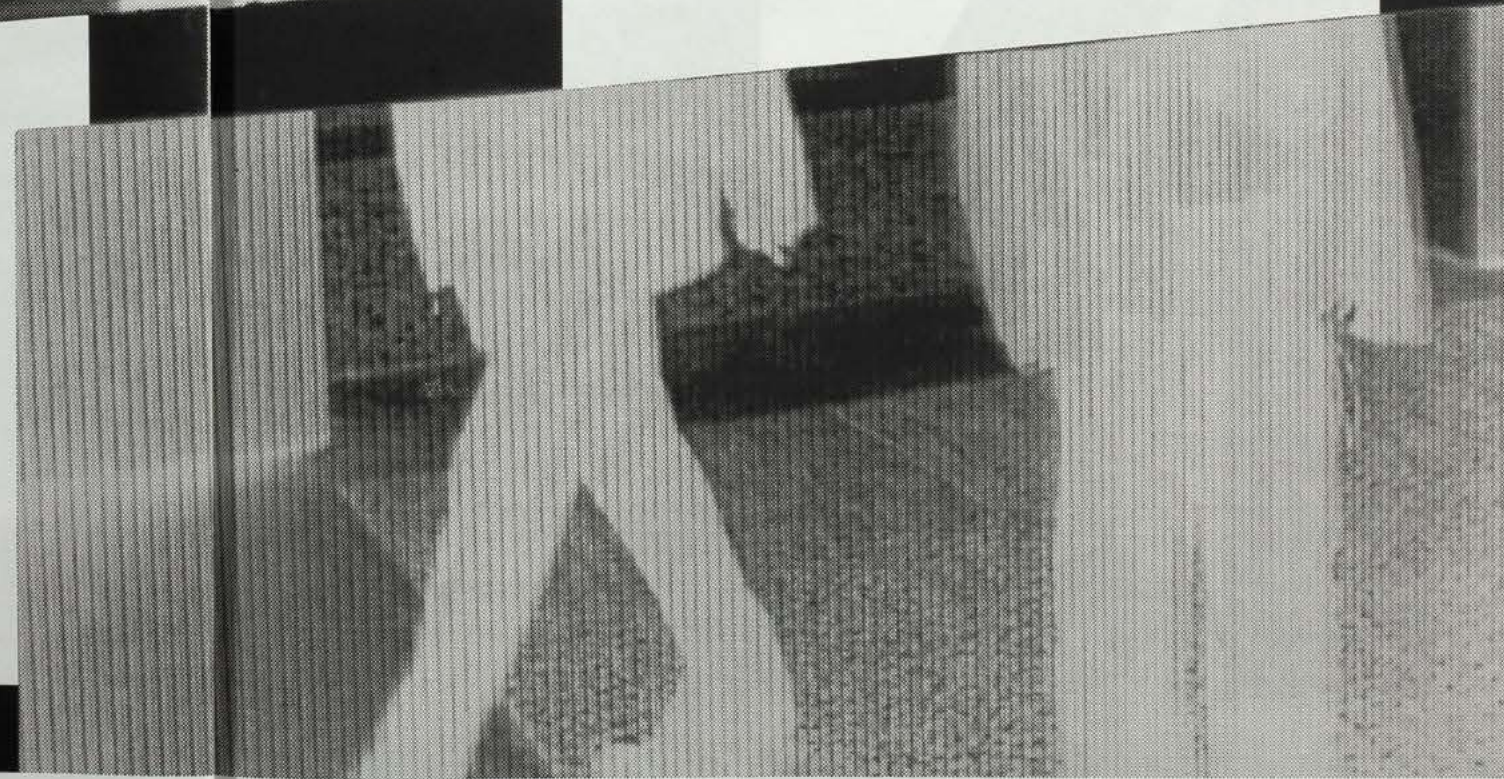

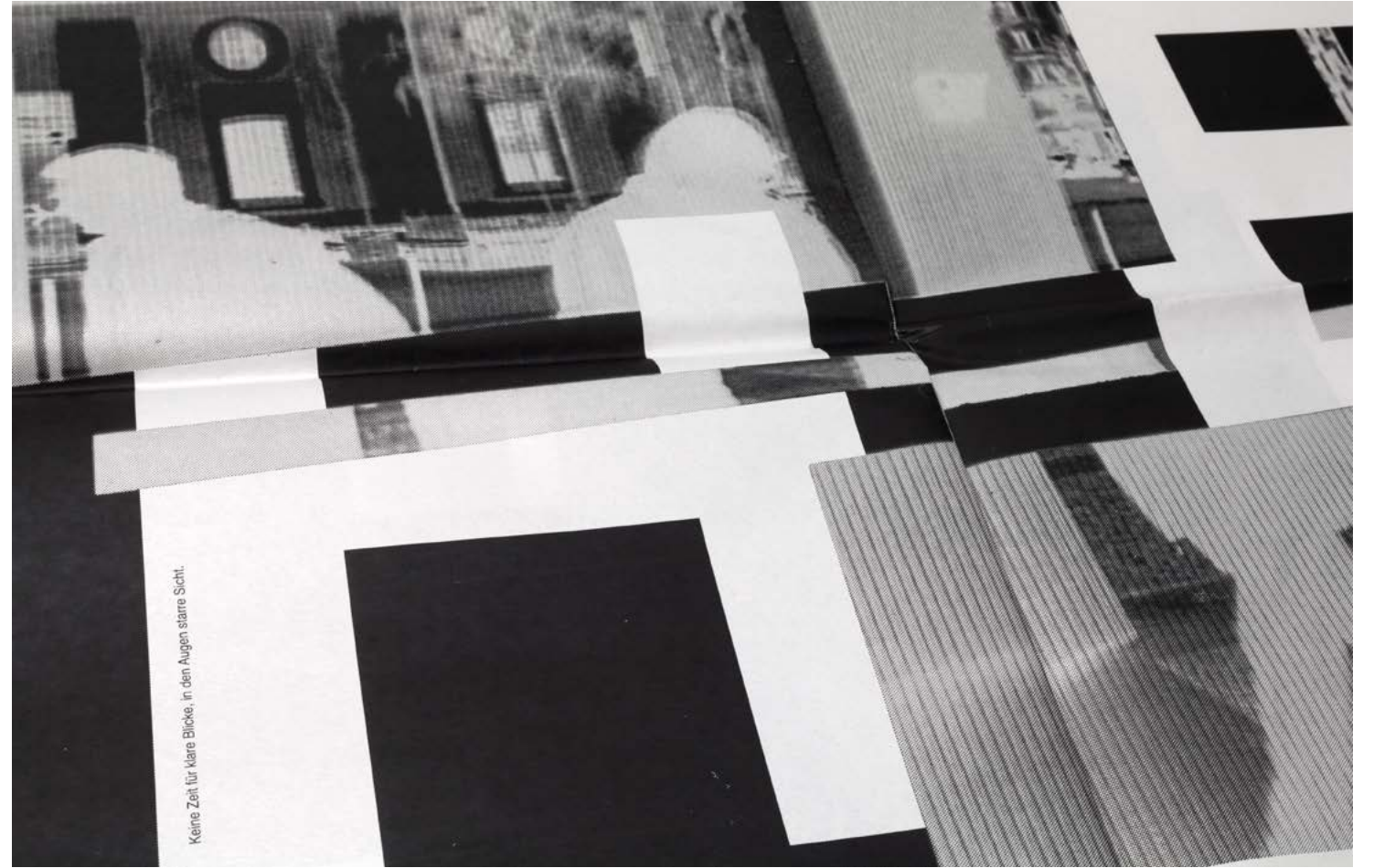

HINSEHEN

WIRTSCHAFTS

Text: Norbert van Tiggelen

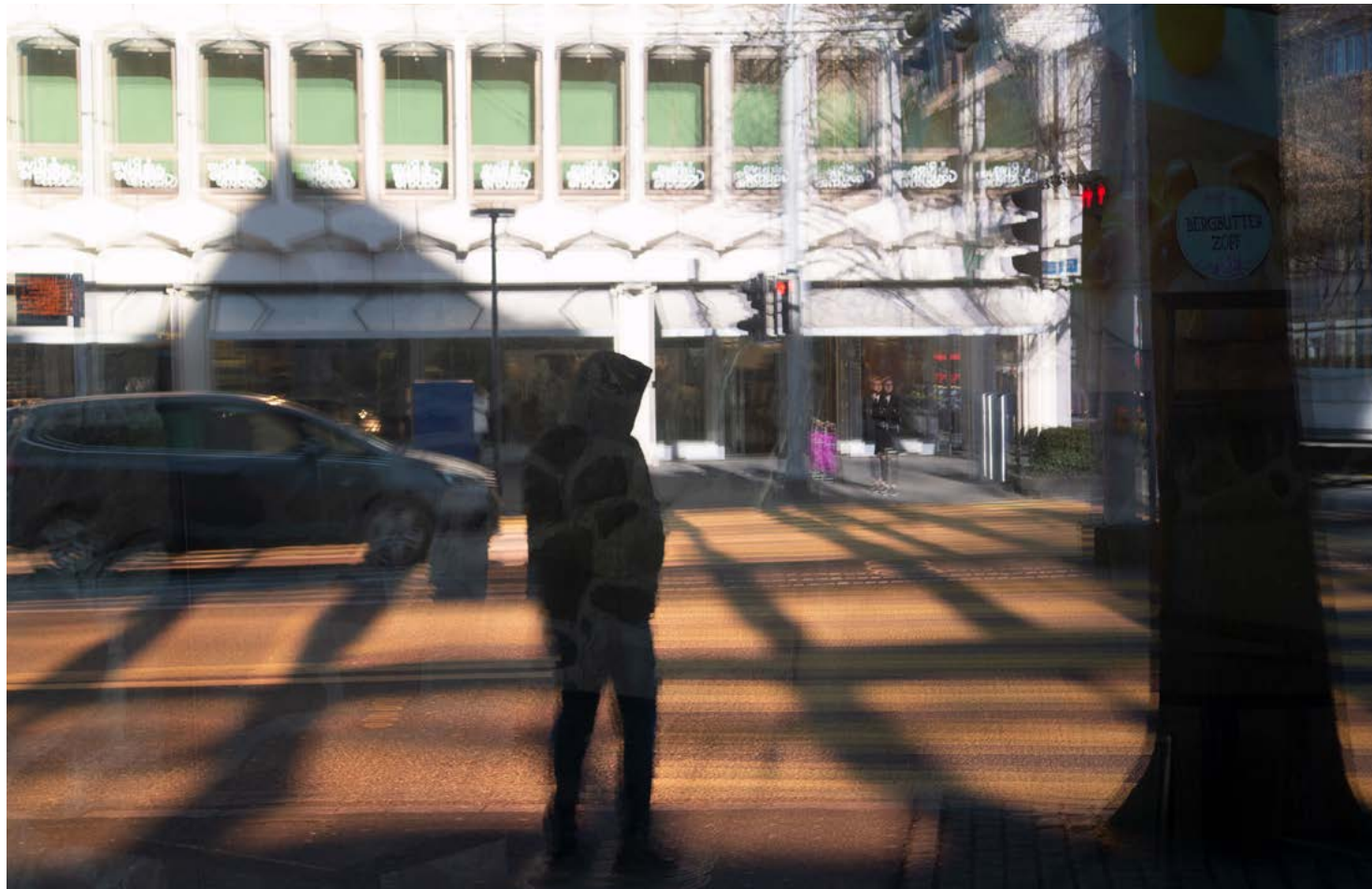





Erinnerungen

Zeichnen, Drucktechnik

Januar 2020

Das Ziel war es, ein selbst gewähltes Erinnerungsstück aus der Kindheit zu porträtieren. Ich entschied mich für mein altes Kuscheltier, das ich in einem ersten Schritt zeichnerisch nach Materialität, Volumen, Funktion und Strukturen untersuchte. Ich wollte dem Betrachter diesen kuscheligen, flauschigen und süssen Esel genauso vermitteln, wie ich ihn in meiner Kindheit wahrgenommen habe. Für die Umsetzung nutze ich die Drucktechnik Monotypie und beschäftigte mich vor allem mit der Darstellung der Struktur des Felles. Details und Verfeinerungen machte ich anschliessend mit Tusche.

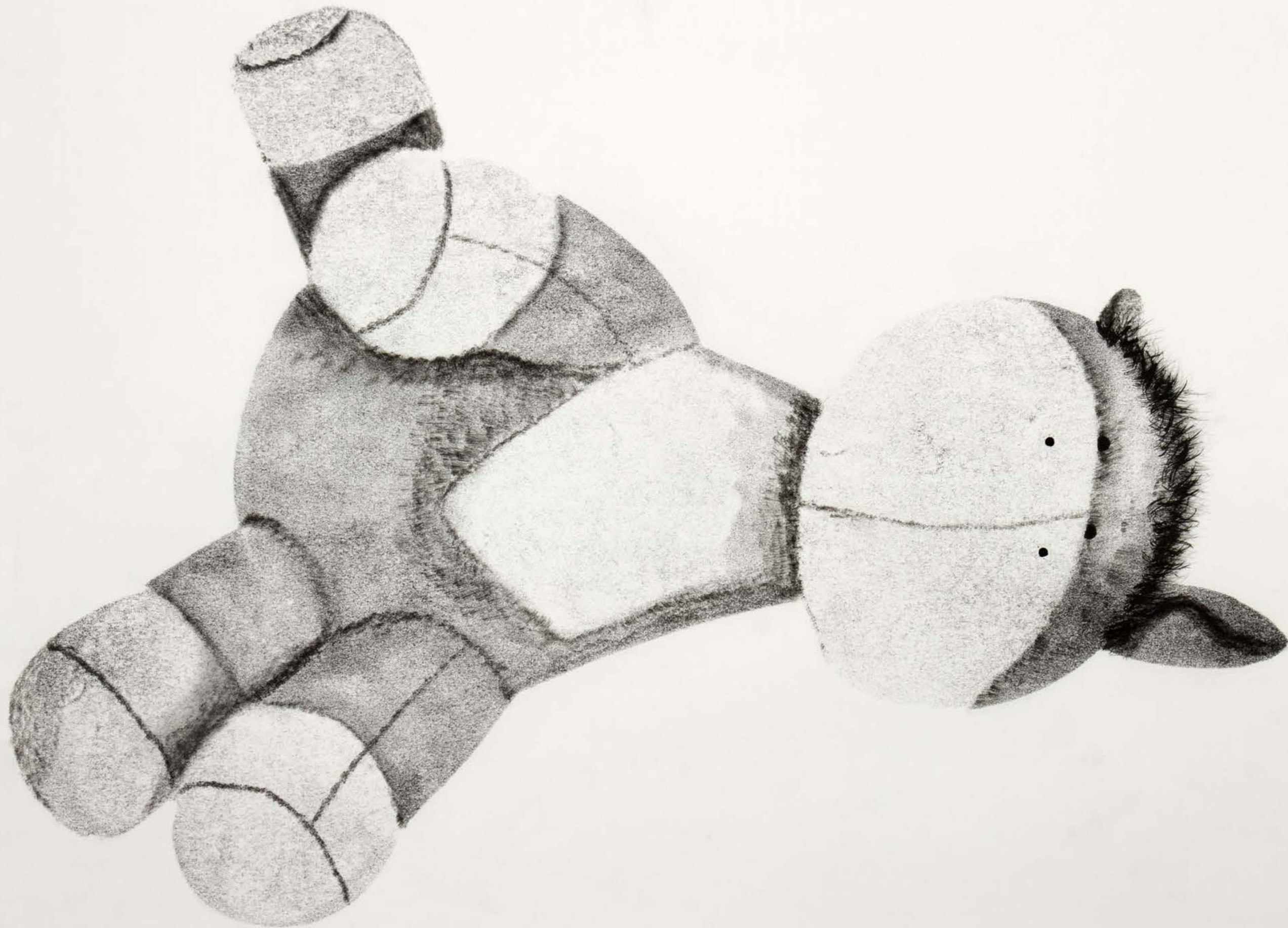

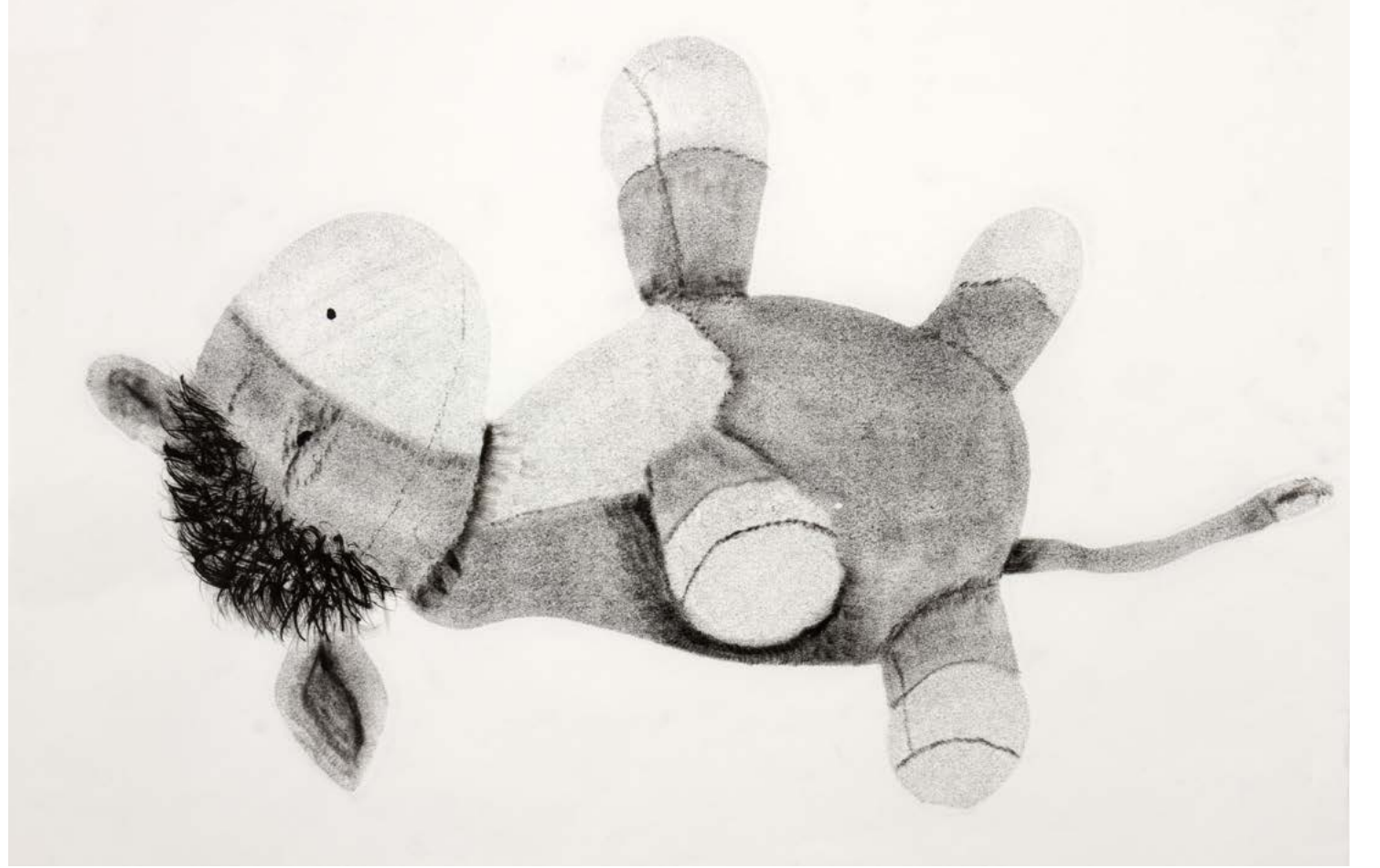
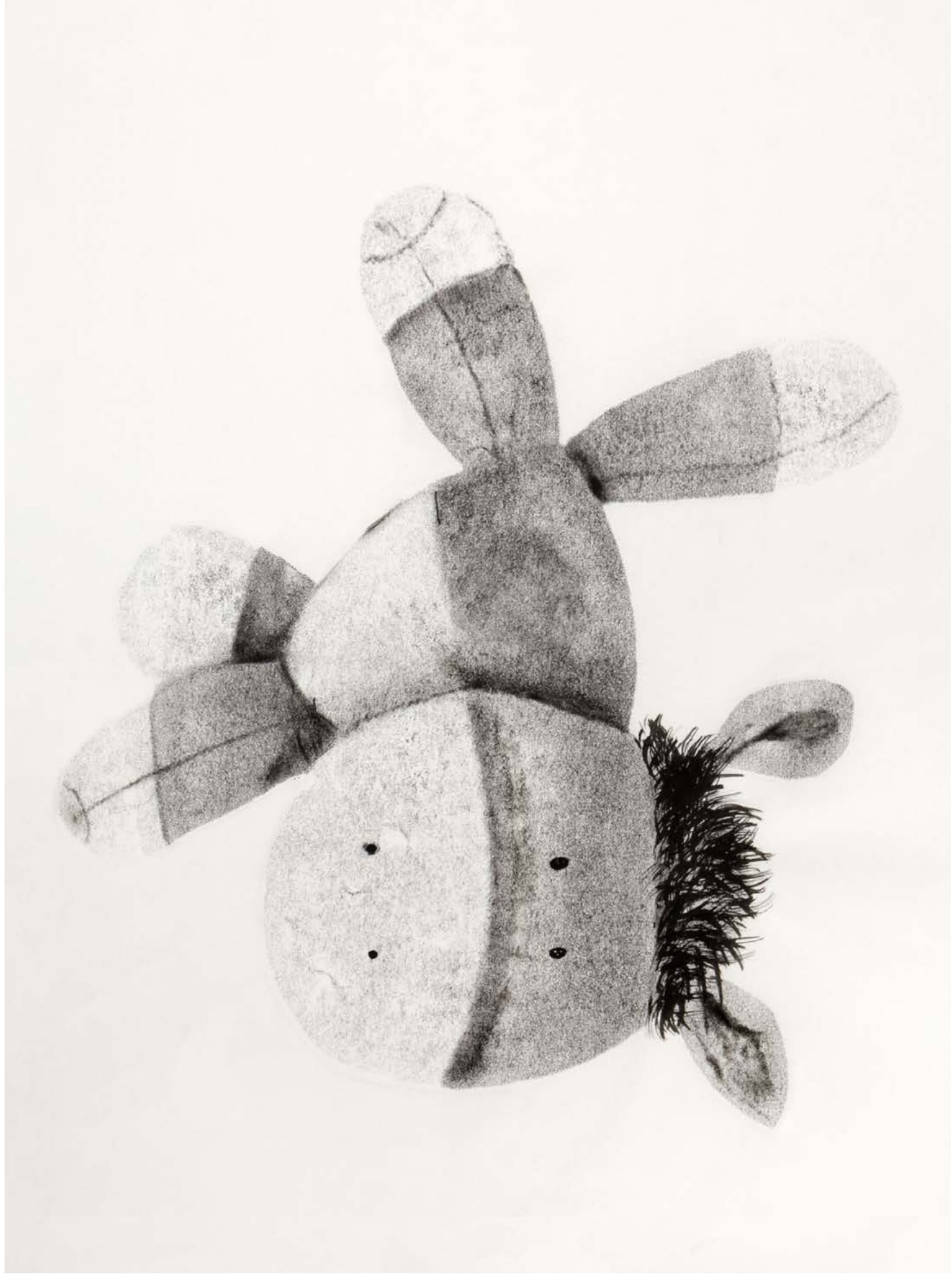



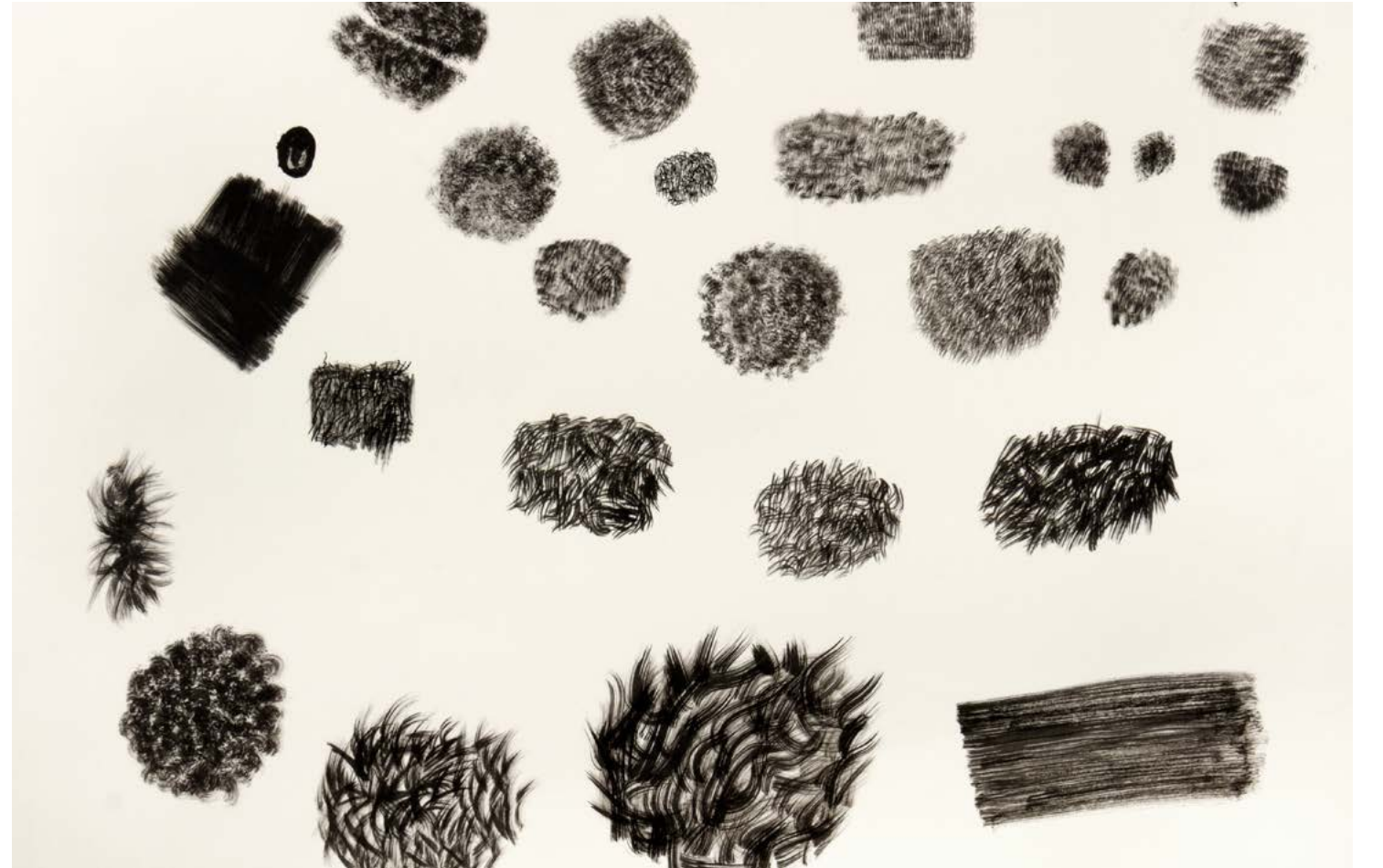
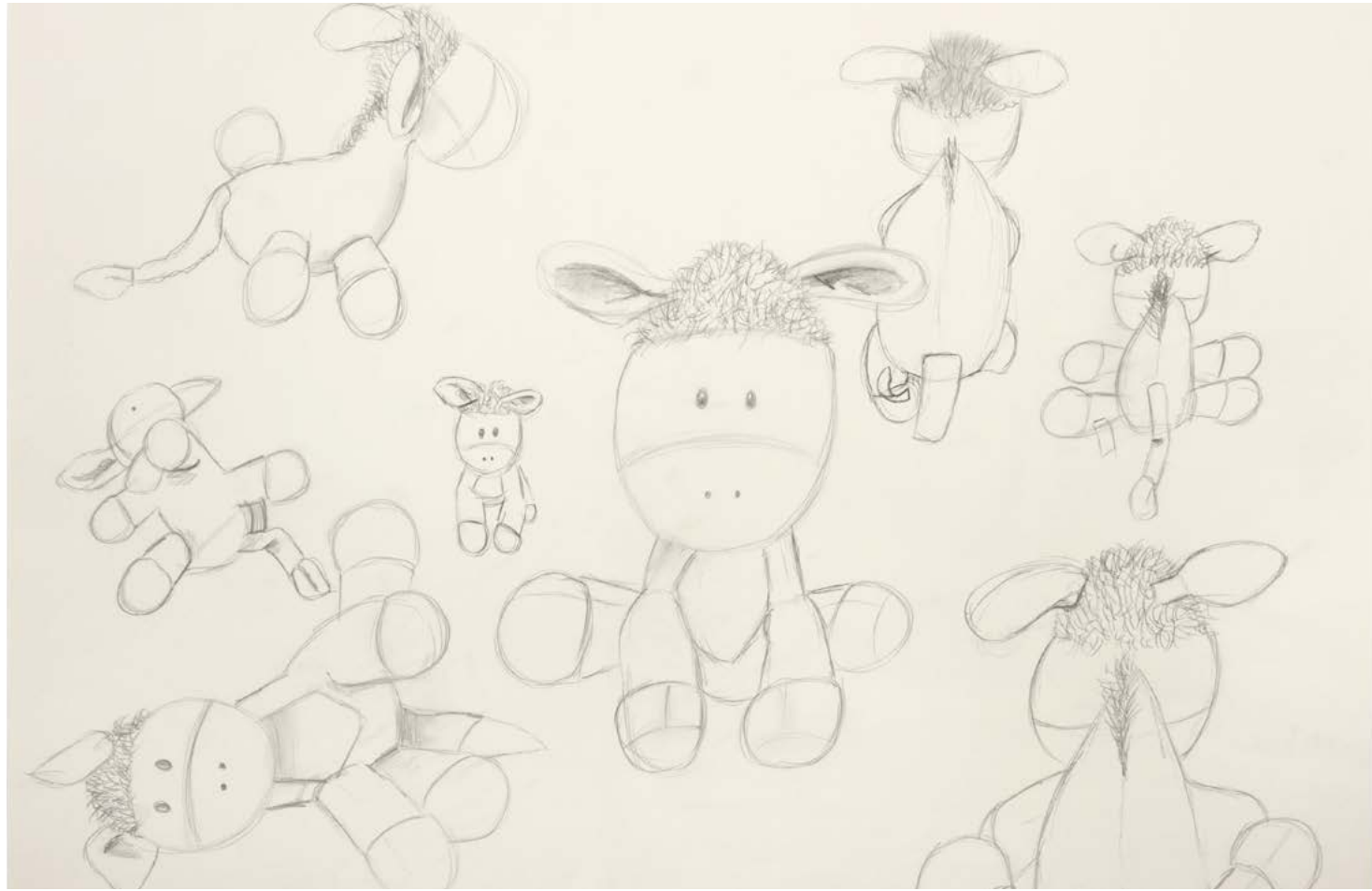



Shelf by Shelf

Layout, Editorial, Zeichnen

August 2021

Unsere Studienreise im 3. Ausbildungsjahr führte uns nach Appenzell in die Bibliothek von Andreas Züst. Dort generierten alle 23 Studierenden während vier Tagen Bild- und Textmaterial. Meine Aufgabe bestand anschliessend darin, dieses Material zusammen mit Konversationen über das Lesen und Bücher im Allgemeinen in einer Publikation zusammenzufügen. Mein Layout setzt sich stark mit dem Raum der Bibliothek auseinander. Dichte und Luftigkeit, wie man sie in der Bibliothek selbst wahrnimmt, verbinden sich in meinem Buch. Geordnet ist das Bild- und Textmaterial nach den verschiedenen Bücherregalen.

16. Пространственные
карты



18



2

17. Географические карты
и планы
составленные по
данным космической
съемки



17

19



20. Фотографии
космоса
созданные
в процессе
полета
космонавтов



20

21



22



22

NI

23



23

25 MKU-23/C clip - in subassembly used to mount heavy large-diameter nuclear weapons in bombers. Support bolts were held together by cables which were cut by an explosive-driven wire cutter, thus releasing the bomb. (USAF)



30 8. Das Rohr, das Tyndall bei seinen Versuchen über die Streuung des Lichtes durch feine, in der Luft schwebende Teilchen benutzte. (S. 96)

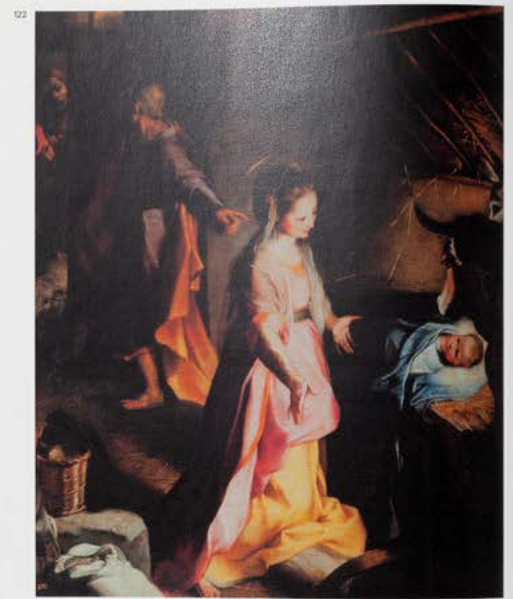
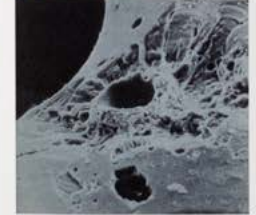

123 285. Portrait de Marcel Duchamp, 1955, aquarelle



206 Scream and water



209 Divina, 1915-204



208 Selbstporträt, 1938. Öl auf Leinwand. Spätschichtweise, wie ein Zeichnergenie. Die röhrlige, Collagen oder Fotografien, sind ein gegenwärtiges Motiv in Blumenfelds Ceuve.



112 Beverly Hills, September 1979: Barbera und Timothy Leary feiern, nachdem der Bezirksanwalt von Los Angeles eine Anklage gegen sie hat fallenlassen, weil eine nächtliche Razzia keine illegale Drogen hervorbrachte.



112

113 Abb. 25 Puck

115 Avebury Trusloe, Wiltshire, 9. Juni 1991. Besucher klagen über Kopfschmerzen und Benommenheit.

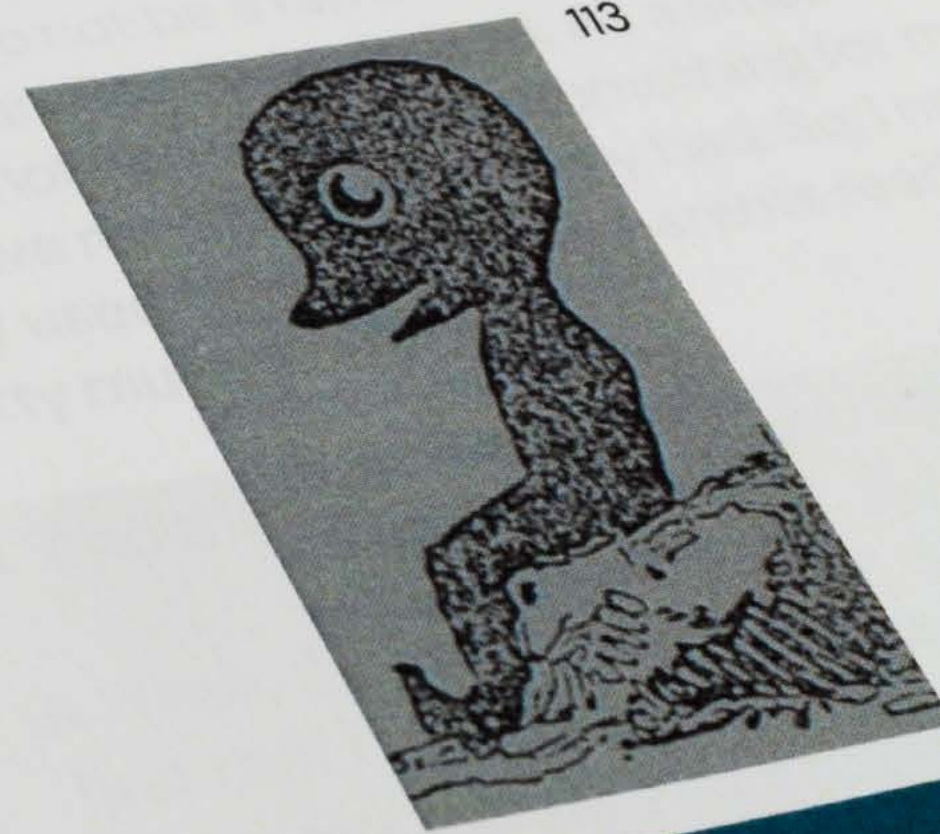

113

114

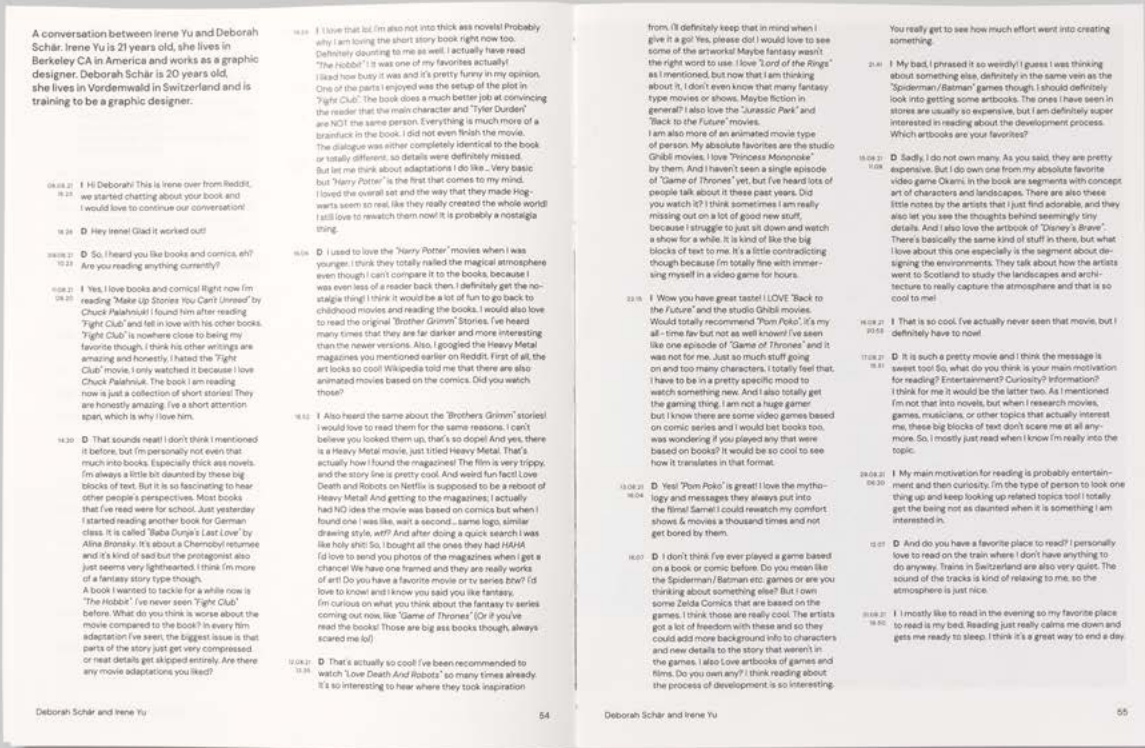

A conversation between Irene Yu and Deborah Schär. Irene Yu is 21 years old, she lives in Berkeley CA in America and works as a graphic designer. Deborah Schär is 20 years old, she lives in Vorderweil in Switzerland and is training to be a graphic designer.

I Hi Deborah! This is Irene over from Reddit, we started chatting about your book and I would love to continue our conversation!

D Hey Irene! Glad it worked out!

I So, I heard you like books and comics, are you reading anything currently?

D Yes, I love books and comics! Right now I'm reading 'Make Up Stories: You Can't Unread' by Chuck Palahniuk. I found him after reading 'Fight Club' and fell in love with his other books. 'Fight Club' is nowhere close to being my favorite though, I think his other writings are amazing and honestly, I hated the 'Fight Club' movie. I only watched it because I love Chuck Palahniuk. The book I am reading now is just a collection of short stories. They are honestly amazing. I've a short attention span, which is why I love them.

I That sounds neat! I don't think I mentioned it before, but I'm personally not even that much into books. Especially trick as novels. I'm always a little bit daunted by these big blocks of text. But it is so fascinating to hear other people's perspectives. Most books that I've read were for school. Just yesterday I started reading another book for German class. It is called 'Sabbat's Last Love' by Alina Bronsky. It's about a Chernobyl survivor and it's kind of sad but the protagonist also just seems very lighthearted. I think I'm more of a fantasy story type though.

A book I wanted to check for a while now is 'The Hobbit'. I've never seen 'Fight Club' before. What do you think is worse about the movie compared to the book? In every film adaptation I've seen, the biggest issue is that parts of the story just get very compressed or neat details get skipped entirely. Are there any movie adaptations you like?

I I love that lol. I'm also not into thick as novels! Probably why I am loving the short story book right now too. (Deliciously daunting to me as well). I actually have read 'The Hobbit'! It was one of my favorites actually! I liked how busy it was and it's pretty funny in my opinion. One of the parts I enjoyed was the setup of the plot in 'Fight Club'. The book does a much better job at convincing the reader that the main character and 'Tyler Durden' are NOT the same person. Everything is much more of a brainfuck in the book. I did not even finish the movie. The dialogue was either completely identical to the book or totally different, so details were definitely missed. But let me think about adaptations I do like... Very basic but 'Harry Potter' is the first that comes to my mind. I loved the overall set and the way that they made Hogwarts seem so real, like they really created the whole world I still love to revisit them now! It is probably a nostalgic thing.

I Used to love the 'Harry Potter' movies when I was younger. I think they totally nailed the magical atmosphere even though I can't compare it to the books, because I was even less of a reader back then. I definitely get the nostalgia thing! I think it would be a lot of fun to go back to childhood movies and reading the books. I would also love to read the original 'Brother Grimm' Stories. I've heard many times that they are far darker and more interesting than the newer versions. Also, I googled the Heavy Metal magazines you mentioned earlier on Reddit. First of all, the art books so cool! Wikipedia told me that there are also animated movies based on the comics. Did you watch those?

I Also heard the same about the 'Brothers Grimm' stories! I would love to read them for the same reasons. I can't believe you looked them up, that's so dope! And yes, there is a Heavy Metal movie, just titled Heavy Metal. That's actually how I found the magazines! The film is very trippy, and the story line is pretty cool. And weird fun fact! Love Death and Robots on Netflix is supposed to be a reboot of Heavy Metal. And getting to the magazines, I actually had NO idea the movie was based on comics but when I found one I was like, wait a second, same logo, similar drawing style, etc! And after doing a quick search I was like holy shit! So, I bought all the ones they had HAHA. I'd love to send you photos of the magazines when I get a chance! I have one I signed and they are really works of art! Do you have a favorite movie or tv series btw? I'd love to know and I know you said you like fantasy.

I'm curious on when you think about the fantasy tv series coming out now, like 'Game of Thrones'. Or if you've read the book! Those are big ass books though, always scared me lol!

D That's actually so cool! I've been recommended to watch 'Love Death and Robots' so many times already. It's so interesting to hear where they took inspiration from. It definitely keeps that in mind when I give it a go! Yes, please do! I would love to see some of the artwork! Maybe fantasy wasn't the right word to use. I love 'Lord of the Rings' as mentioned, but now that I am thinking about it, I don't even know how many fantasy type movies or shows. Maybe fiction in general? I also love the 'Jurassic Park' and 'Back to the Future' movies. I am also more of an animated movie type of person. My absolute favorites are the Studio Ghibli movies. I love 'Princess Mononoke' by them. And I haven't seen a single episode of 'Game of Thrones' yet, but I've heard lots of people talk about it these past years. Did you watch it? I think sometimes I am really missing out on a lot of good new stuff, because I struggle to just sit down and watch a show for a while. It is kind of like the big blocks of text to me. It's a little bit contradicting though because I'm totally into with immersing myself in a video game for hours.

I Now you have great taste! I LOVE 'Back to the Future' and the Studio Ghibli movies. Would totally recommend 'Pun Poku', it's my all-time fav but not as well known! I've seen like one episode of 'Game of Thrones' and it was not for me. Just so much stuff going on and too many characters. I totally feel that. I have to be in a pretty specific mood to watch something new. And also totally get the gaming thing. I am not a 'huge gamer' but I know there are some video games based on comic series and I would bet books too, was wondering if you played any that were based on books? It would be so cool to see how it translates in that format.

I 'Pun Poku' is great! I love the mythology and messages they always put into the final game! I could rewatch my comfort & movies a thousand times and not get bored by them.

I I don't think I've ever played a game based on a book or comic before. Do you mean like the Spiderman/Satman etc. games or are you thinking about something else? But I own some Zentix Comics that are based on the games. I think those are really cool. The artists got a lot of freedom with these and so they could add more background info to characters and new details to the story that wasn't in the games. I also love art books of games and films. Do you own any? I think reading about the process of development is so interesting.

D Well, the first question is what have you read today? What are you currently reading, and what is the last text you have read?

OK well I am currently reading 'Hope Street' from Campino, the lead singer of the Toten Hosen and I'm not a Toten Hosen fan, but it's all about Liverpool Football Club. It's all about Cornwall. I don't know their music. But since I've been here, they're always somewhere. The book is very good. First thing I read this morning was 'The Guardian'. I read the sports section of 'The Guardian'. I also read one of the obituaries from Charlie Watts I took out of the newspapers the other day.

The last thing I read was yesterday, my own text. I read it again to make sure that it was actually pretty good. Or if there was something I wanted to change that bothered me. Book-wise, it was 'We Were Liars' by E. Lockhart. I'm obsessed with that book at the moment. What is the first book you remember reading? And did you read it yourself or was it read to you?

One of the earliest books I can remember, I do not know whether it is the first or not, was 'Treasure Island' by Robert Louis Stevenson. It is a classic of course, and it is as you know a very good book for young people to read. 'Treasure Island', yeah. There's

from, it definitely keeps that in mind when I give it a go! Yes, please do! I would love to see some of the artwork! Maybe fantasy wasn't the right word to use. I love 'Lord of the Rings' as mentioned, but now that I am thinking about it, I don't even know how many fantasy type movies or shows. Maybe fiction in general? I also love the 'Jurassic Park' and 'Back to the Future' movies. I am also more of an animated movie type of person. My absolute favorites are the Studio Ghibli movies. I love 'Princess Mononoke' by them. And I haven't seen a single episode of 'Game of Thrones' yet, but I've heard lots of people talk about it these past years. Did you watch it? I think sometimes I am really missing out on a lot of good new stuff, because I struggle to just sit down and watch a show for a while. It is kind of like the big blocks of text to me. It's a little bit contradicting though because I'm totally into with immersing myself in a video game for hours.

I Now you have great taste! I LOVE 'Back to the Future' and the Studio Ghibli movies. Would totally recommend 'Pun Poku', it's my all-time fav but not as well known! I've seen like one episode of 'Game of Thrones' and it was not for me. Just so much stuff going on and too many characters. I totally feel that. I have to be in a pretty specific mood to watch something new. And also totally get the gaming thing. I am not a 'huge gamer' but I know there are some video games based on comic series and I would bet books too, was wondering if you played any that were based on books? It would be so cool to see how it translates in that format.

I 'Pun Poku' is great! I love the mythology and messages they always put into the final game! I could rewatch my comfort & movies a thousand times and not get bored by them.

I I don't think I've ever played a game based on a book or comic before. Do you mean like the Spiderman/Satman etc. games or are you thinking about something else? But I own some Zentix Comics that are based on the games. I think those are really cool. The artists got a lot of freedom with these and so they could add more background info to characters and new details to the story that wasn't in the games. I also love art books of games and films. Do you own any? I think reading about the process of development is so interesting.

D Well, the first question is what have you read today? What are you currently reading, and what is the last text you have read?

OK well I am currently reading 'Hope Street' from Campino, the lead singer of the Toten Hosen and I'm not a Toten Hosen fan, but it's all about Liverpool Football Club. It's all about Cornwall. I don't know their music. But since I've been here, they're always somewhere. The book is very good. First thing I read this morning was 'The Guardian'. I read the sports section of 'The Guardian'. I also read one of the obituaries from Charlie Watts I took out of the newspapers the other day.

The last thing I read was yesterday, my own text. I read it again to make sure that it was actually pretty good. Or if there was something I wanted to change that bothered me. Book-wise, it was 'We Were Liars' by E. Lockhart. I'm obsessed with that book at the moment. What is the first book you remember reading? And did you read it yourself or was it read to you?

One of the earliest books I can remember, I do not know whether it is the first or not, was 'Treasure Island' by Robert Louis Stevenson. It is a classic of course, and it is as you know a very good book for young people to read. 'Treasure Island', yeah. There's

you really get to see how much effort went into creating something.

I My best, I phrased it so weirdly! I guess I was thinking about something else, definitely in the same vein as the 'Spiderman/Satman' games though. I should definitely look into getting some artbooks. The ones I have seen in stores are usually so expensive, but I am definitely super interested in reading about the development process. Which artbooks are your favorites?

D Sadly, I do not own many. As you said, they are pretty expensive. But I do own one from my absolute favorite video game, Okami. In the book are segments with concept art of characters and landscapes. There are also these little notes by the artists that I just find adorable, and they also let you see the thoughts behind seemingly tiny details. And I also love the artbook of 'Disney's Dream'. There's basically the same kind of stuff in there, but what I love about this one especially is the segment about designing the environments. They talk about how the artists went to Scotland to study the landscapes and architecture to really capture the atmosphere and that is so cool to me!

I That is so cool, I've actually never seen that movie, but I definitely have to not!

D It is such a pretty movie and I think the message is sweet too! So, what do you think is your main motivation for reading? Entertainment? Curiosity? Information? I think for me it would be the latter two. As I mentioned I'm not that into novels, but when I research movies, games, musicians, or other topics that actually interest me, these big blocks of text don't scare me at all anymore. So, I mostly just read when I know I'm really into the topic.

I My main motivation for reading is probably entertainment and then curiosity. I'm the type of person to look one thing up and keep looking up related topics too! I totally get the being so daunted when it is something I am interested in.

D And do you have a favorite place to read? I personally love to read on the train when I don't have anything to do anymore. Trains in Switzerland are also very quiet. The sound of the tracks is kind of relaxing to me, so the atmosphere is just nice.

I I mostly like to read in the evening so my favorite place to read is my bed. Reading just really carries me down and gets me ready to sleep. I think it's a great way to end a day

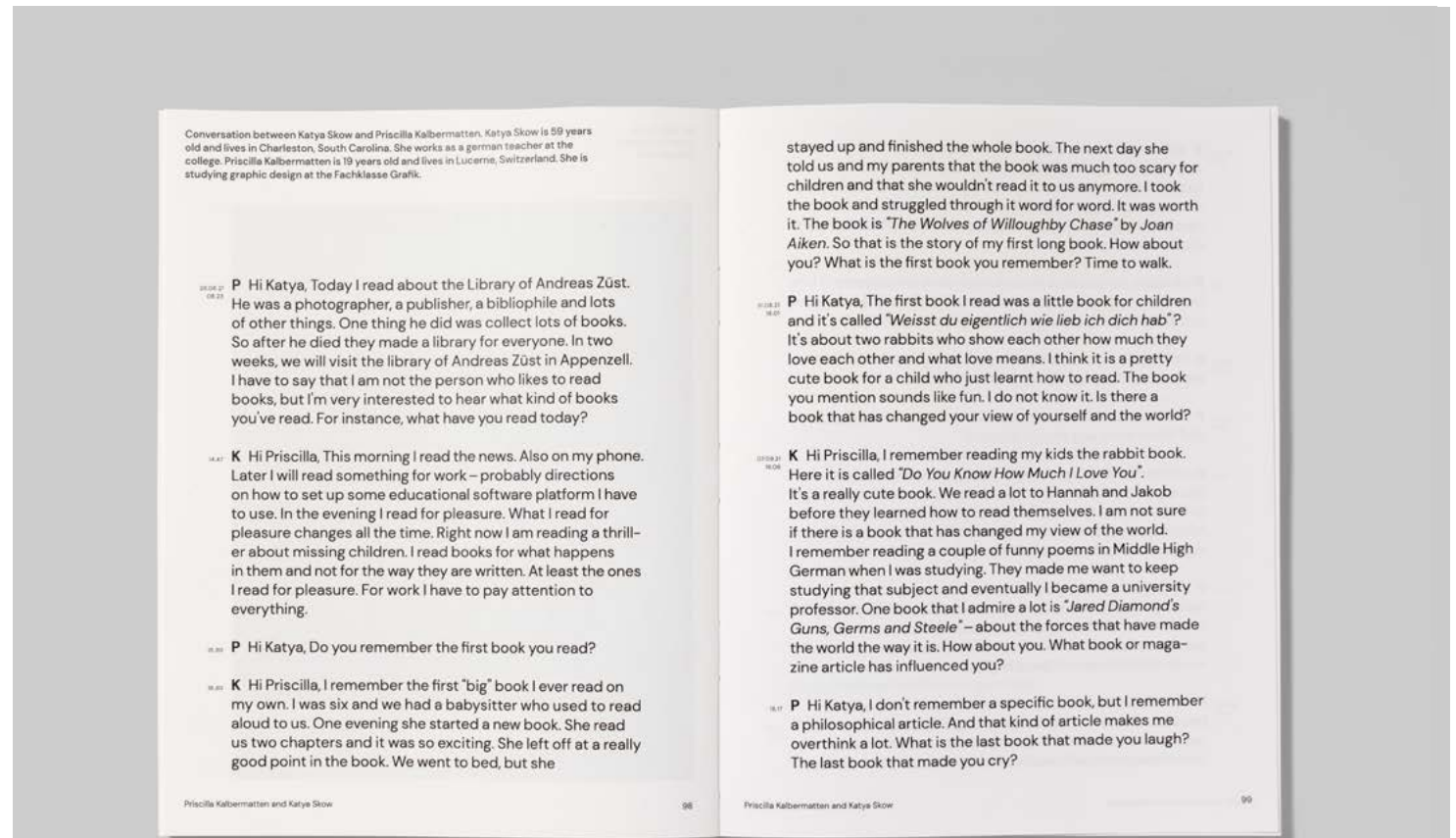

Conversation between Katya Skow and Priscilla Kalbermatten. Katya Skow is 59 years old and lives in Charleston, South Carolina. She works as a German teacher at the college. Priscilla Kalbermatten is 19 years old and lives in Lucerne, Switzerland. She is studying graphic design at the Fachklasse Grafik.

Hi Katya, Today I read about the Library of Andreas Züst. He was a photographer, a publisher, a bibliophile and lots of other things. One thing he did was collect lots of books. So after he died they made a library for everyone. In two weeks, we will visit the library of Andreas Züst in Appenzell. I have to say that I am not the person who likes to read books, but I'm very interested to hear what kind of books you've read. For instance, what have you read today?

Hi Priscilla, This morning I read the news. Also on my phone. Later I will read something for work - probably directions on how to set up some educational software platform I have to use. In the evening I read for pleasure. What I read for pleasure changes all the time. Right now I am reading a thriller about missing children. I read books for what happens in them and not for the way they are written. At least the ones I read for pleasure. For work I have to pay attention to everything.

Do you remember the first book you read?

Hi Priscilla, I remember the first "big" book I ever read on my own. I was six and we had a babysitter who used to read aloud to us. One evening she started a new book. She read us two chapters and it was so exciting. She left off at a really good point in the book. We went to bed, but she

stayed up and finished the whole book. The next day she told us and my parents that the book was much too scary for children and that she wouldn't read it to us anymore. I took the book and struggled through it word for word. It was worth it. The book is 'The Wolves of Willoughby Chase' by Joan Aiken. So that is the story of my first long book. How about you? What is the first book you remember? Time to walk.

The first book I read was a little book for children and it's called 'Weisst du eigentlich wie lieb ich dich hab'? It's about two rabbits who show each other how much they love each other and what love means. I think it is a pretty cute book for a child who just learnt how to read. The book you mention sounds like fun. I do not know it. Is there a book that has changed your view of yourself and the world?

Hi Priscilla, I remember reading my kids the rabbit book. Here it is called 'Do You Know How Much I Love You'. It's a really cute book. We read a lot to Hannah and Jakob before they learned how to read themselves. I am not sure if there is a book that has changed my view of the world. I remember reading a couple of funny poems in Middle High German when I was studying. They made me want to keep studying that subject and eventually I became a university professor. One book that I admire a lot is 'Jared Diamond's Guns, Germs and Steele' - about the forces that have made the world the way it is. How about you. What book or magazine article has influenced you?

I don't remember a specific book, but I remember a philosophical article. And that kind of article makes me overthink a lot. What is the last book that made you laugh? The last book that made you cry?

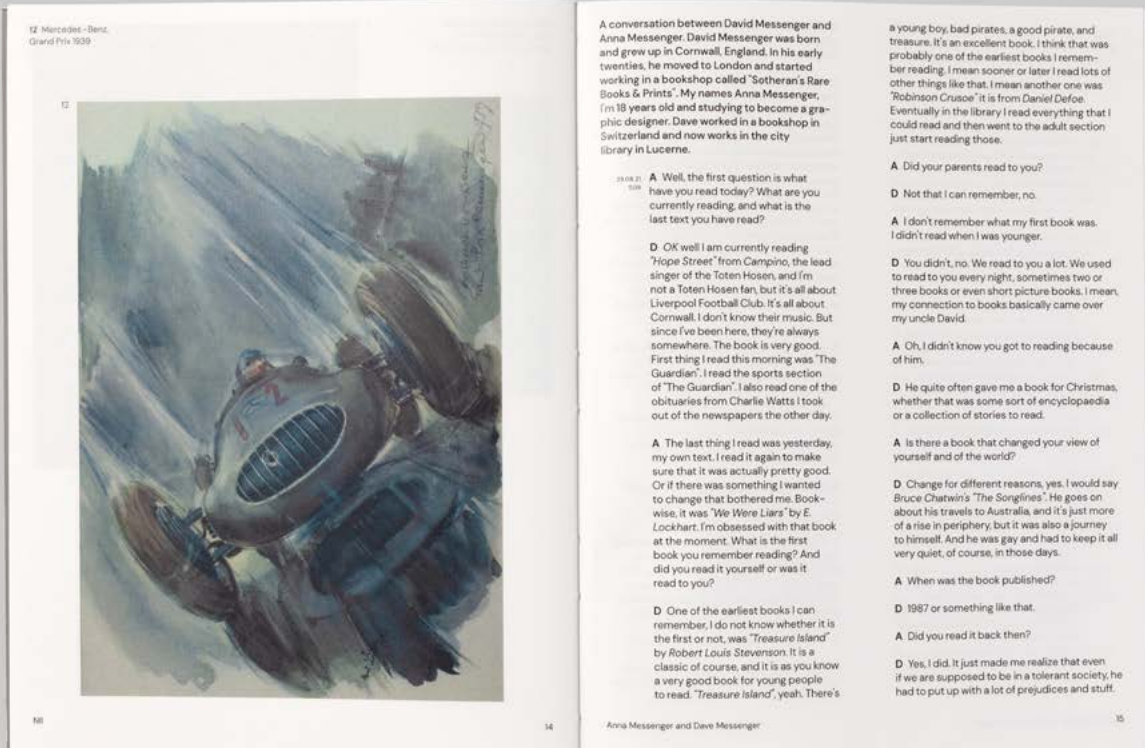

Mercedes-Benz Grand Prix 1939



A conversation between David Messenger and Anna Messenger. David Messenger was born and grew up in Cornwall, England. In his early twenties, he moved to London and started working in a bookshop called 'Sotheran's Rare Books & Prints'. My names Anna Messenger, I'm 19 years old and studying to become a graphic designer. Dave worked in a bookshop in Switzerland and now works in the city library in Lucerne.

Well, the first question is what have you read today? What are you currently reading, and what is the last text you have read?

OK well I am currently reading 'Hope Street' from Campino, the lead singer of the Toten Hosen and I'm not a Toten Hosen fan, but it's all about Liverpool Football Club. It's all about Cornwall. I don't know their music. But since I've been here, they're always somewhere. The book is very good. First thing I read this morning was 'The Guardian'. I read the sports section of 'The Guardian'. I also read one of the obituaries from Charlie Watts I took out of the newspapers the other day.

The last thing I read was yesterday, my own text. I read it again to make sure that it was actually pretty good. Or if there was something I wanted to change that bothered me. Book-wise, it was 'We Were Liars' by E. Lockhart. I'm obsessed with that book at the moment. What is the first book you remember reading? And did you read it yourself or was it read to you?

One of the earliest books I can remember, I do not know whether it is the first or not, was 'Treasure Island' by Robert Louis Stevenson. It is a classic of course, and it is as you know a very good book for young people to read. 'Treasure Island', yeah. There's

a young boy, bad pirates, a good pirate, and treasure. It's an excellent book. I think that was probably one of the earliest books I remember reading. I mean sooner or later I read lots of other things like that. I mean another one was 'Robinson Crusoe' it is from Daniel Defoe. Eventually in the library I read everything that I could read and then went to the adult section just start reading those.

Did your parents read to you?

Not that I can remember, no.

I don't remember what my first book was. I didn't read when I was younger.

You didn't, no. We read to you a lot. We used to read to you every night, sometimes two or three books or even short picture books. I mean, my connection to books basically came over my uncle David.

Oh, I didn't know you got to reading because of him.

He quite often gave me a book for Christmas, whether that was some sort of encyclopaedia or a collection of stories to read.

Is there a book that changed your view of yourself and of the world?

Change for different reasons, yes. I would say Bruce Chatwin's 'The Songlines'. He goes on about his travels to Australia, and it's just more of a rise in periphery, but it was also a journey to himself. And he was gay and had to keep it all very quiet, of course, in those days.

When was the book published?

1987 or something like that.

Did you read it back then?

Yes, I did. It just made me realize that even if we are supposed to be in a tolerant society, he had to put up with a lot of prejudices and stuff.

Anna Messenger and Dave Messenger

18

14

15

"Potter" movies when I was
nailed the magical atmosphere
it to the books, because I
ck then. I definitely get the no-
be a lot of fun to go back to
ng the books. I would also love
Grimm" Stories. I've heard
darker and more interesting
I googled the Heavy Metal
earlier on Reddit. First of all, the
old me that there are also
e comics. Did you watch

he "Brothers Grimm" stories!
he same reasons. I can't
at's so dope! And yes, there
ed Heavy Metal. That's
nes! The film is very trippy,
And weird fun fact! Love
upposed to be a reboot of
magazines; I actually
ed on comics but when I
nd... same logo, similar
ing a quick search I was
ones they had HAHA
magazines when I get a
they are really works
ie or tv series btw? I'd
you like fantasy,
ut the fantasy tv series
nes" (Or if you've

a show for a while. It is kind of like the big
blocks of text to me. It's a little contradicting
though because I'm totally fine with immer-
sing myself in a video game for hours.

22.15 I Wow you have great taste! I LOVE "Back to
the Future" and the studio Ghibli movies.
Would totally recommend "Pom Poko", it's my
all-time fav but not as well known! I've seen
like one episode of "Game of Thrones" and it
was not for me. Just so much stuff going
on and too many characters. I totally feel that.
I have to be in a pretty specific mood to
watch something new. And I also totally get
the gaming thing. I am not a huge gamer
but I know there are some video games based
on comic series and I would bet books too,
was wondering if you played any that were
based on books? It would be so cool to see
how it translates in that format.

13.08.21 D Yes! "Pom Poko" is great! I love the mytho-
16.04 logy and messages they always put into
the films! Same! I could rewatch my comfort
shows & movies a thousand times and not
get bored by them.

16.07 D I don't think I've ever played a game based
on a book or comic before. Do you mean like
the Spiderman / Batman etc. games or are you
thinking about something else? But I own
some Zelda Comics that are based on the
games. I think those are really cool. The artists

There's basically the same
I love about this one espe-
signing the environment
went to Scotland to stu-
ecture to really captu-
cool to me!

16.08.21 I That is so cool. I've
20.53 definitely have to n

17.08.21 D It is such a pret
15.51 sweet tool So, wh
for reading? Ent
I think for me it
I'm not that int
games, music
me, these bi
more. So, I n
topic.

29.08.21 I My mai
06.20 ment an
thing up
get the
intere

12.07 D A
lov
do
s
a

31.08.21
18.50



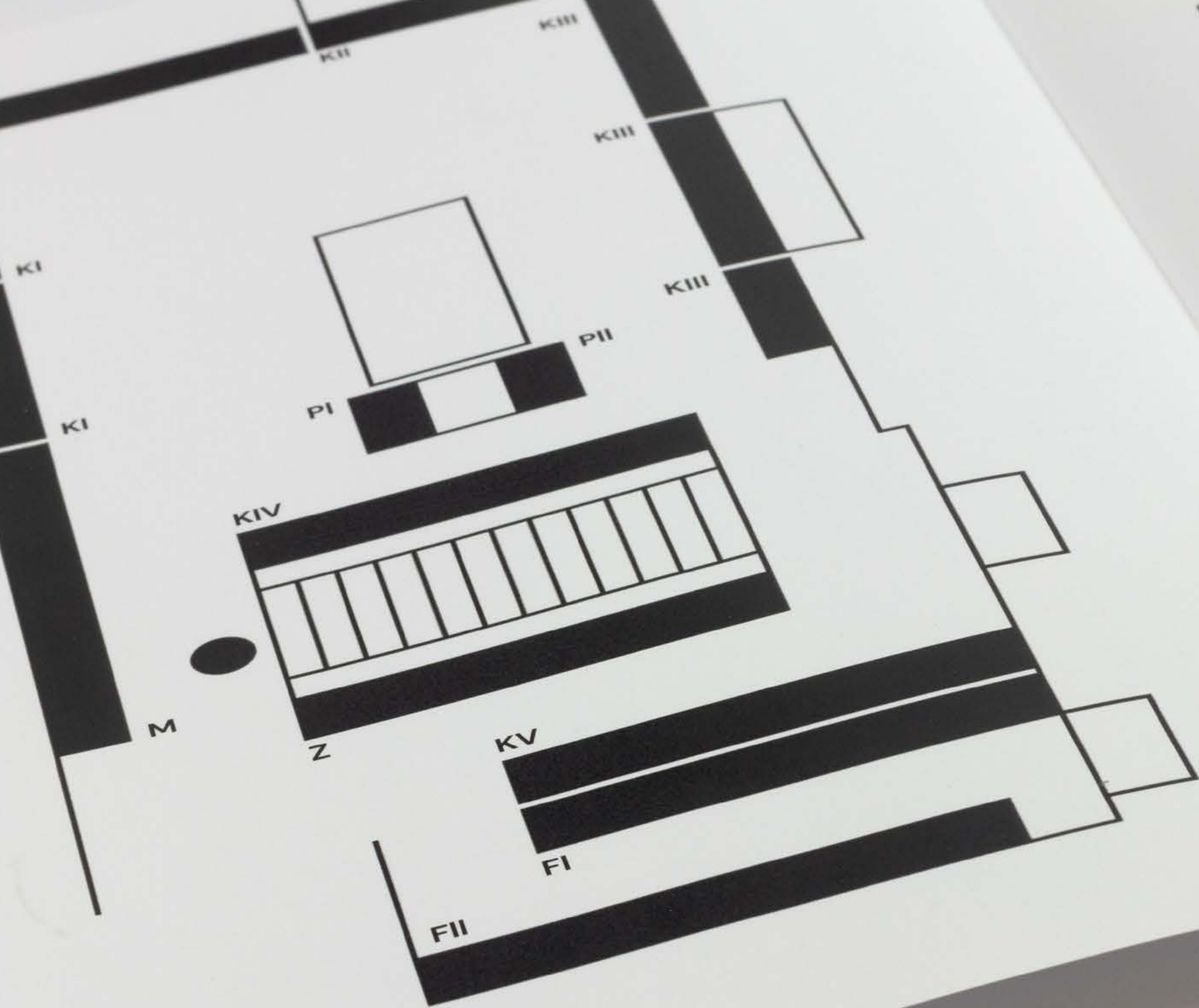

PI	Kunst II	Charlotte
KI	Kunst III	Valerie Bühler
KII	Philosophie II	Arno Röhlin
KIII	Kunst KIV	Noah Suparna
PII	Zeitschriften	Julia Hegi
KIV	Kunst V	Chiara Huber
Z	Fotografie I	Sophie Vogel
KV	Fotografie II	Akira Yamaguchi
FI		Elia Boccia

Index second floor
 Imprint

table of contents

Index second floor



Literatur I



1 Okay Mutter, ich nehme die Mittagsmaschine
Beste Kolumnen
Max Goldt
Haffmans, 1999
LABA G010
3-251-00440-9

Naturwissenschaften II



2 Kunstformen der Natur
Erich Haeckel
Prestel, 1998
NG 013
96298



3 International Cloud Atlas
Volume II
World Meteorological
Organization
Geneva World Meteorological
Organization, 1987
NDA 046
1288505



4 Feuerberge
Hahn Otto
Herder, 1987
NFC 002
3-451-21001-0



5 Eiszeitalter 2
Die jüngste Erdgeschichte
der Schweiz und ihrer
Nachbargebiete
Hantke René
Ott, 1980
NFF 015
3-7225-6259-7



6 Vulkanausbruch
Ursachen und Risiken
Münchner Rückversicherung, 1983
NFC 012



7 Fullerene: Die Buckyballs
erobern die Chemie
Joachim Dettmann
Birkhäuser, 1994
NC 001
1287938



8 Feuerberge
Otto Hahn
Herder, 1987
NFC 002
3-451-21001-0



9 Kein Platz für wilde Tiere
Bernhard Grzimek
Schweizer Druck- und
Verlagshaus, 1954
NHC 014



10 Lexikon der Mykologie
Dörfelt Heinrich
Fischer, 1989
NHB 003
3437204130



11 Vom Wetteraberglauben
zur Wetterforschung
Hans-Günther Körber
Edition Leipzig, 1987
NDA 001



12 Liska Hans
Daimler-Benz Aktiengesellschaft,
Stuttgard - Untertürkheim
Cantz, 1951
NJI 014
1301744



13 THE SHELL
Five Hundred Million Years
of Inspired Design
Hugh und Marguerite Stix and
R. Tucker Abbott
Abrahms, 2000
NFD 018
1292222



14 Wiesenblumenfiabel
Amstutz, Walter (Hrsg.)
Bruckmann, 1943
NHA 007



15 Mit Raketenkraft ins Weltall
vom Feuerwagen zum Raumschiff
Gail Otto Willi
Thienemanns, 1928
NJFF 021

Naturwissenschaften I



16 Vulkanismus
Naturgewalt, Klimafaktor und
kosmische Formkraft
Hans Pichler
Spektrum der Wissenschaft, 1985
NFC 016
3-922508-32-4



17 Fotoatlas der Planeten
Das neue Bild des Sonnensystems
Geoffrey Briggs, Fredric Taylor
Kosmos Verlag, 1982
NAHD A003
3-440-05306-7



18 Catalogue of the Universe
Paul Murdin and David Allen
Cambridge University Press, 1979
NAHE 046
0-521-22859-X



19 Le Ciel
Notins élémentaires
Amédée Guillmein
Librairie Hachette, 1877
NAHA 009



20 Huber Chiara 10
Die Sonne
Das Gestirn in der Kultur-
geschichte
Masanjeet Singh
Wasmuth, 1993
NAHD C012
38030-3059-5



21 Die neue Astronomie
Nigel Henbest, Michael Marten
Birkhäuser Verlag, 1984
NAHC 051

3-7643-1616-0



22 Der neu entdeckte Himmel
Das astronomische Weltbild
gemäss jüngster Forschung
Robert Henseling
Atlantis Verlag, 1930
NAHD A006



23 In die Tiefen des Weltalls
Jefremow, Ju. N.
Thun, 1990
NAHC 009
3-8171-1153-3



24 Erdsicht
Global Change
Diverse Autoren
Gerd Hatje, 1992
NAHD D013



25 US Nuclear Weapons
the Secret History
Chuck Hansen
Aerofax, 1988
NAG 024
0-517-56740-7



Farbstudium

Farbe

Mai 2021

Als Grafikerin werde ich tagtäglich mit Farbe konfrontiert. Farbe ist heutzutage allgegenwärtig, aber wie entsteht diese überhaupt? In diesem Projekt lernte ich, wie man aus verschiedenen Pigmenten und Bindemitteln eigene Aquarell- und Guoachefarben herstellt. Ich experimentierte mit den verschiedenen Möglichkeiten des Farbauftrages und der Farbmischung. Zudem untersuchte ich das Verhalten der Farbe beim Hinzufügen von Flüssigkeiten, wie beispielsweise Essig. Auf diese Weise entstanden überraschende und faszinierende Ergebnisse.

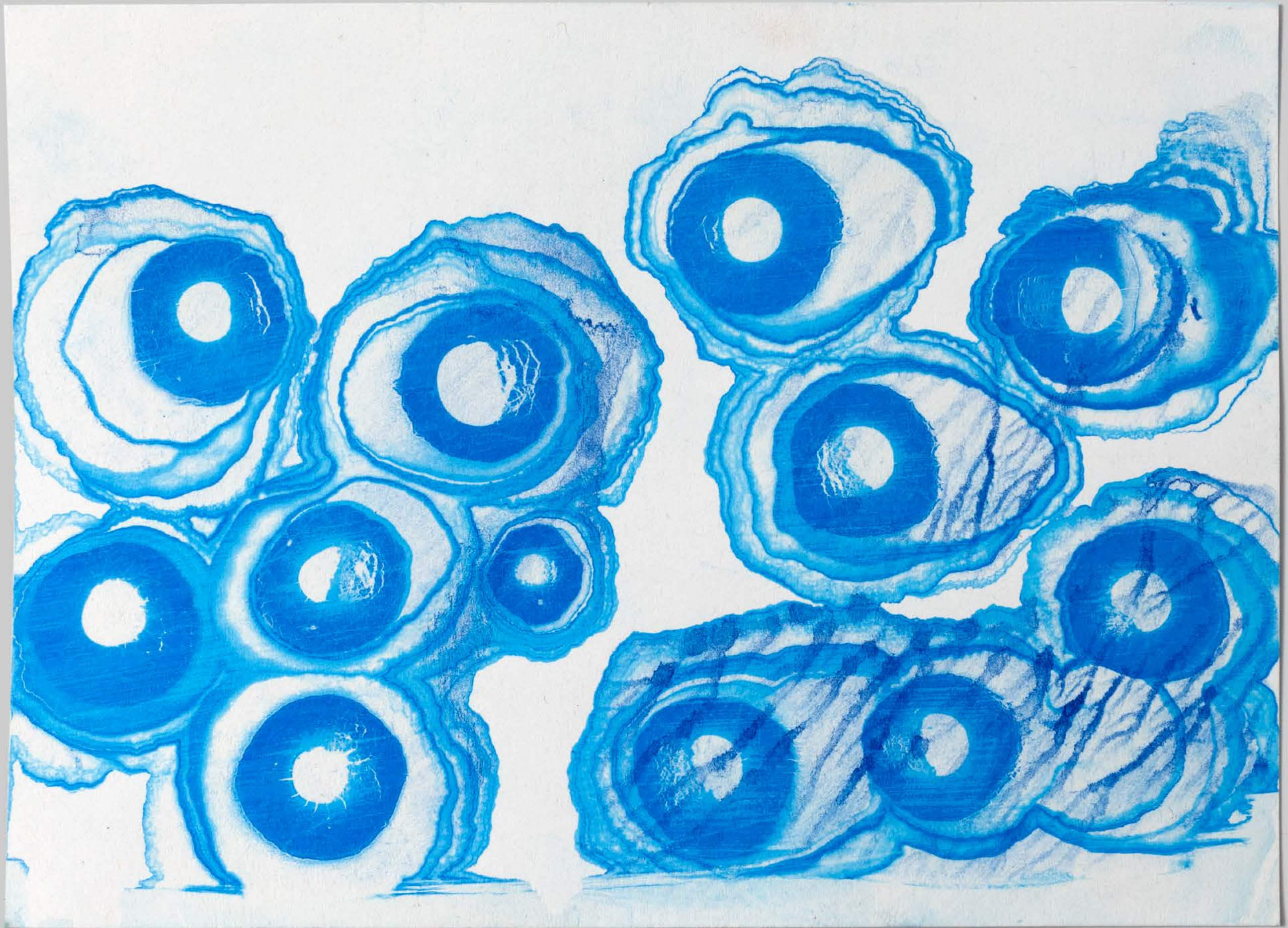

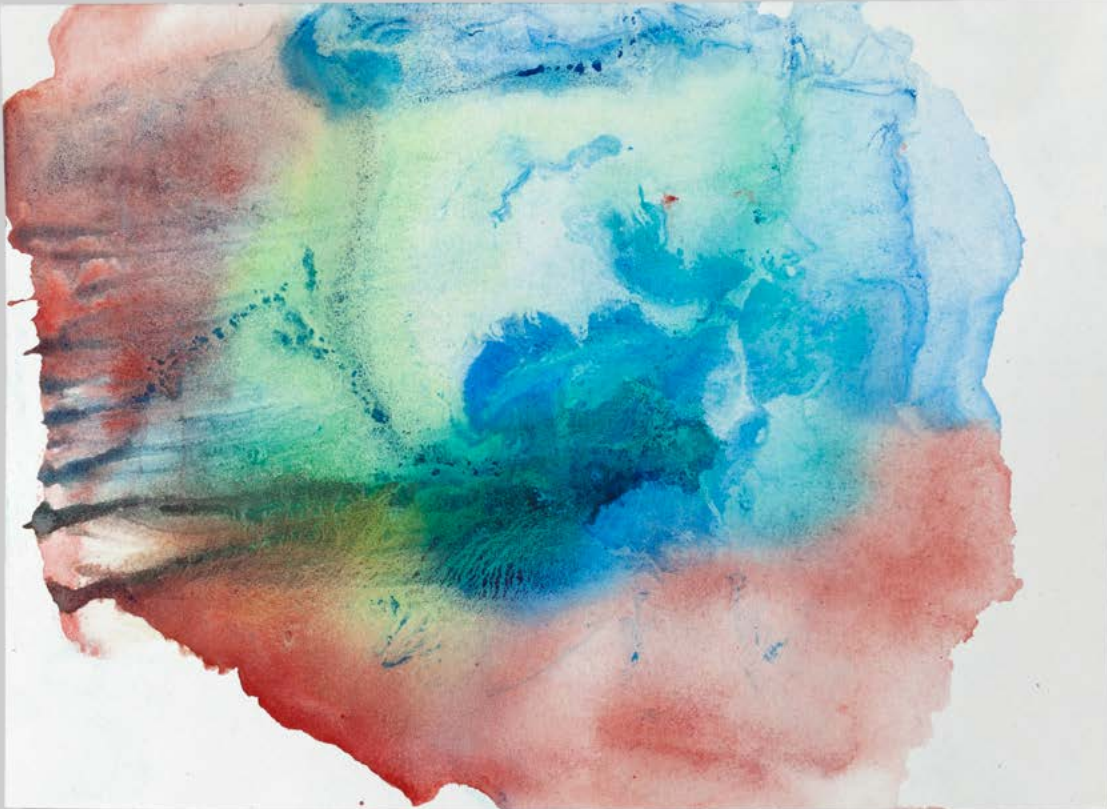

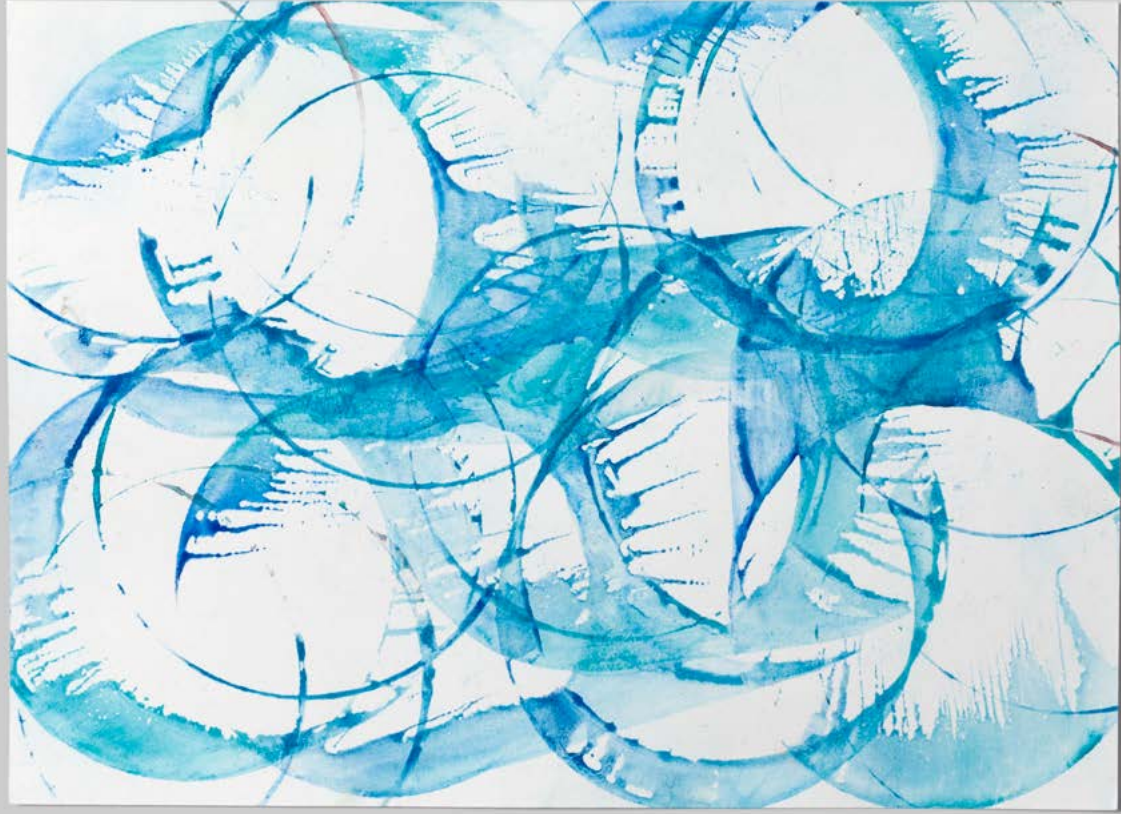

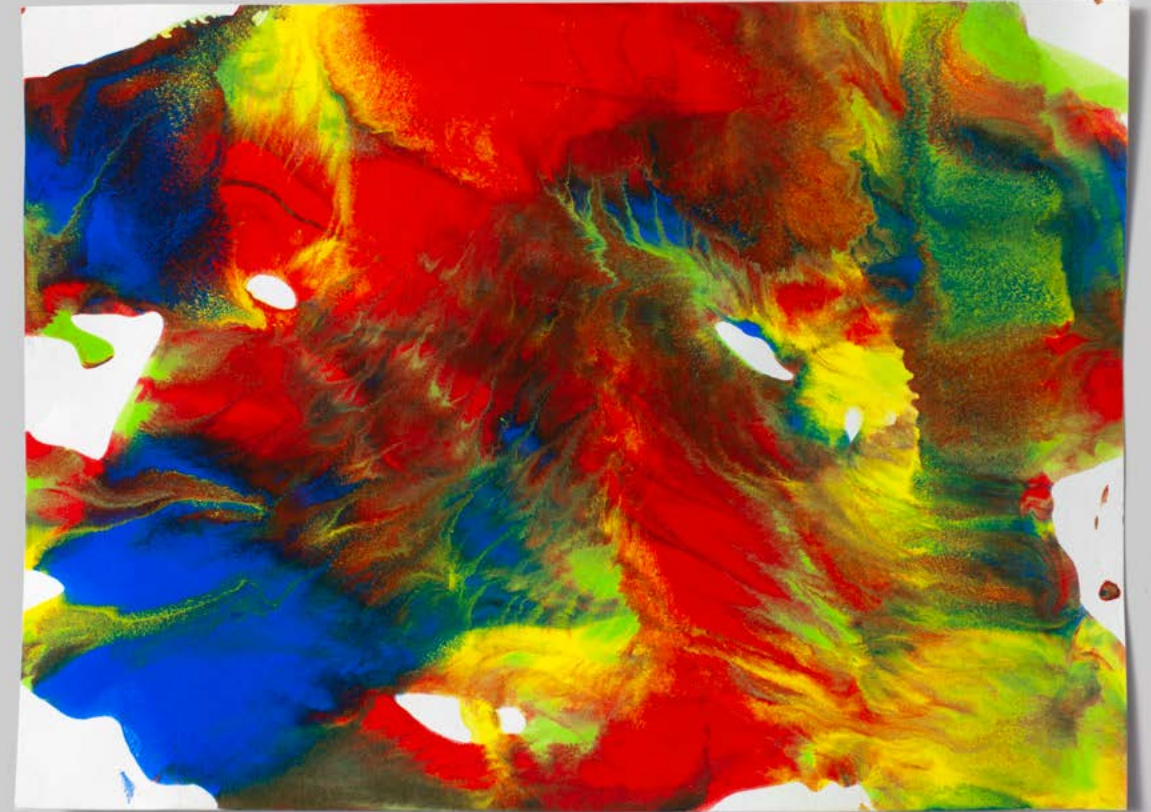

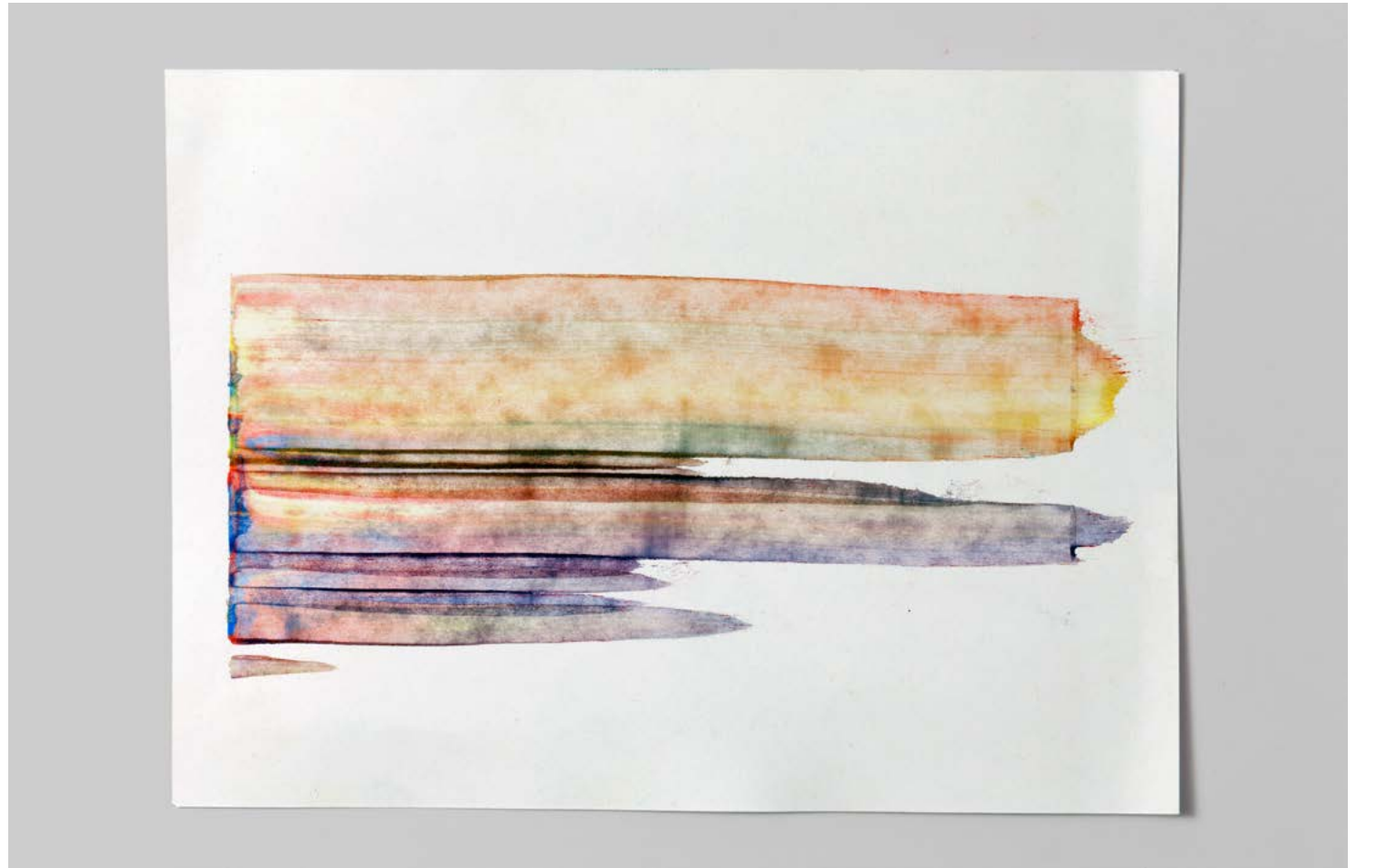



Masterabschlusskonzerte

Typografie, Illustration

März 2021

Hochschule Luzern – Musik

Im Auftrag der Hochschule Luzern – Musik konnte ich ein Plakat für die Masterabschlusskonzerte der Master - Absolventinnen und Absolventen gestalten. Ich beschäftigte mich mit dem Thema der Synästhesie. Welche Formen und Farben nehmen wir beim Hören von Musik wahr? Was löst Musik in uns aus? Wie macht man Rhythmus und Klang sichtbar? Ich experimentierte mit aus Papier ausgeschnittenen Formen, welche ich mittels analoger Technik über dem Scanner verzog. Die daraus entstandenen farbigen, organischen Linien und Formen kombinierte ich mit statischer Typografie und gestaltete so zwei Versionen des Plakates.

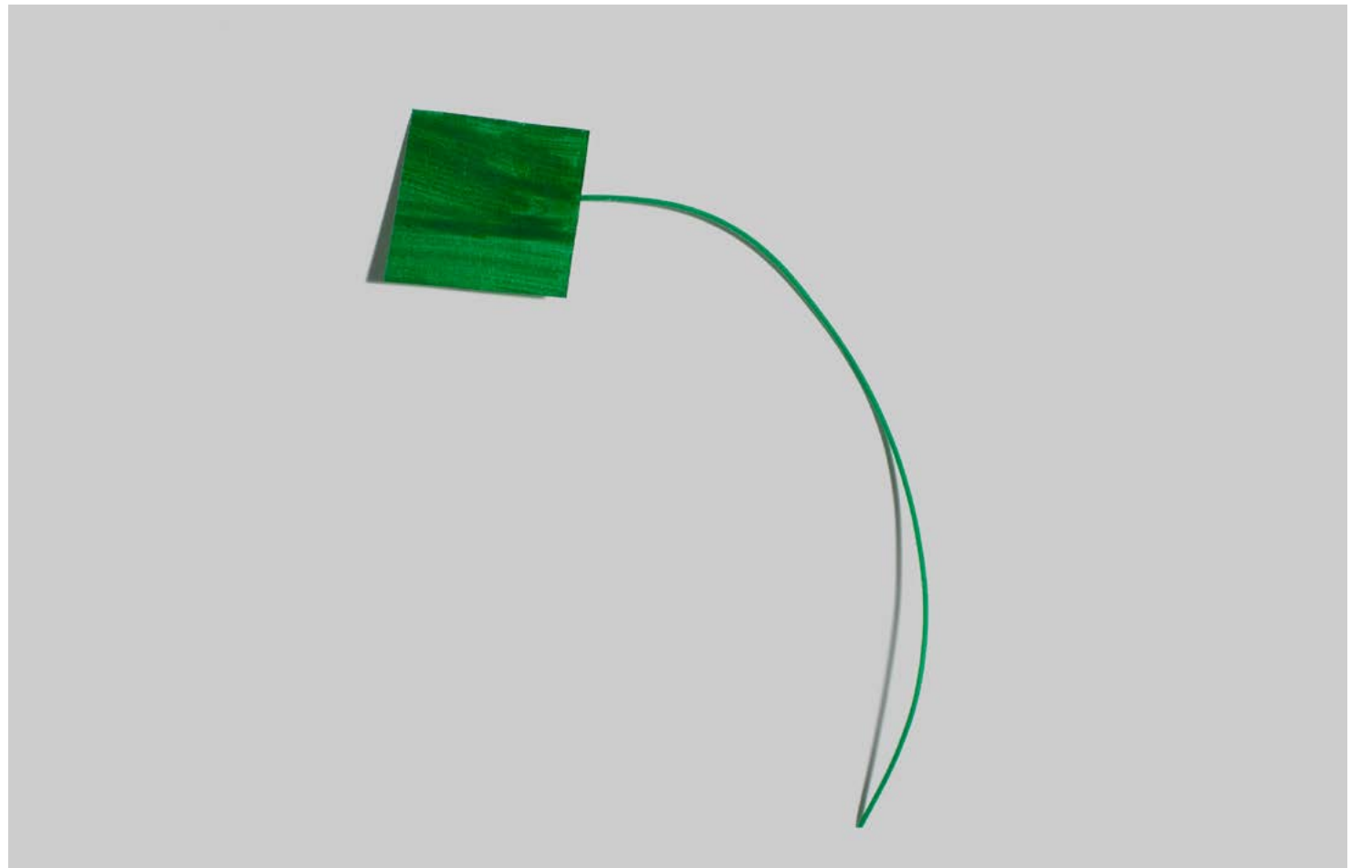
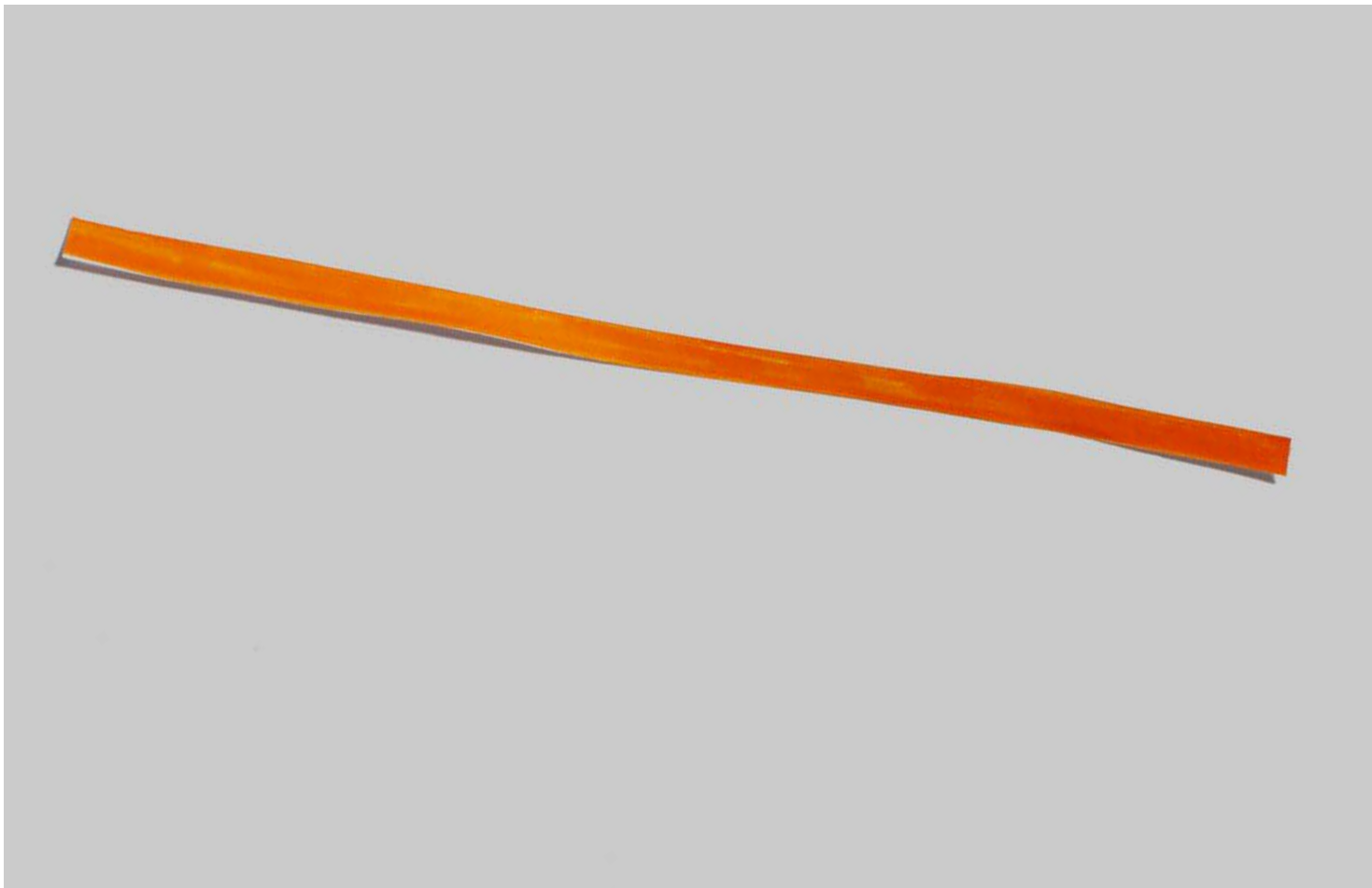
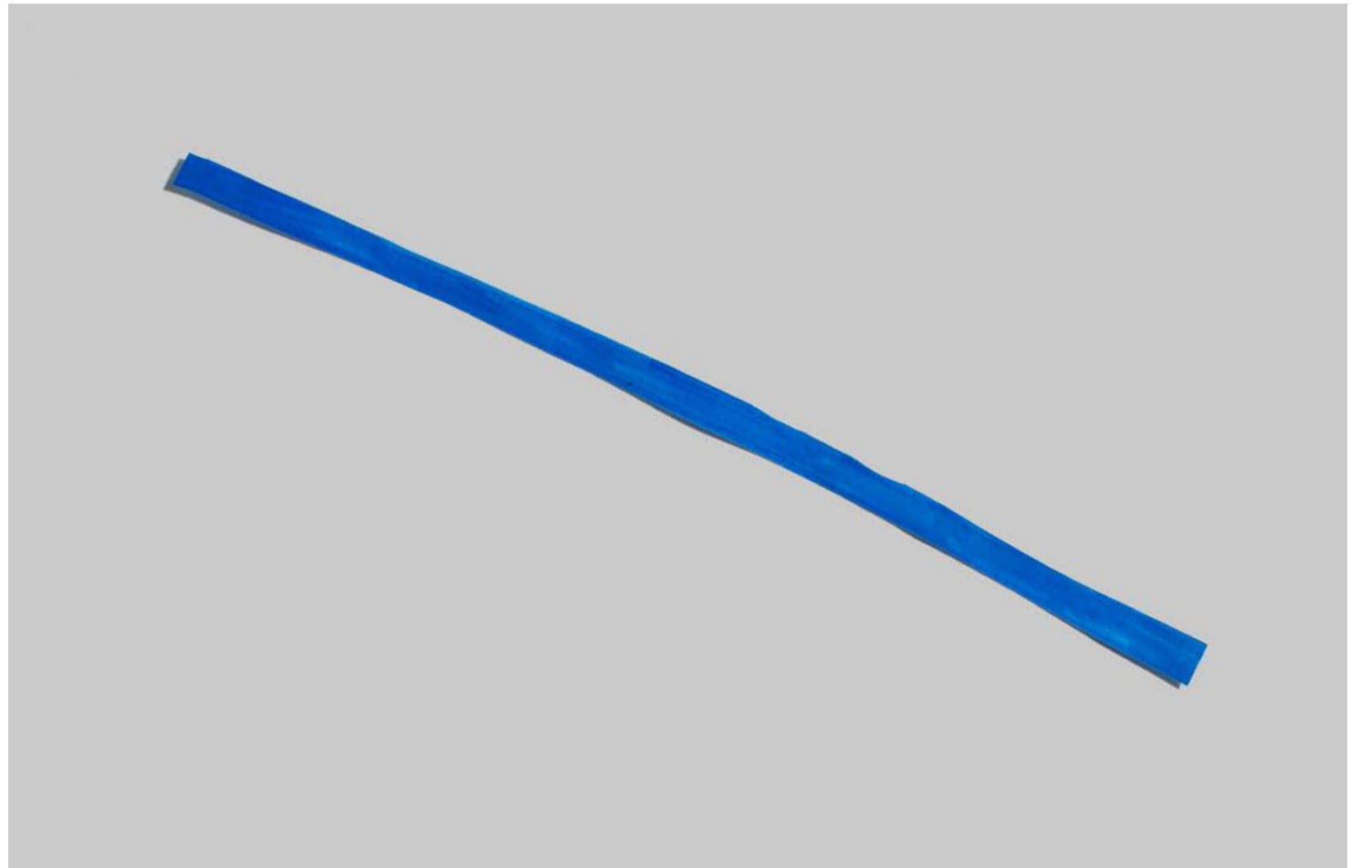



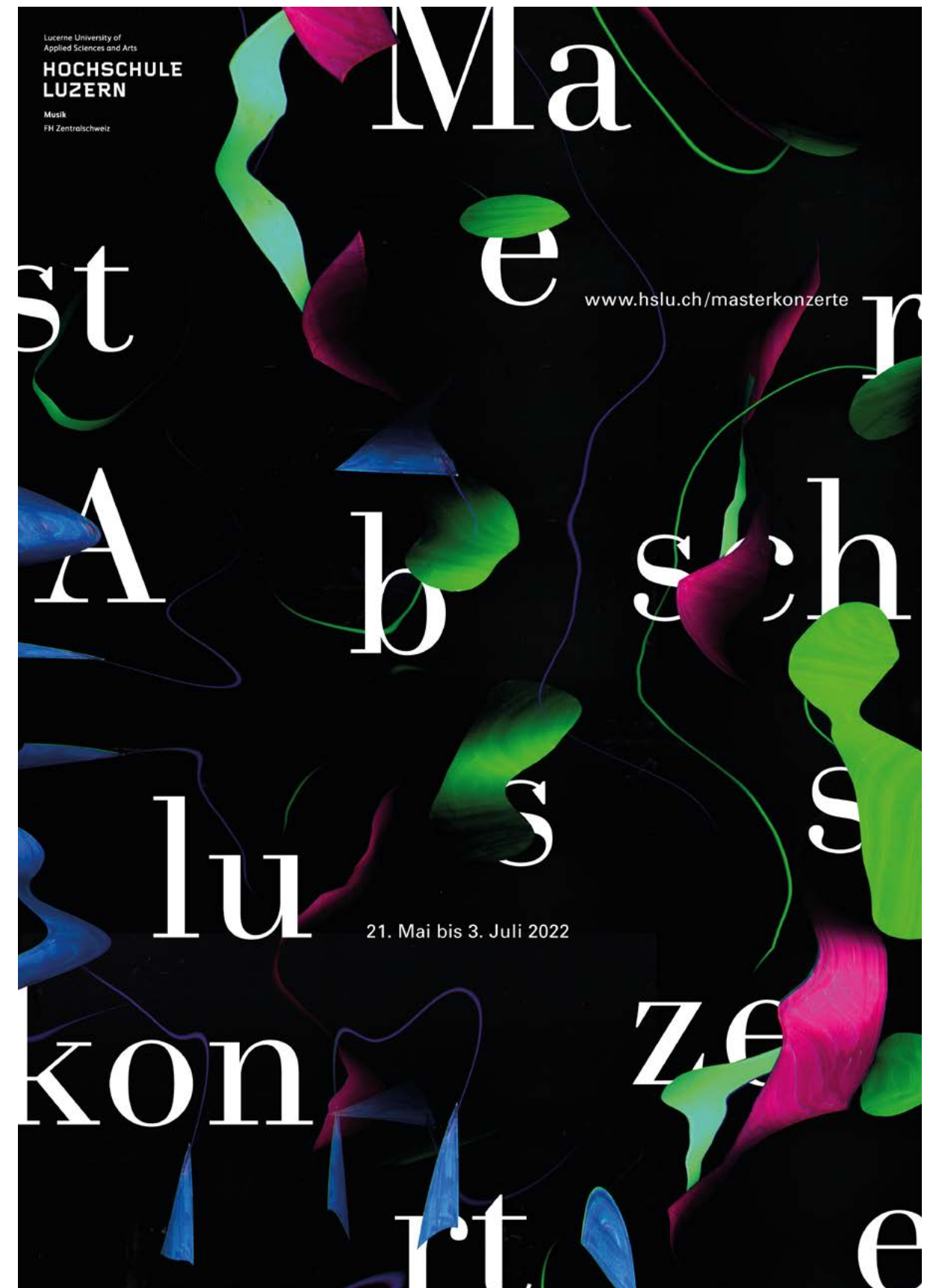

Die Spuren des Alltags

Layout, Fotografie, Zeichnen

August 2020



Unsere Aufgabe war es, einen zugeteilten Stadtteil während einer Woche visuell zu erfassen und dessen Charakter herauszuarbeiten. Ich beschäftigte mich mit den Spuren des Alltags. Dazu habe ich Bewegungen von Personen, Fahrzeugen und Tieren während einer Minute an verschiedenen Standorten zeichnerisch erfasst – Flugspuren von Vögeln, Laufspuren von Menschen oder Bewegungen von Verkehrsmitteln. Dieses Material fasste ich in einem kleinformatischen Layout zusammen. Die Legenden zeigen auf, woher welche Spuren stammen und wo diese erfasst wurden. Zu den Spuren habe ich beschreibende Satzfragmente gesetzt, die ich vor Ort wahrgenommen habe. Dies lässt Spielraum für die eigene Fantasie.

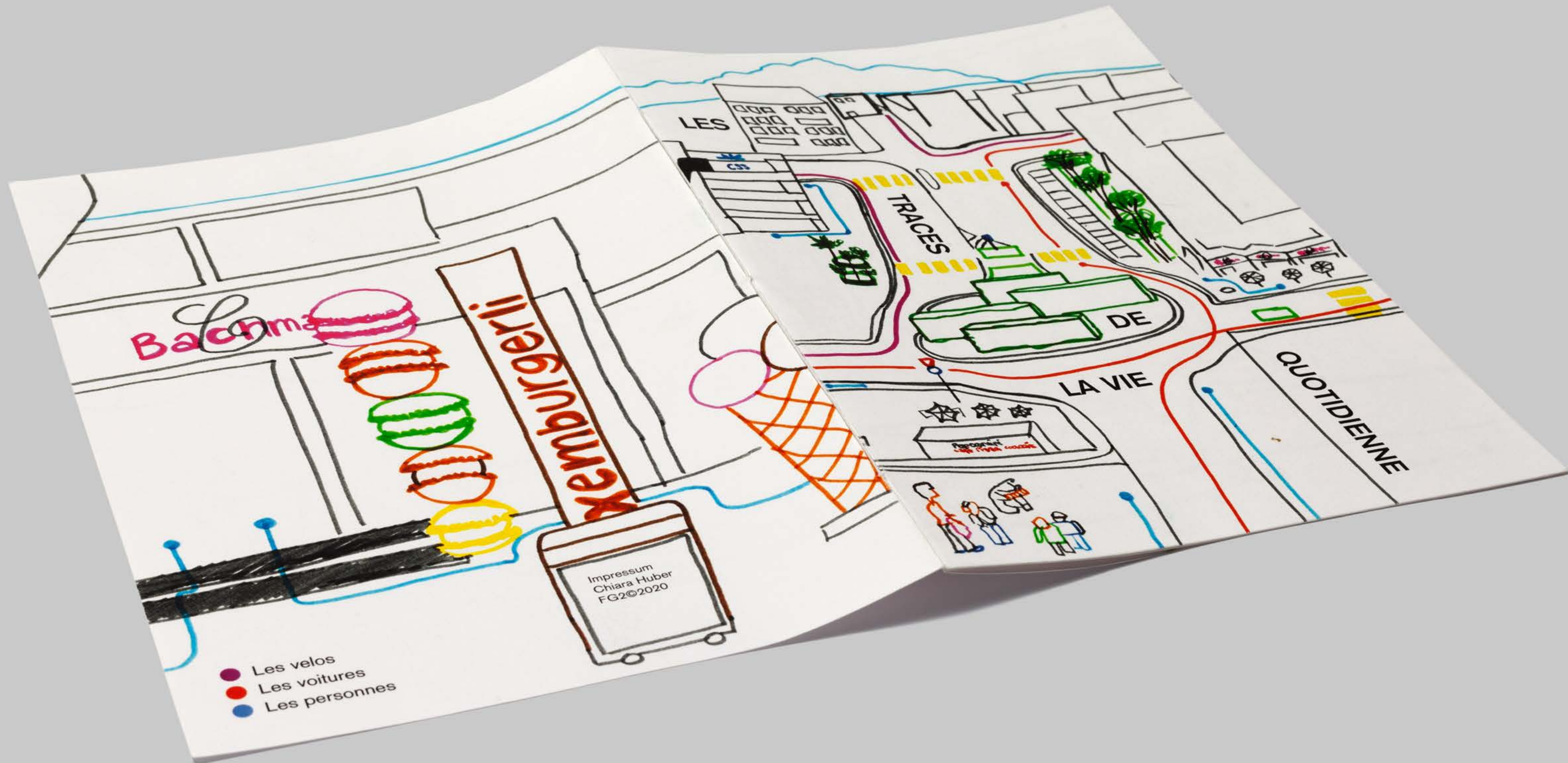

- Les velos
- Les voitures
- Les personnes

Impressum
Chiara Huber
FG2©2020

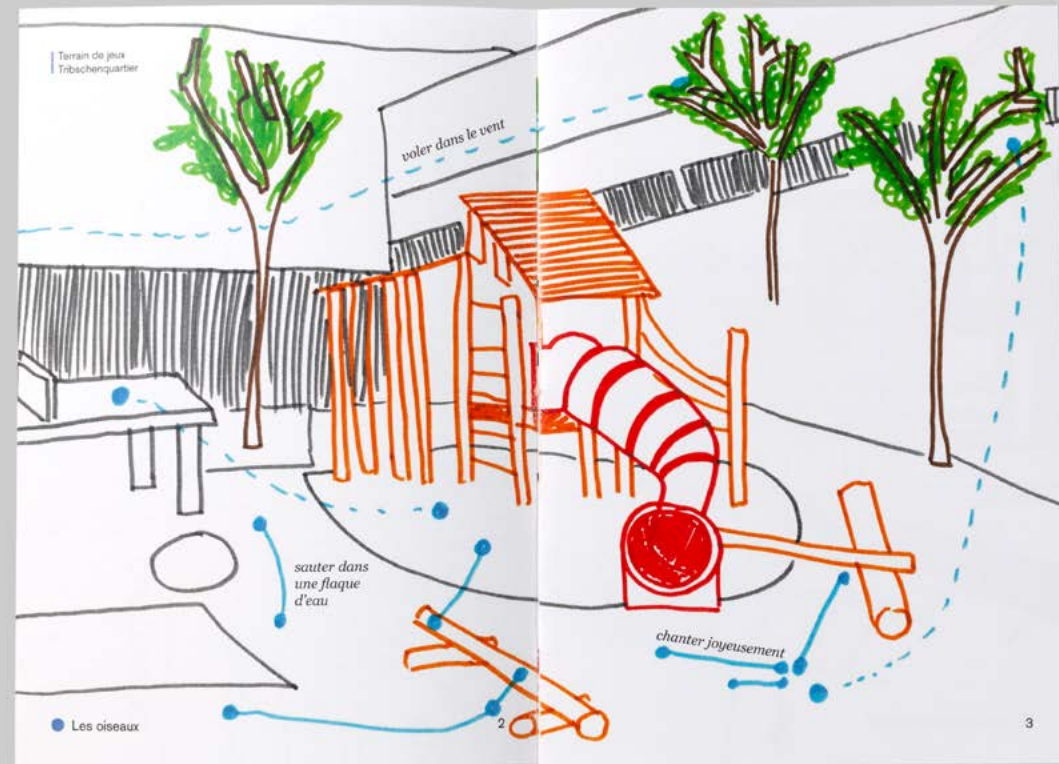
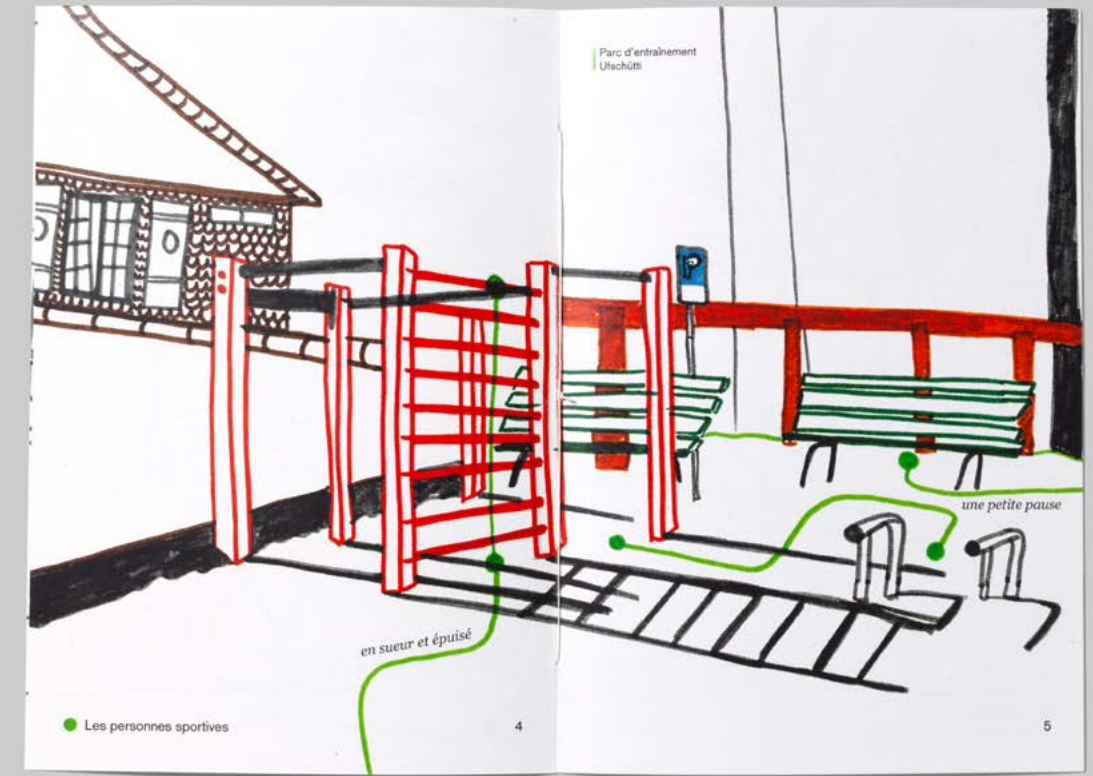
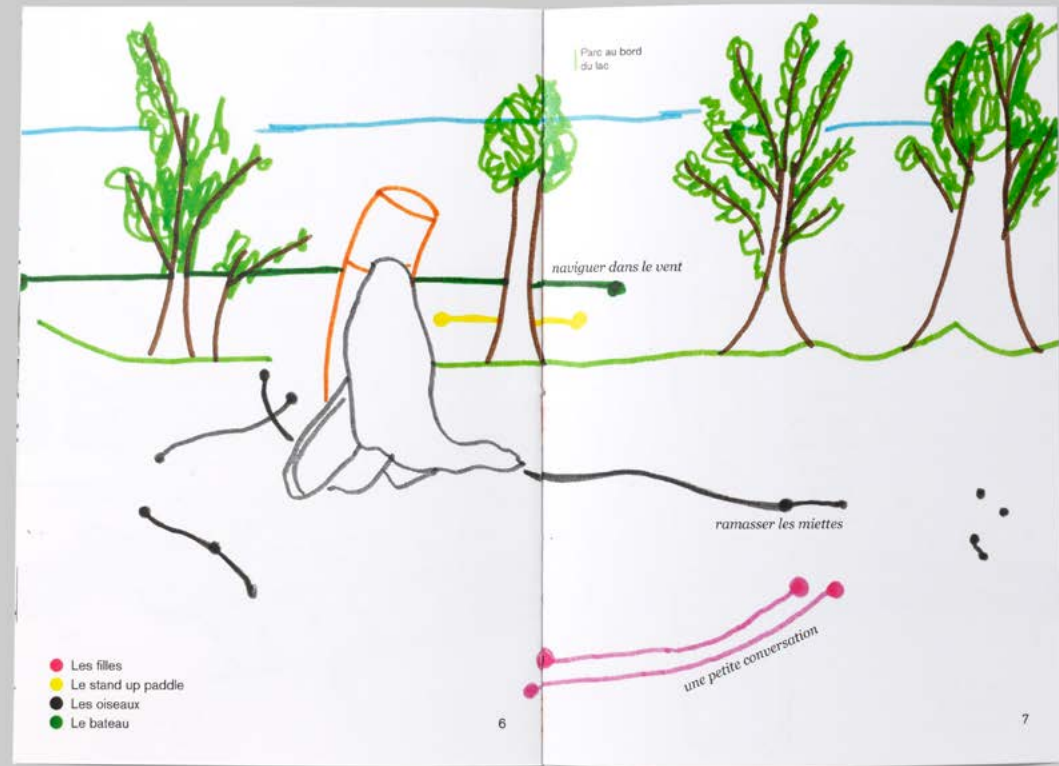

Terrain de jeux
Tribschenquartier



● Les personnes sportives

en sueur et épuisé



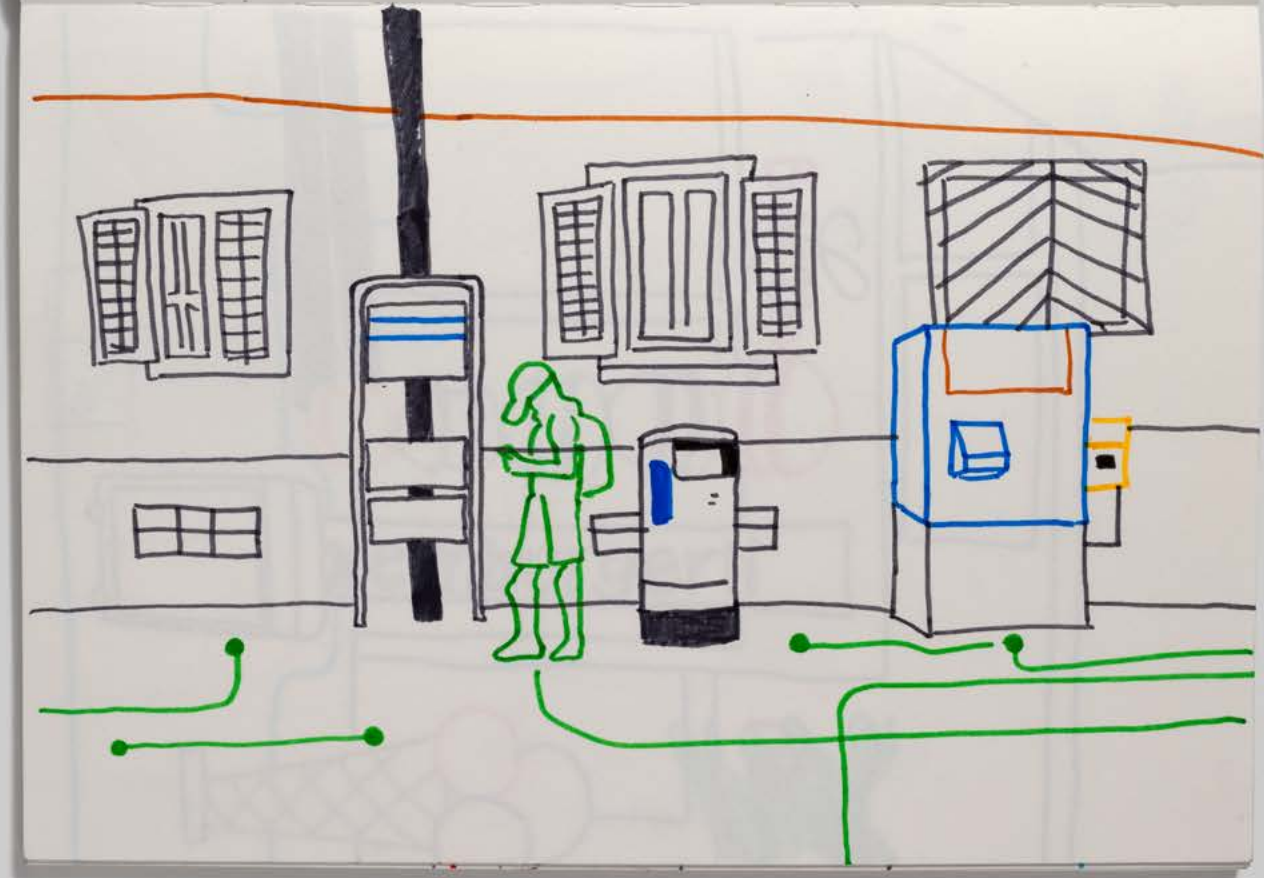
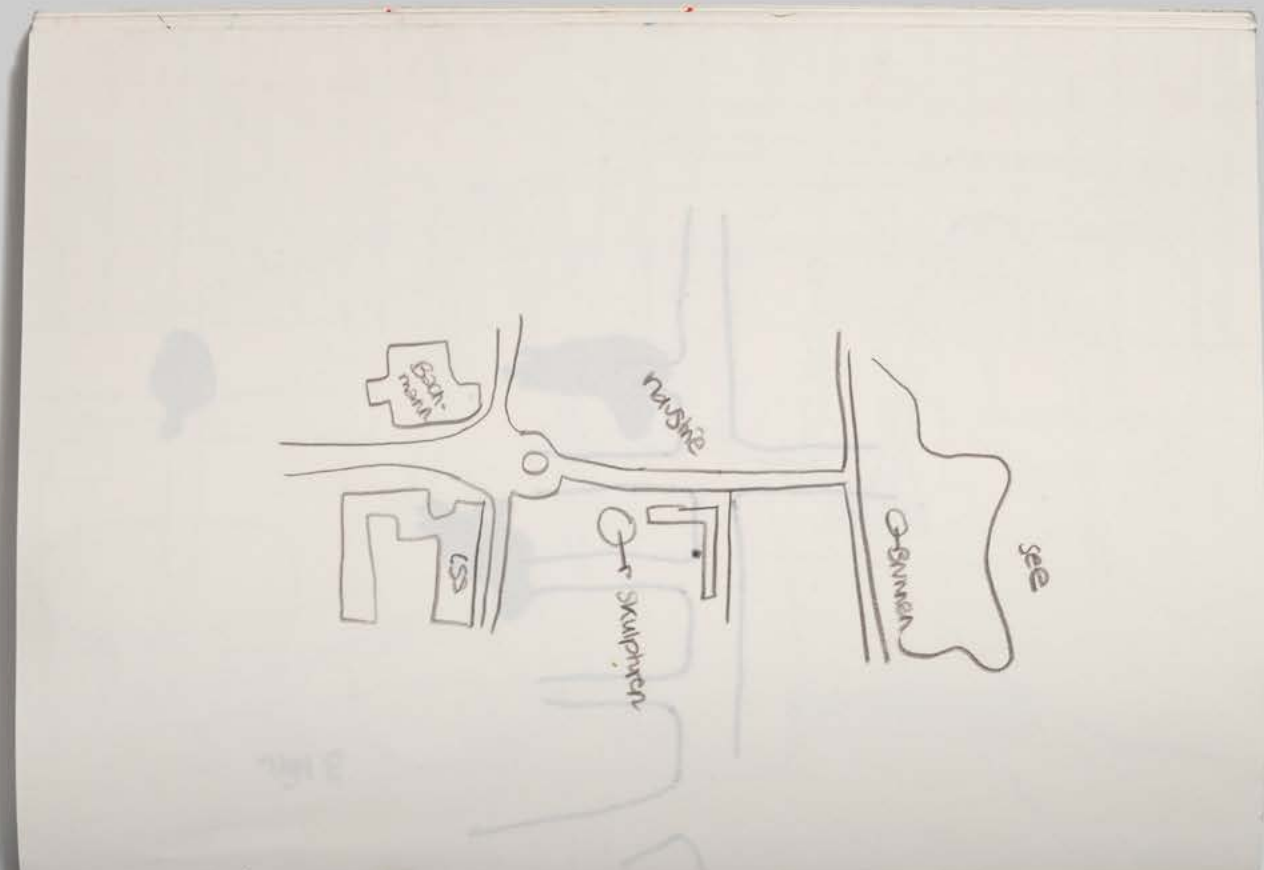
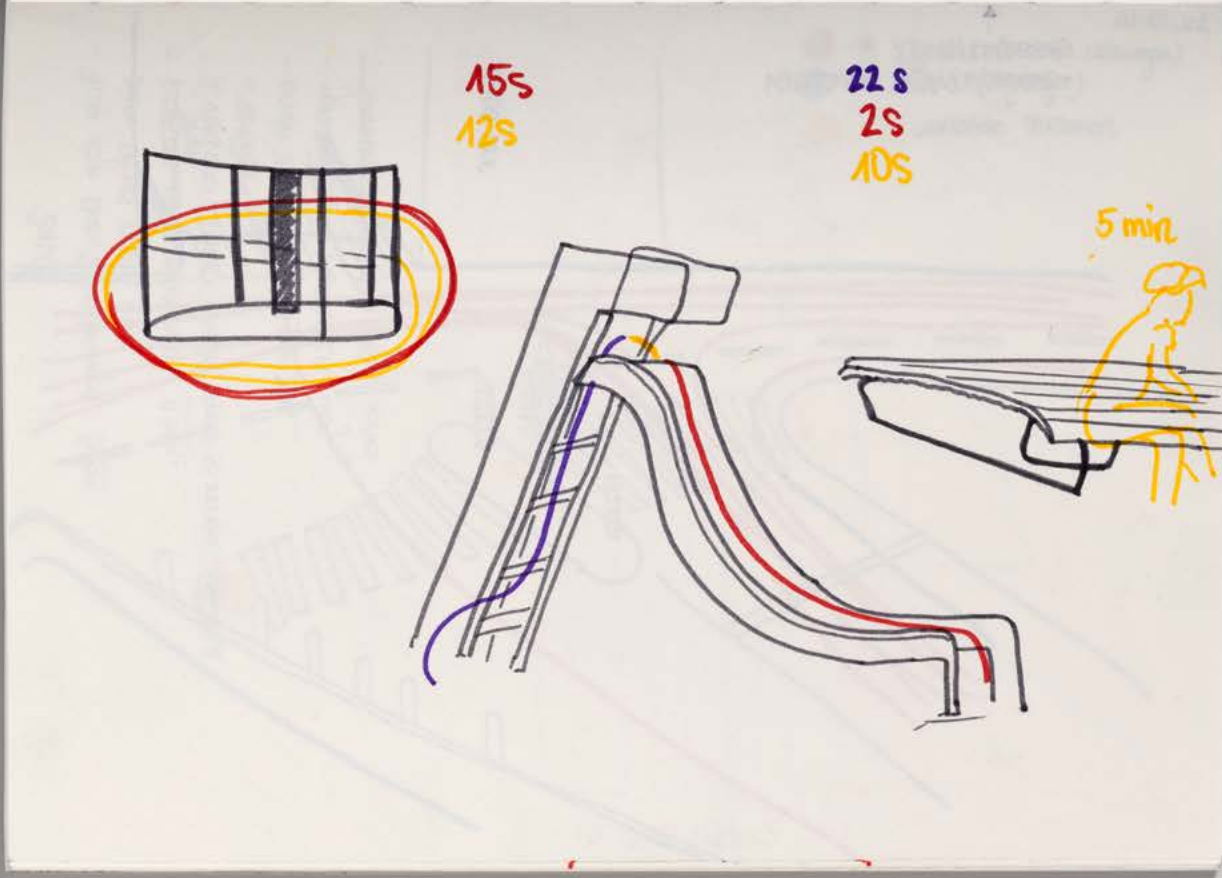
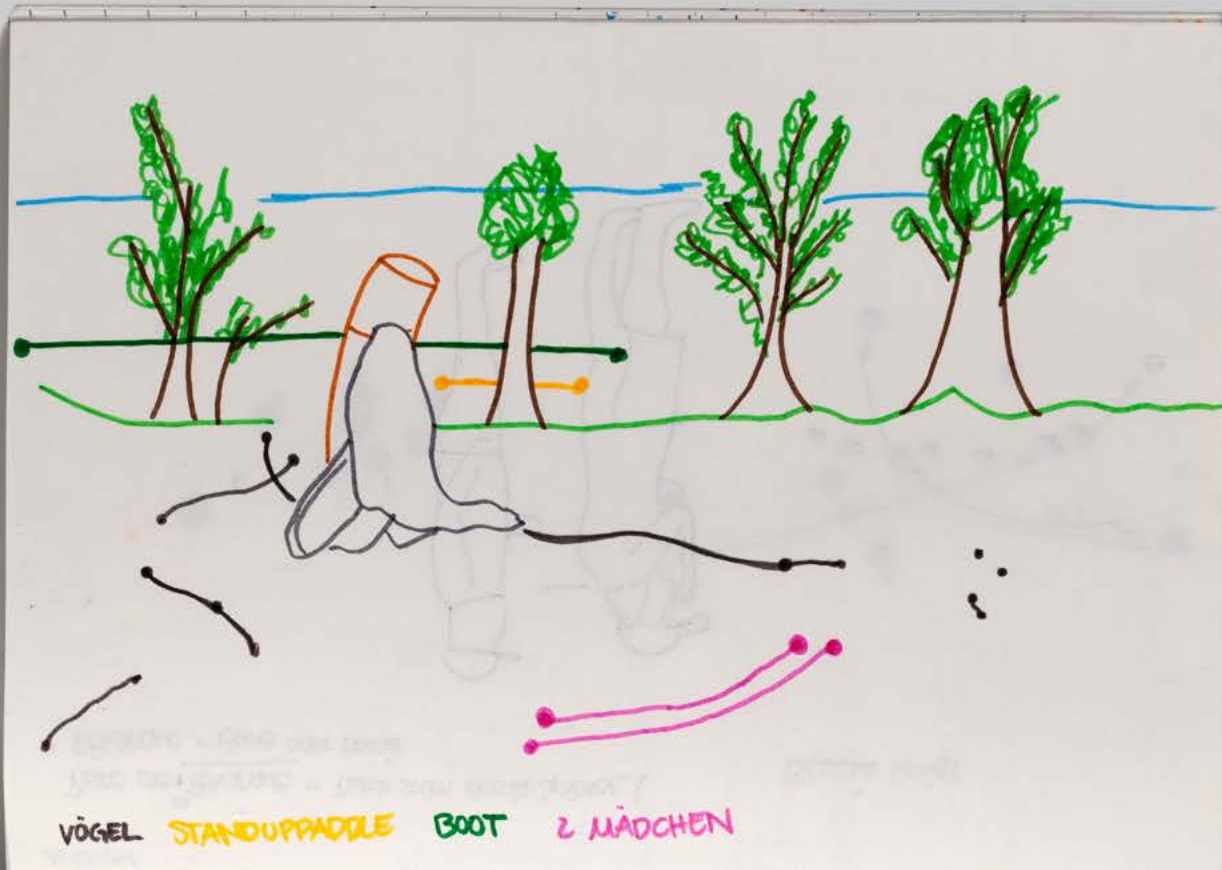



Kalligrafie

Kalligrafie, Font-Design

September 2019

Am Anfang des 1. Ausbildungsjahres entdeckte ich erstmals meine Faszination für die Schriftgestaltung im Kurs Kalligrafie. In einem ersten Teil erlernten wir mit Pinsel und Tusche die Kunst der Kalligrafie. In einem zweiten Teil gestalteten wir eine Wortmarke unter dem Begriff « Hapek ». Dieser beinhaltet wichtige Buchstabenteile, anhand denen man eine gesamte Schrift ableiten könnte. Ich gestaltete eine klassizistische Schrift mit hohem Strichstärkenunterschied und leichten Serifen.

! a b c c d e e f f g g

! g h h i i j k l m n o

! p q q r r r s s t u v

! w x y z f t e g s

Blume Stuhl
grau Katze
Handy o o b
Fachklasse gr

n v v v b w i z
baumign v k n
j g i g z x x h q e
l o s s s e n d a v

sunflower
abcdefghijkl
mnopqrstuv
wxyz

Нарек

Нарек

Нарек

Нарек

Нарек

Нарек

Hapeek

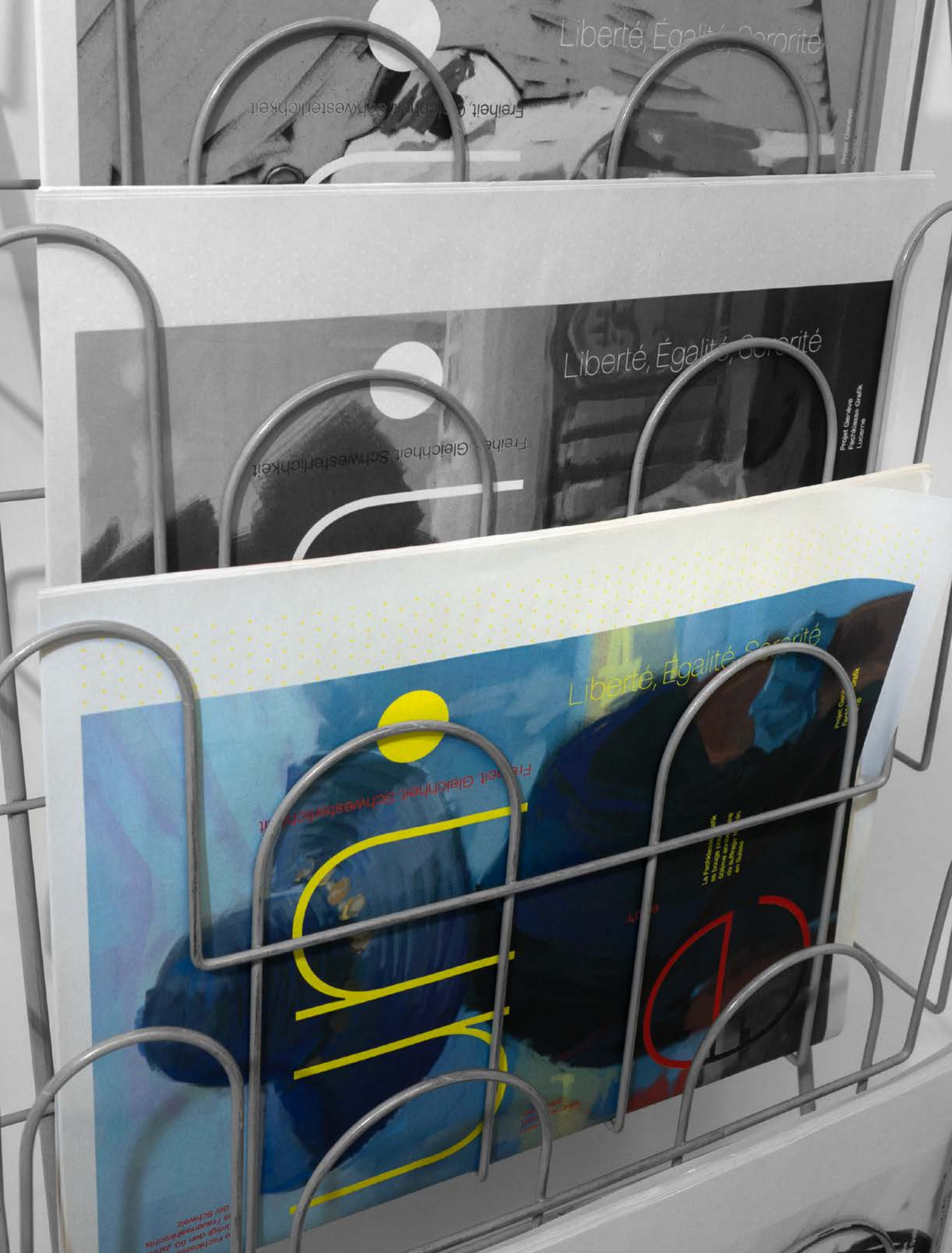

Die Damen sind die Stärksten

Layout, Fotografie, Zeichnen

September 2020

Während unserer Studienreise in Genf hielt ich mich während zwei Wochen im « Parc de Bastions » nahe der Altstadt auf. Die Schachbretter, welche sich am Eingang des Parks befanden, haben mich schon von Anfang an fasziniert. Was verbirgt sich hinter dem Schach - Spiel? Täglich recherchierte, skizzierte und fotografierte ich vor Ort. Zurück in Luzern gestaltete ich mit dem gesammelten Material fünf Seiten für eine Zeitungspublication. Mein gesamtes Layout ist auf einem Schachbrett - Raster aufgebaut. Inhaltlich befasste ich mich mit Zitaten zur Frage « Warum spielen mehr Männer Schach als Frauen? » Es geht es um Gleichberechtigung, Geschlechtsstereotypen, Sexismus und die Frage, warum Frauen automatisch als das schwächere Geschlecht bezeichnet werden.

Les dames sont les plus fortes.

Pensez-vous que les échecs étaient un simple jeu ? Non, c'est bien plus que ça et surtout le miroir de la vie passée et présente. Aux échecs, il y a un roi, deux fous, deux cavaliers, deux tours, huit pions et une seule dame.

Dans le Parc des Bastions à Genève, ce n'est pas très différent et j'ai surtout observé que seuls les hommes jouaient aux échecs. Les hommes sont-ils meilleurs et plus forts aux échecs ? Dans le jeu d'échecs lui-même, ce n'est pas le roi qui est la pièce la plus forte, mais la dame. Néanmoins, le roi est toujours plus haut dans la hiérarchie du pouvoir que la dame. Cette image se reflète encore aujourd'hui dans notre société et l'homme est encore supérieur à la femme dans certains domaines.

En partant de la question : « Pourquoi les hommes sont-ils plus nombreux que les femmes à jouer aux

échecs », vous en apprenez beaucoup sur l'égalité, les stéréotypes sexistes, le sexisme et la question de savoir pourquoi les femmes sont automatiquement appelées le sexe faible. Ensemble, elles sont fortes et ont acquis de nombreux droits au cours des dernières décennies, et cette lutte est loin d'être terminée.

© Le Mur des Réformateurs dans le Parc des Bastions
Das Reformationsdenkmal im Parc des Bastions

Die Damen sind die stärksten

Dachten Sie, Schach ist nur ein einfaches Spiel? Nein, es ist so viel mehr und vor allem der Spiegel des Lebens in der Vergangenheit, sowie auch in der Gegenwart. Im Schach gibt es einen König, zwei Läufer, zwei Springer, zwei Türme, acht Bauern und nur eine Dame.

Im Genfer Parc des Bastions ist es nicht viel anders und ich beobachtete mehrheitlich nur Männer, welche Schach spielten. Sind Männer besser und stärker im Schach? Im Schachspiel selbst ist nämlich nicht der König die stärkste Figur, sondern die Dame. Der König ist dennoch in der Machthierarchie immer höhergestellt als die Dame. Dieses Bild spiegelt sich bis heute auch in unserer Gesellschaft wider und der Mann ist immer noch in einigen Bereichen der Frau übergeordnet.

Anhand von Zitaten zur Frage: «Warum spielen mehr Männer Schach als Frauen?», erfahren Sie in meiner Projektarbeit viel über Gleichberechtigung, Geschlechtsstereotypen, Sexismus und die Frage, warum Frauen automatisch als das schwächere Geschlecht bezeichnet werden. Denn Frauen sind alles andere als schwach. Sie sind gemeinsam stark und erstritten sich in den vergangenen Jahrzehnten viele Rechte und dieser Kampf ist noch lange nicht beendet.

plus

sont



Le Parc des Bastions comme jeu d'échecs

Les dames



se fortes

Pensez-vous que les échecs étaient un simple jeu ? Non, c'est bien plus que ça et surtout le miroir de la vie passée et présente. En citant la question : « Pourquoi les hommes sont-ils plus nombreux que les femmes à jouer aux échecs », ils en apprennent beaucoup sur l'égalité, les stéréotypes sexistes, le sexisme et la question de savoir pourquoi les femmes sont automatiquement appelées le sexe faible.

Chiara Huber

Les échecs sont-ils le miroir de la vie ?

Aux échecs, il y a un roi, deux fous, deux cavaliers, deux tours, huit pions et une seule dame.

Dans le Parc des Bastions de Genève, ce n'est pas très différent. J'ai observé les jeux d'échecs en plein air échecs du parc pendant presque deux semaines et rapidement, je me suis rendu compte que pratiquement seuls les hommes jouaient ici aux échecs. Des hommes en costume ou des touristes mais aucune femme.

Les hommes ont monopolisé chaque jour les six échiquiers à l'entrée du parc. Seules quelques femmes ont osé jouer ou ont apprécié le jeu de dames à côté des échiquiers. Les femmes se sentent-elles obligées de jouer aux dames parce que le jeu porte leur nom ou parce que le jeu de dames est subordonné aux échecs ?

« Pourquoi les hommes sont-ils plus nombreux que les femmes à jouer aux échecs ? » Cette question occupait mon esprit. La meilleure façon d'obtenir une réponse à ma question était de demander directement l'avis des joueurs d'échecs locaux. J'ai reçu des réponses et des arguments intéressants, et qui m'ont fait réfléchir.



06.09.2020 14:50

09.09.2020 14:28



09.09.2020 14:29



12.09.2020 13:04



12.09.2020 13:08



« C'est un jeu de guerre et de combat. »

Joueur d'échecs cubain



08.09.2020 12:33

Les échecs sont un jeu dans lequel la logique et la stratégie sont les principaux enjeux. Mais dès sa conception, les échecs sont un jeu de guerre et de combat, car deux armées hostiles sont en guerre l'une contre l'autre.

Dans nos esprits, il y a encore une image forte du passé : la guerre est l'affaire des hommes. Les femmes peuvent aider mais pas se battre. D'une certaine manière, il y a beaucoup de vérité dans cet argument, car c'est précisément à cause de ce modèle que beaucoup de femmes ne peuvent probablement pas s'identifier facilement aux jeux de guerre.

Mais les femmes se sont battues pour de nombreux droits au cours des dernières décennies. Ensemble elles sont fortes et elles peuvent donc très bien se battre !

Les échecs :

Le nom d'échecs est dérivé du « Shah » (roi) persan, d'où le nom de « jeu royal ». Le but du jeu est de mettre l'adversaire en échec et mat. C'est-à-dire attaquer son roi de telle manière qu'il ne lui est pas possible de se défendre ou de s'échapper.

Parc des Bastions :

Près de la vieille ville se trouve le Parc des Bastions, un grand espace vert au centre de la ville. Le long des avenues ombragées, on peut parfaitement se promener et admirer le monument impressionnant de la Réformation. Le Palais Eynard, la grande bibliothèque de Genève et l'Université de Genève y sont également situés.

Jeu de dames :

Le jeu de dames est un jeu de plateau stratégique et ressemble beaucoup aux échecs, il est donc également joué sur le même plateau. L'objectif est de prendre les pions de l'adversaire en sautant par-dessus ses pièces. Le perdant est celui qui n'a plus de pions ou qui ne peut pas les déplacer.

Chiara Huber

« C'est un problème de machisme et de la société patriarcale. »

Joueur d'échecs français



Les hommes ont un pouvoir sur les femmes. Une société patriarcale décrit exactement cette structure. Dans le passé, les hommes étaient le chef de famille et avaient donc le pouvoir. Ils pouvaient opprimer, humilier ou contrôler les femmes. En bref, les hommes ont régné sur les femmes. Mais pourquoi les hommes devraient-ils valoir plus que les femmes !

Dans le Parc des Bastions lui-même, il n'y a qu'une sculpture féminine parmi des dizaines d'hommes. Les réformateurs sont tous des hommes et la seule femme, Marie Dentière, a été cisélée en petit à côté de Zwingli.

Aujourd'hui, cette situation s'est considérablement améliorée, et pourtant, dans de nombreux domaines, l'égalité est encore loin d'être acquise.

06.09.2020 15:25



Société patriarcale :

Une société patriarcale décrit une structure générale dans laquelle les hommes ont un pouvoir sur les femmes. Les hommes ont plus de privilèges et sont supérieurs aux femmes. Le contraire serait alors le matriarcat. Une autre société dans laquelle les mères et les femmes ont le premier mot à dire.

Les réformateurs :

Les quatre statues de William Farel, John Calvin, Théodor Bèze et John Knox se trouvent sur le Monument de la Réformation. Ces quatre personnes sont considérées comme les principaux représentants du calvinisme. En face de ce mur se trouve un escalier dans les murs latéraux duquel sont gravés les noms de « Luther » et « Zwingli ».

Marie Dentière :

Elle est la seule femme honorée au Monument de la Réforme à Genève. Les femmes devaient être autorisées à prêcher comme les hommes. Cette demande est devenue son message central. Elle a publié des écrits théologiques et historiques, est intervenue dans des débats et a lutté pour l'égalité des droits entre les hommes et les femmes.

Les dames sont les plus fortes

« Les femmes sont comme des renards. Elles sont trop intelligentes. »

Joueur d'échecs mexicain



Est-ce la raison pour laquelle les femmes ont été autorisées à étudier et à enseigner dans les universités si tardivement ? Les hommes ont-ils permis aux femmes d'entrer si tard dans les universités par crainte qu'elles ne deviennent plus intelligentes ? Mais en réalité, université signifie « universel », c'est-à-dire « accessible à tous ». Il est certain que si les femmes réussissent dans leur carrière, l'image des stéréotypes sexuels aurait complètement changé. L'homme au fourneau et la femme au travail. Autrefois inimaginable et maintenant tout à fait possible.

Depuis 1864, après de nombreuses années et diverses manifestations, les femmes ont été autorisées à étudier. Le symbole de la femme pulvérisée est encore visible aujourd'hui sur les escaliers de l'Université de Genève.

Aux niveaux hiérarchiques supérieurs, les femmes sont légèrement mieux représentées à Genève que dans les autres universités, et pourtant le nombre de femmes aux niveaux supérieurs diminue sensiblement, alors que les hommes sont représentés en grand nombre. Bien sûr, cela reste lié à la répartition des rôles selon le sexe.

Les femmes doivent choisir soit une carrière, soit une famille. La plupart des femmes choisissent d'avoir des enfants et un foyer, c'est pourquoi elles ne trouvent pas tout le temps nécessaire pour suivre des études supérieures. La répartition des rôles a également changé au fil des ans et aujourd'hui, les femmes ne sont plus les seules responsables des enfants. Elles ne sont plus les seules responsables du ménage et de l'éducation des enfants et vont aussi travailler.

L'égalité en chiffres à l'unige

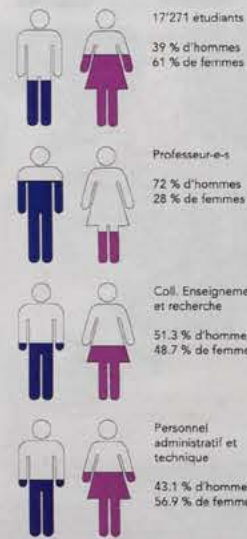

06.09.2020 15:38

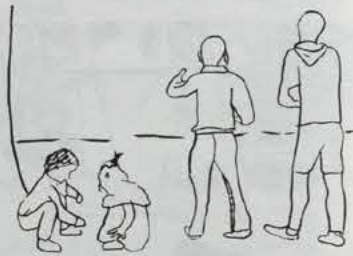

L'université de Genève : L'université de Genève a été fondée par Jean Calvin en 1559 sous le nom d'Académie théologique et humaniste de Genève. Depuis 1980, Genève est la seule université de Suisse où les femmes sont plus nombreuses que les hommes à étudier.

Les stéréotypes sexuels : Les stéréotypes sexistes comprennent, d'une part, des notions simplistes sur la façon dont les femmes et les hommes sont en général et des attentes sur ce qu'ils devraient et ne devraient pas être.

Le symbole de la femme : Le pouvoir féminin, la force, l'indépendance, l'autodétermination. Avec le début du nouveau mouvement des femmes dans les années 1970, le signe de femme est devenu le symbole et l'expression des féministes et des lesbiennes. Le symbole est un poing serré au centre du signe de Vénus.

Les dames sont les plus fortes

Un regard plus attentif sur les pièces d'échecs.



La dame Le dame est la pièce la plus puissante et la plus dangereuse des échecs. Elle peut se déplacer horizontalement, verticalement et en diagonale, mais ne peut sauter par-dessus les pièces. Elle est l'allée la plus précieuse de son roi et l'ennemi le plus puissant de son adversaire.



Le roi Le roi correspond au modèle historique classique. La figure la plus puissante, mais aussi la plus vulnérable de la société. Le roi et les pions, aussi différents que soient ces deux figures, ont une chose en commun : ils ne se déplacent que d'une seule case sur l'échiquier.



Le fou Le fou ressemble au pion, mais il est beaucoup plus grand. Il peut se déplacer d'autant de cases en diagonale qu'il le souhaite, mais il ne peut sauter aucune pièce. L'évêque ne peut pas changer de couleur de case.



Le cavalier Le cavalier est souvent appelé cheval, car il symbolise les cavaliers ou la cavalerie. Il se déplace toujours en forme de L et est donc imprévisible, comme une cavalerie qui apparaît à l'improviste et contourne rapidement les fantassins. Le cavalier peut sauter par-dessus d'autres pièces.



La tour Les modèles historiques de la tour sont les machines de combat, des tours de siège ou des bataux de guerre. Il s'agit donc d'une figure à la fois forte et simple. La tour se déplace toujours horizontalement et verticalement.



Le pion Le pion incarne les valets de la cour. C'est la pièce la plus faible des échecs et elle ne peut avancer que d'une case par coup. Cependant, s'il atteint la ligne de base de l'adversaire, il peut se transformer en n'importe quelle pièce. Il est également décrit comme « l'âme des échecs ».

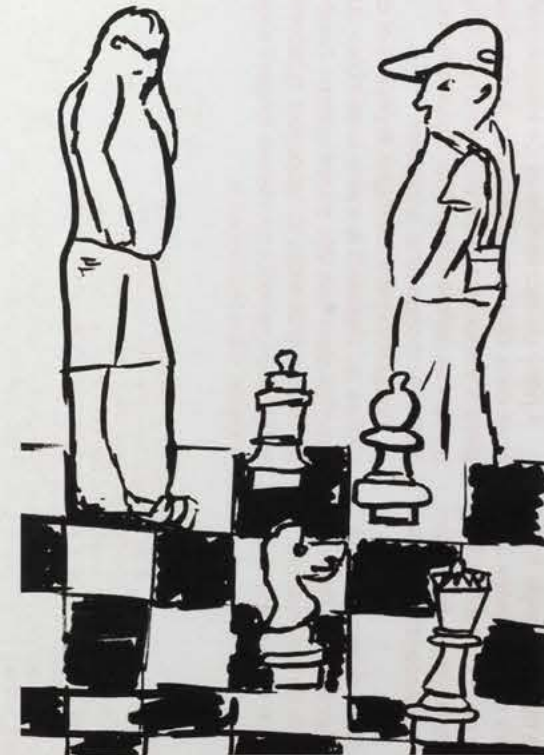

Chiara Huber © Fachklasse Grafik Lucerne 2020 Sources textuelles : www.unige.ch www.greelane.com www.geneve.com www.wikipedia.org www.spielazar.ch www.bzw.weiterdenken.de

Chiara Huber



www.kidzart.com



Ella Boccia

« un roi, deux fous, deux
urs, huit pions et une

« Bastions de Genève,
Brens. J'ai observé les jeux
d'échecs du parc pen-
sant que pratiquement
seulement, des hommes
se ou des touristes mais
inoposé chaque jour les
trée du parc. Seules
it osé jouer ou ont app-
e sentent-elles obligées
arce que le jeu porte
ue le jeu de dames est
es ?

es sont-ils plus nom-
à jouer aux éch-
occupait mon esprit.
obtenir une réponse
demander directement
ces locaux. J'ai reçu
uments intéressants,
ir.

« C'est un jeu de guerre et de combat. »

Joueur d'échecs cubain

08.09.2020
12:33



09.09.2020
14:29



12.09.2020
13:04



12.09.2020
13:08



Les échecs sont un jeu dans lequel la lo-
gique et la stratégie sont les principaux
enjeux. Mais dès sa conception, les échecs
sont un jeu de guerre et de combat, car
deux armées hostiles sont en guerre l'une
contre l'autre.

Dans nos esprits, il y a encore une image
forte du passé : la guerre est l'affaire des
hommes. Les femmes peuvent aider mais
pas se battre. D'une certaine manière,
il y a beaucoup de vérité dans cet argument,
car c'est précisément à cause de ce mo-
dèle que beaucoup de femmes ne peuvent
probablement pas s'identifier facilement
aux jeux de guerre.

Mais les femmes se sont battues pour de
nombreux droits au cours des dernières
décennies. Ensemble elles sont fortes et elle
peuvent donc très bien se battre !



L'égalité en chiffres
à l'unige

17'271 étudiants
39 % d'hommes
61 % de femmes

Professeur-e-s
72 % d'hommes
28 % de femmes

Coll. Enseignement
et recherche
51.3 % d'hommes
48.7 % de femmes

Personnel
administratif et
technique
43.1 % d'hommes
56.9 % de femmes

es sont
fortes

Université de Genève :
de Genève a été fondée par Jean
le nom d'Académie
de Genève. Depuis
Université de
heures

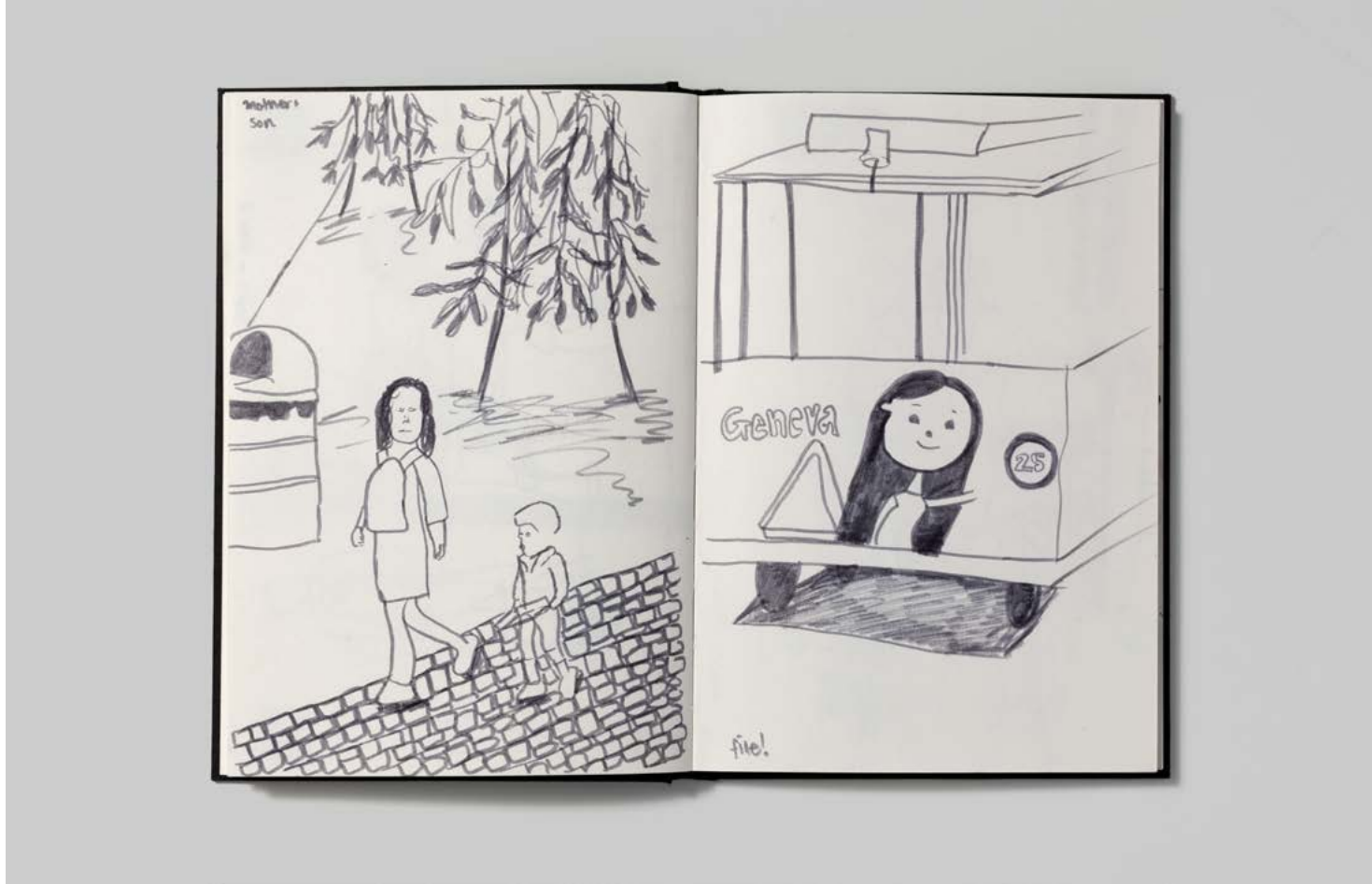
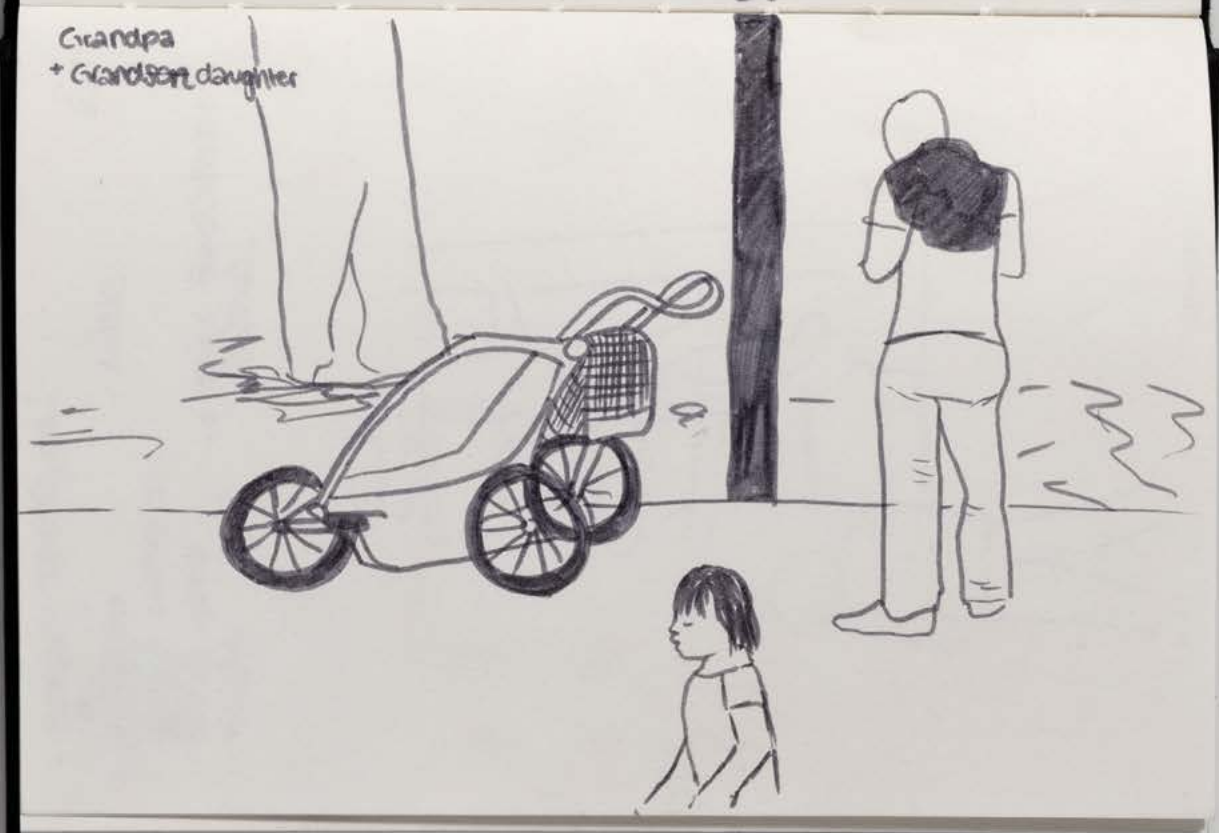
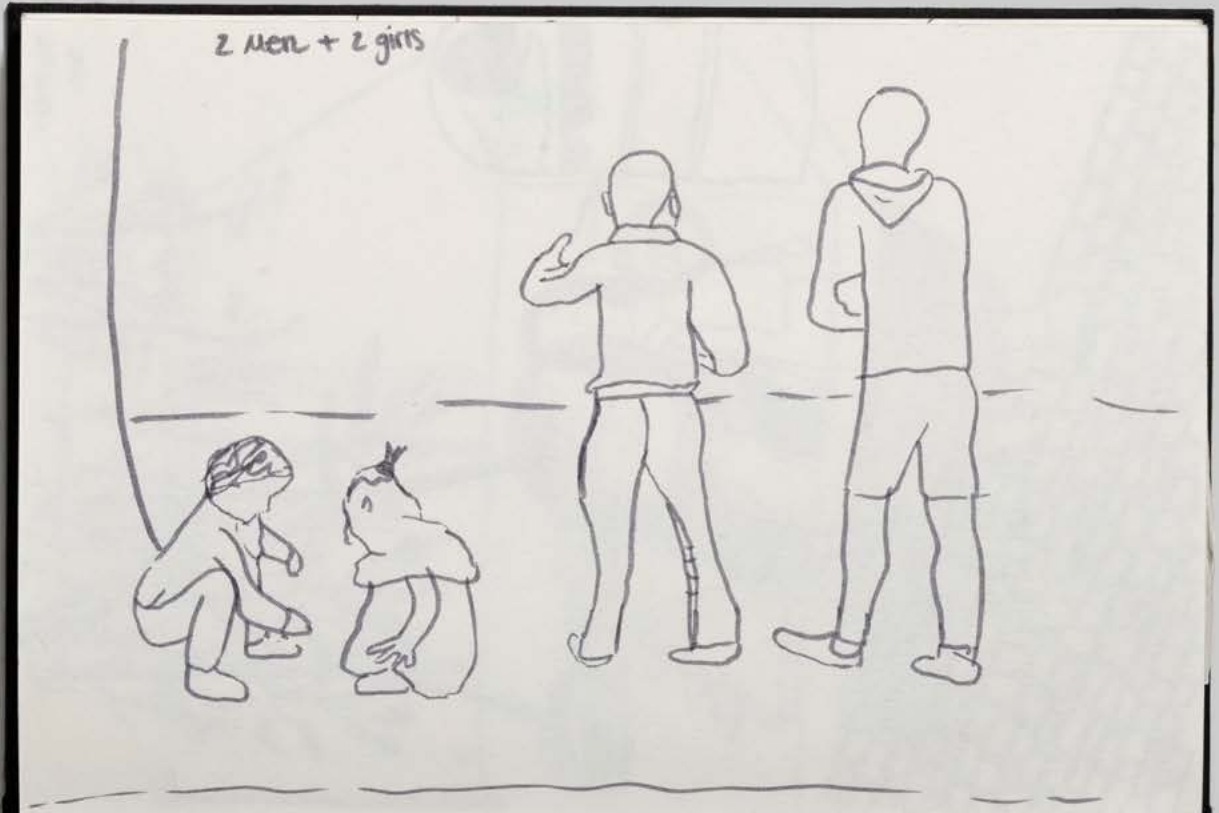

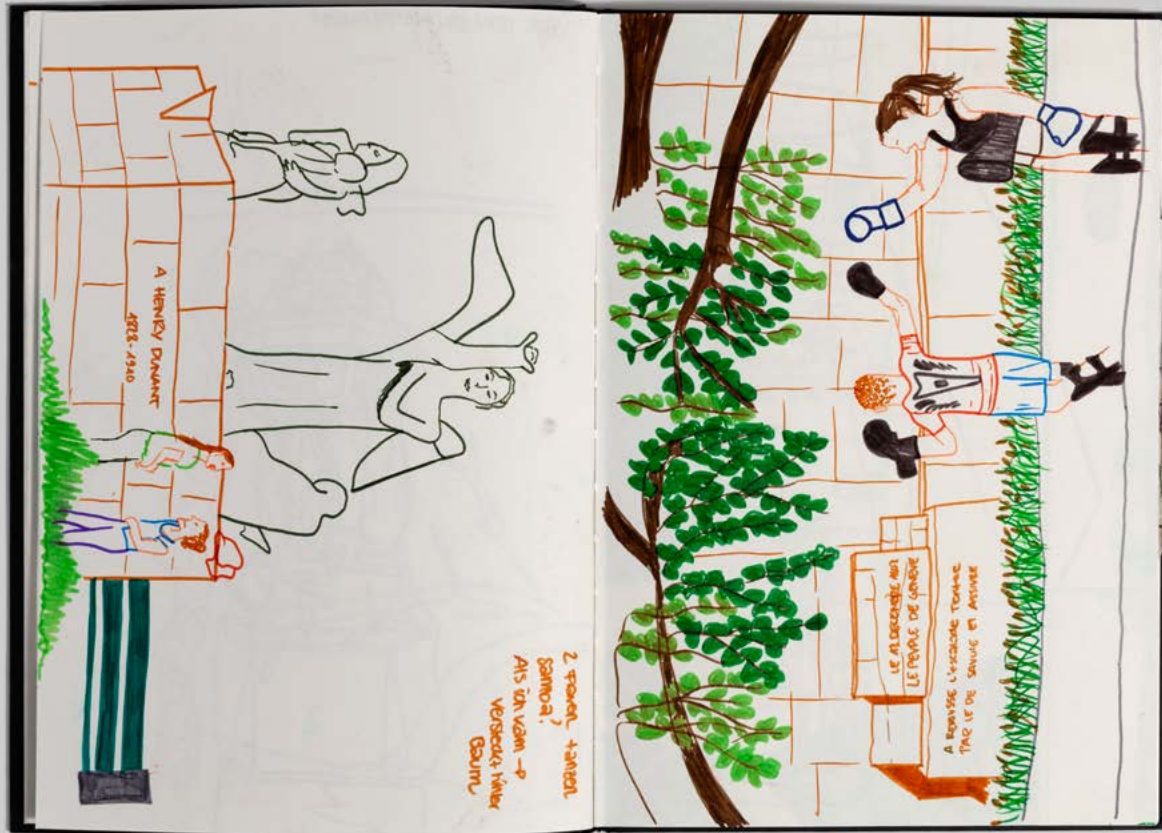

Universität Genève

Hier, hat die Homophobie viele Opfer gemacht! → *Sticker auf Boden*

- Ici, l'homophobie a fait une victime.

homophobie → Aggressivität gegen lesbische + schwule Personen.

#UNI UNIF contre le harcèlement
gegen Belästigung

(www.unige.ch) université genève

- espace allègement → *Stuhlbum?*

FRAUENSYMBOL (auf Treppe Genfer Universität)
Gebäude Festsch

AGIR QUAND ON SE SENT MENACÉ(E)
Qu'est-ce qu'une menace?
Parole, écrit, geste ou comportement menaçants, visant une personne en particulier et inspirant un sentiment d'insécurité, même sans danger imminent. Une menace non prise en charge pourrait aboutir ultérieurement à un acte de violence. Tout membre de la communauté universitaire se sentant personnellement menacé ou ayant connaissance de menaces proférées ou pressenties au sein de la communauté universitaire peut écrire à: respect@unige.ch

En présence d'une **menace précise et imminente** (attaque à main armée, prise d'otage, séquestration, menace de suicide imminent, etc.), appeler immédiatement le 117 puis avertir la sécurité interne au 1222.

Pour en savoir plus: www.unige.ch/respect

UNIVERSITÉ DE GENÈVE

SANTÉ AU TRAVAIL, ENVIRONNEMENT, PRÉVENTION, SÉCURITÉ

Veränderung mit eigener Erfahrung





Anamorphose

Fotografie, Film, Typografie

Juni 2021

Weltformat Graphic Design Festival

In Zusammenarbeit mit Arno Röthlin und Elena Kaeslin drehte ich einen Kurzfilm und gestaltete Plakate für die Workshops « Weltklasse », welche jeweils durch die Fachklasse Grafik Luzern im Rahmen des « Weltformat Graphic Design Festival » organisiert werden. Wir beschäftigten uns mit dem Thema Anamorphose, genauer mit der Wahrnehmung eines Wortes aus einem ganz bestimmten Blickwinkel. Dazu konstruieren wir eine anamorphotische Installation aus selbst gebauten Körpern.

Link zum Video: <https://chiarahuber.ch/projects/anamorphose/index.html>



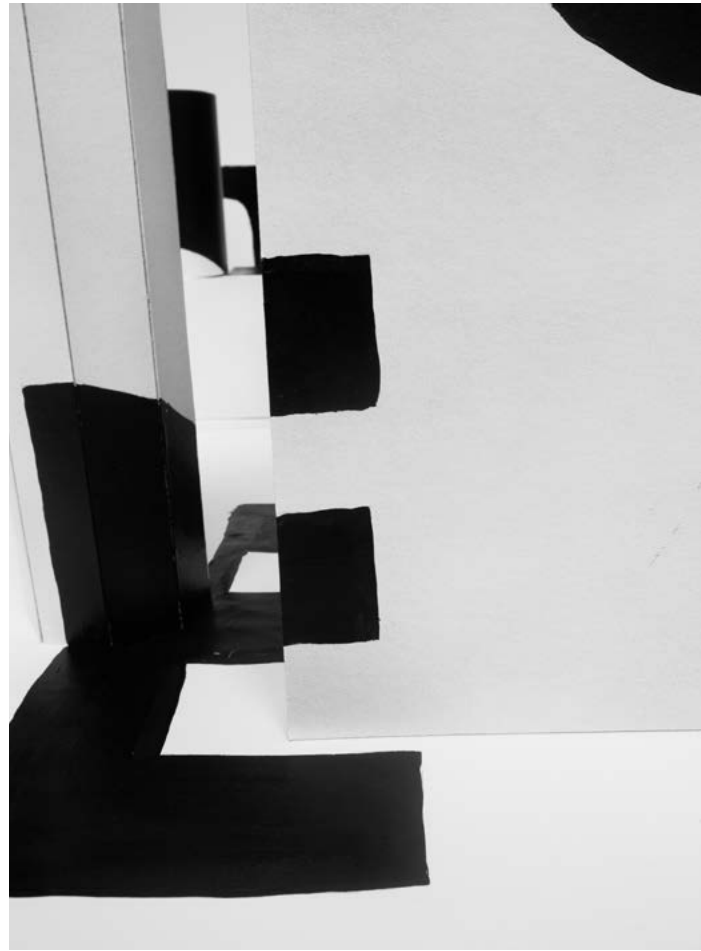
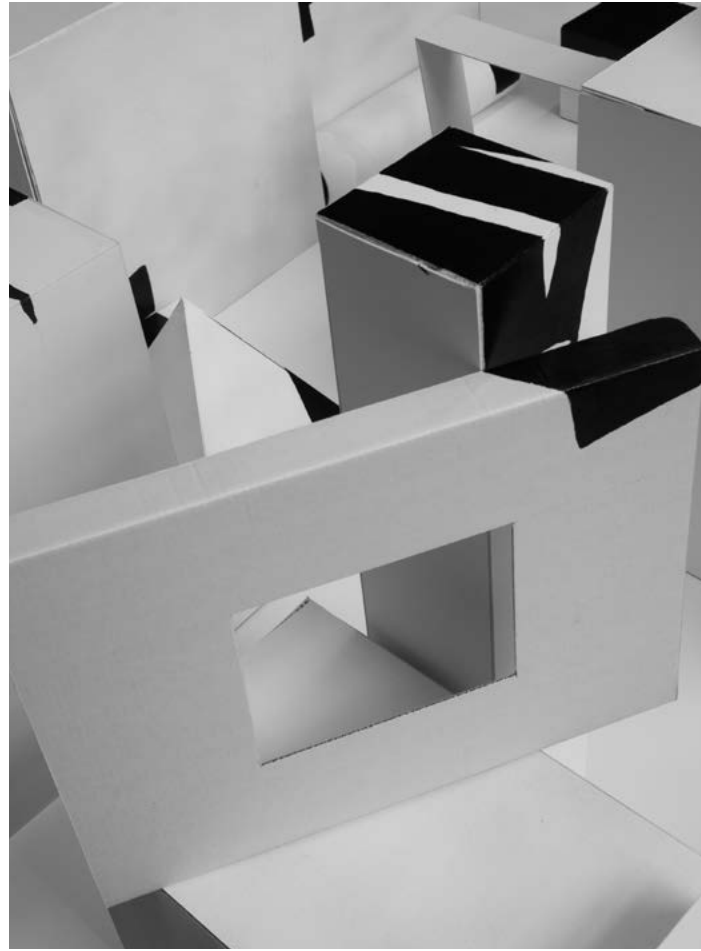

0123456789
abcdefghijklmnop
qrstuvwxyzäöü.,-'

Text 1 Spalte 24pt/30.5pt
es gibt mittlerweile codes, die besser als die schriftzeichen informationen übermitteln. was bisher geschrieben wurde kann besser auf tonbänder, schallplatten, filme, videobänder, bildplatten oder disketten übertragen werden. und vieles was bislang nicht geschrieben werden konnte, ist in diesen neuen codes notierbar. die derart codierten informationen sind bequemer zu erzeugen, zu übertragen, zu empfangen und zu speichern als geschriebene texte.

Text 2 Spalte 12pt/15pt
schreiben im sinne einer aneinanderreihung von buchstaben und anderen schriftzeichen scheint kaum oder überhaupt keine zukunft zu haben. es gibt mittlerweile codes, die besser als die schriftzeichen informationen übermitteln. was bisher geschrieben wurde kann besser auf tonbänder, schallplatten, filme, videobänder, bildplatten oder disketten übertragen werden. und vieles was

bislang nicht geschrieben werden konnte, ist in diesen neuen codes notierbar. die derart codierten informationen sind bequemer zu erzeugen, zu empfangen und zu speichern als geschriebene texte.

Schriftgestaltung: Meinhardt & Meunier

chi
h

Lens font

Illustration, Font - Design

Januar 2020

Um uns mit dem Programm Adobe Illustrator vertraut zu machen, zerlegten und analysierten wir ein elektronisches Gerät. Ich entschied mich für meine alte Fotokamera und machte in einem ersten Schritt eine digitale Bestandsaufnahme. Aus einer Dekonstruktion entstanden viele spannende Formen und ich kreierte daraus erste Buchstaben. Aus den Einzelteilen der Linse leitete ich schlussendlich in einem spannenden Prozess die Gestaltung meiner serifenlosen Schrift « lens » ab.

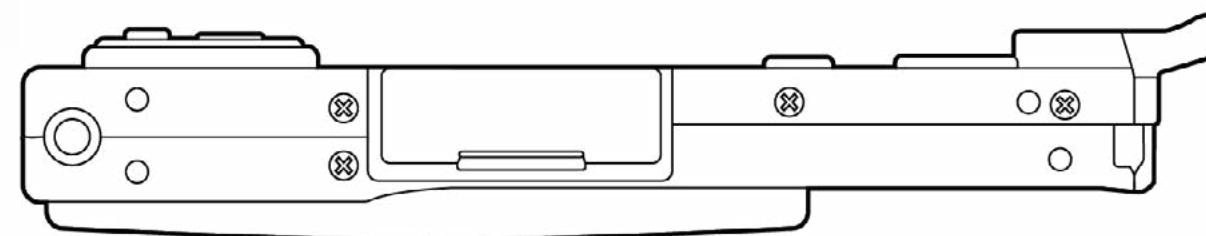
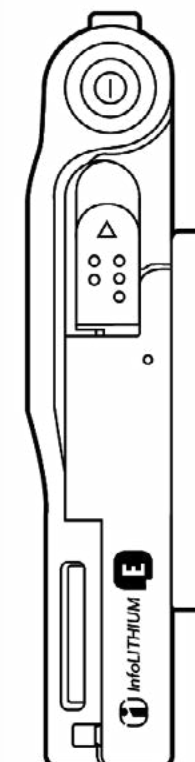
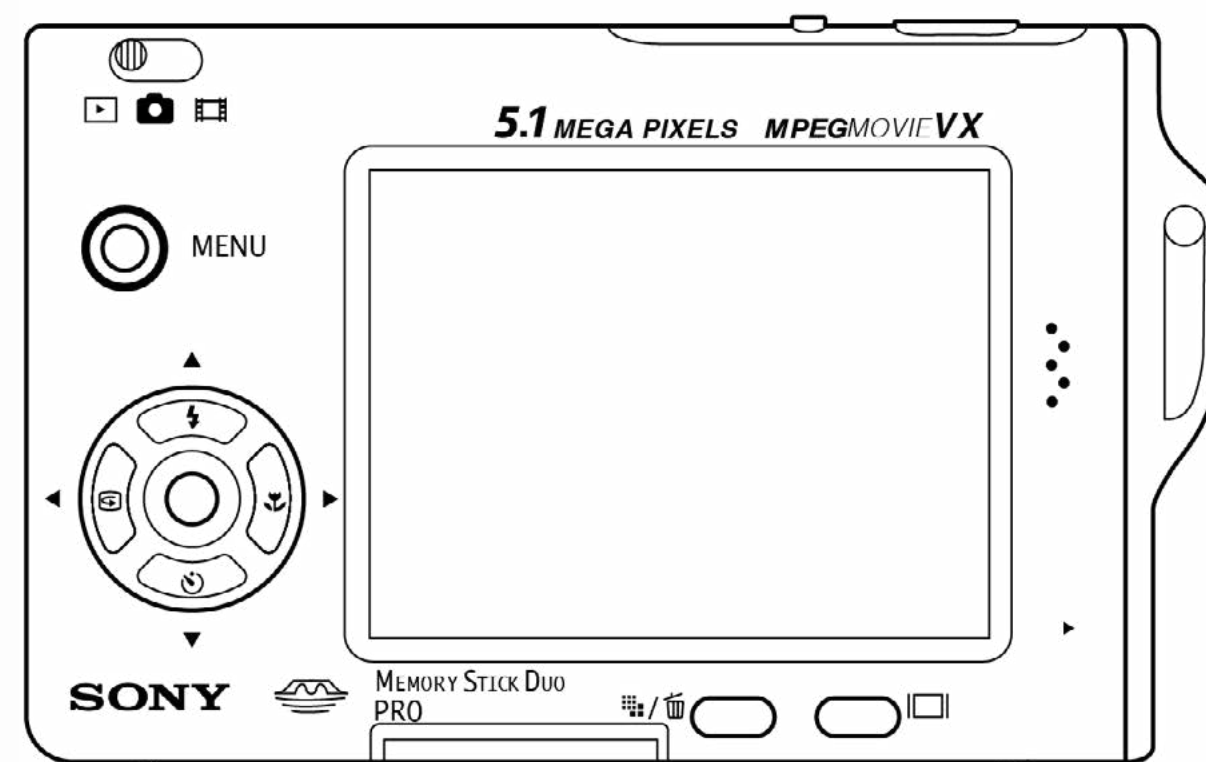
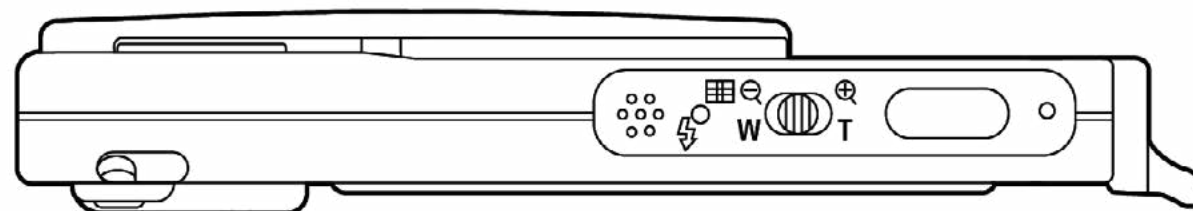
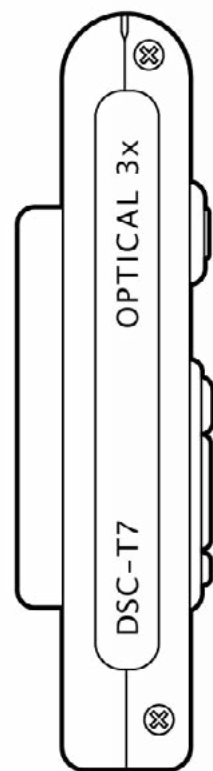
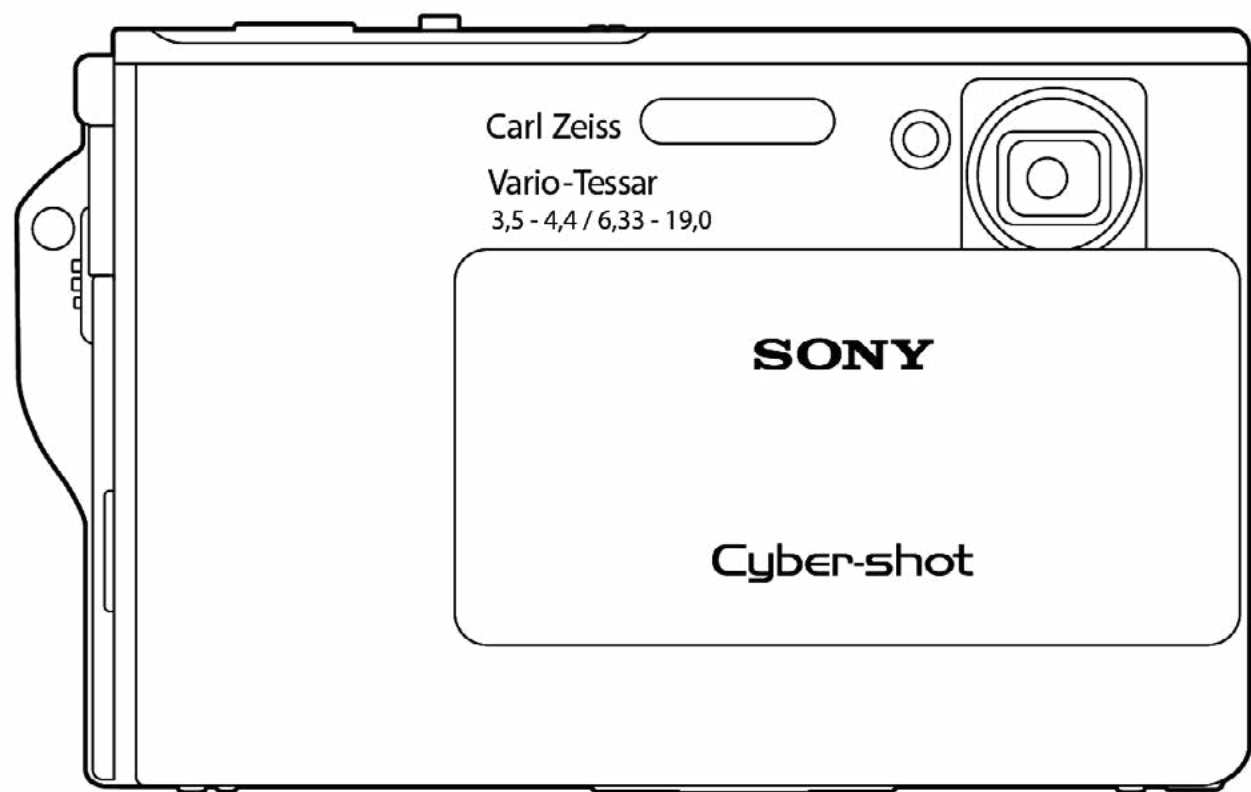

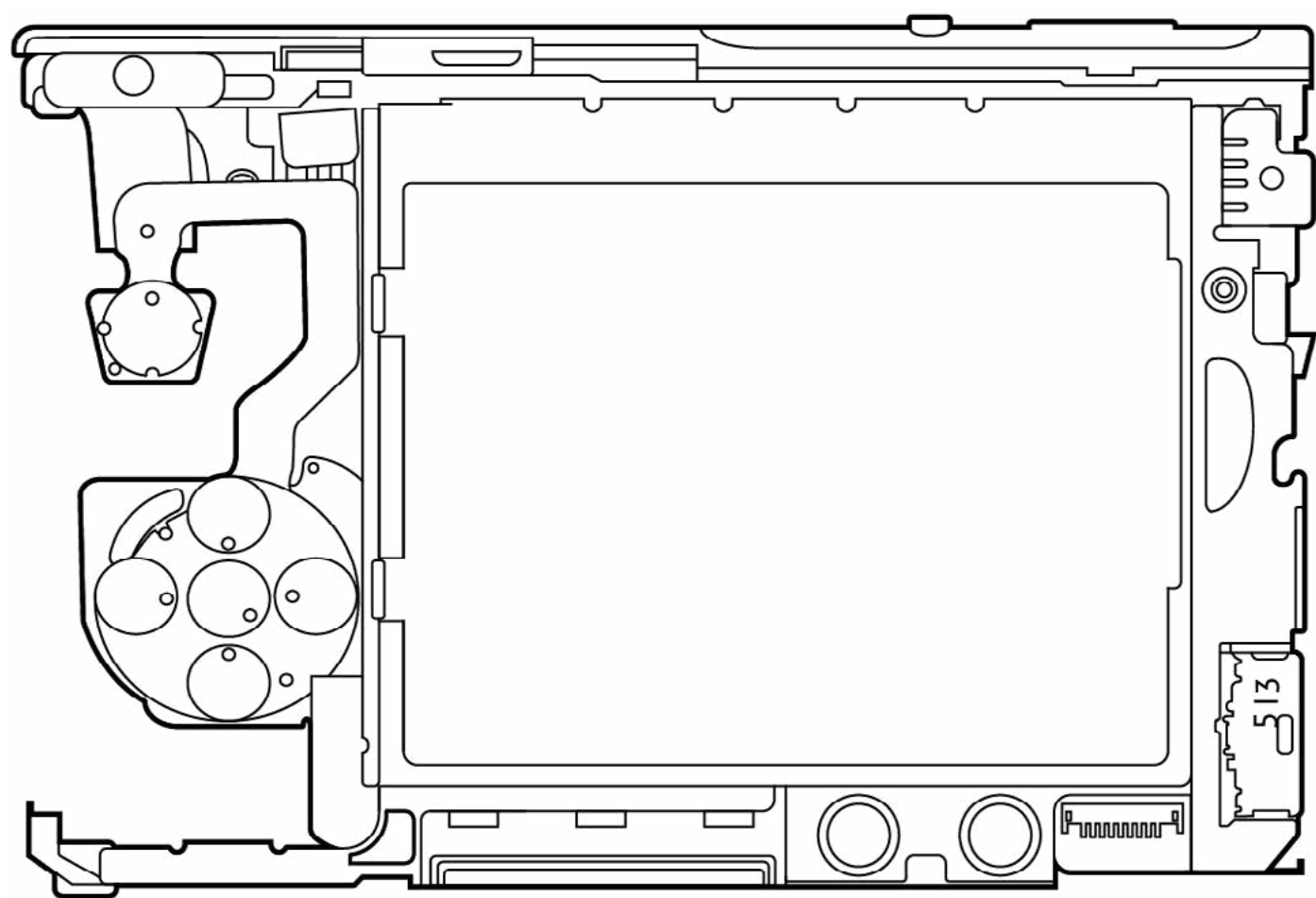
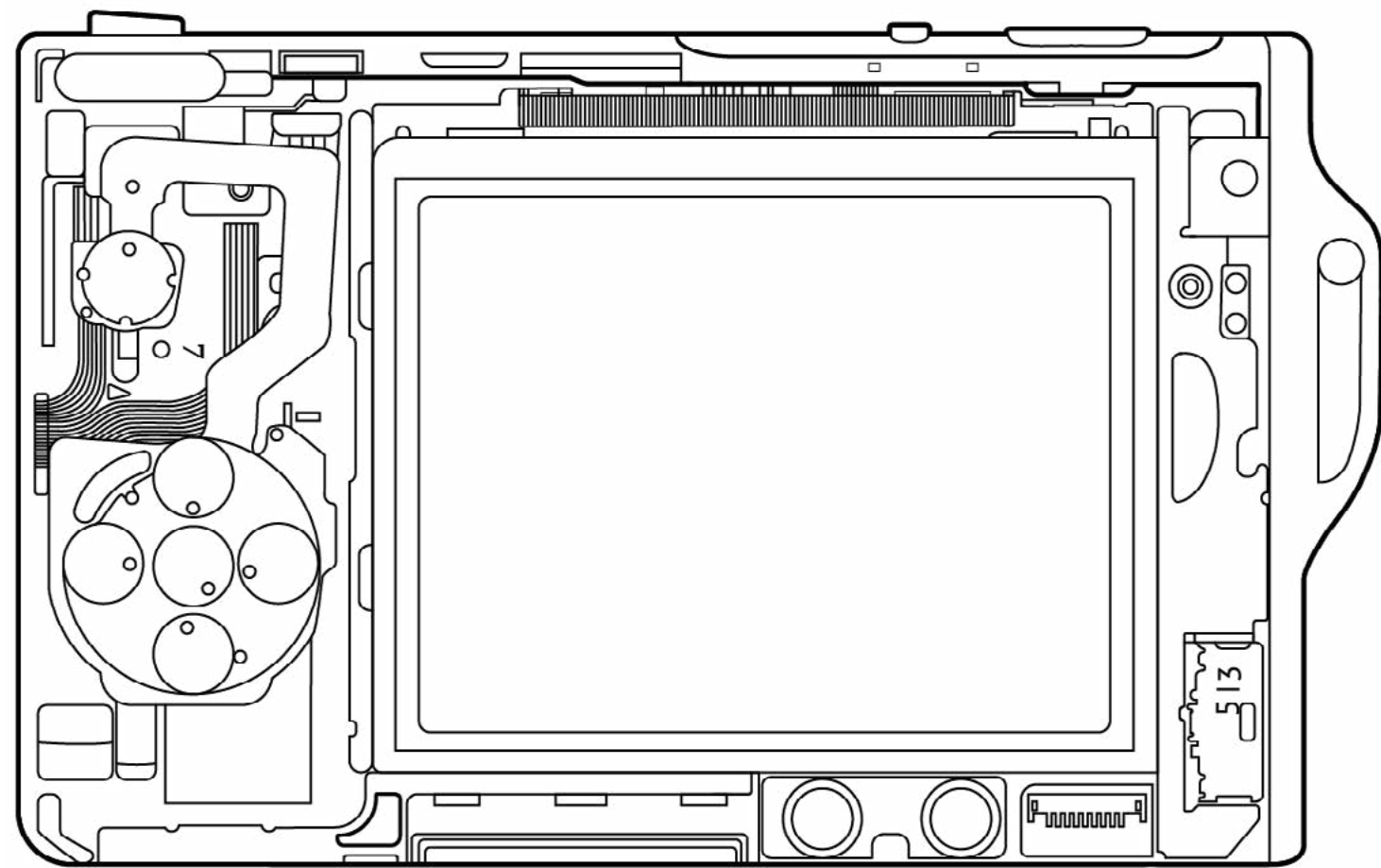
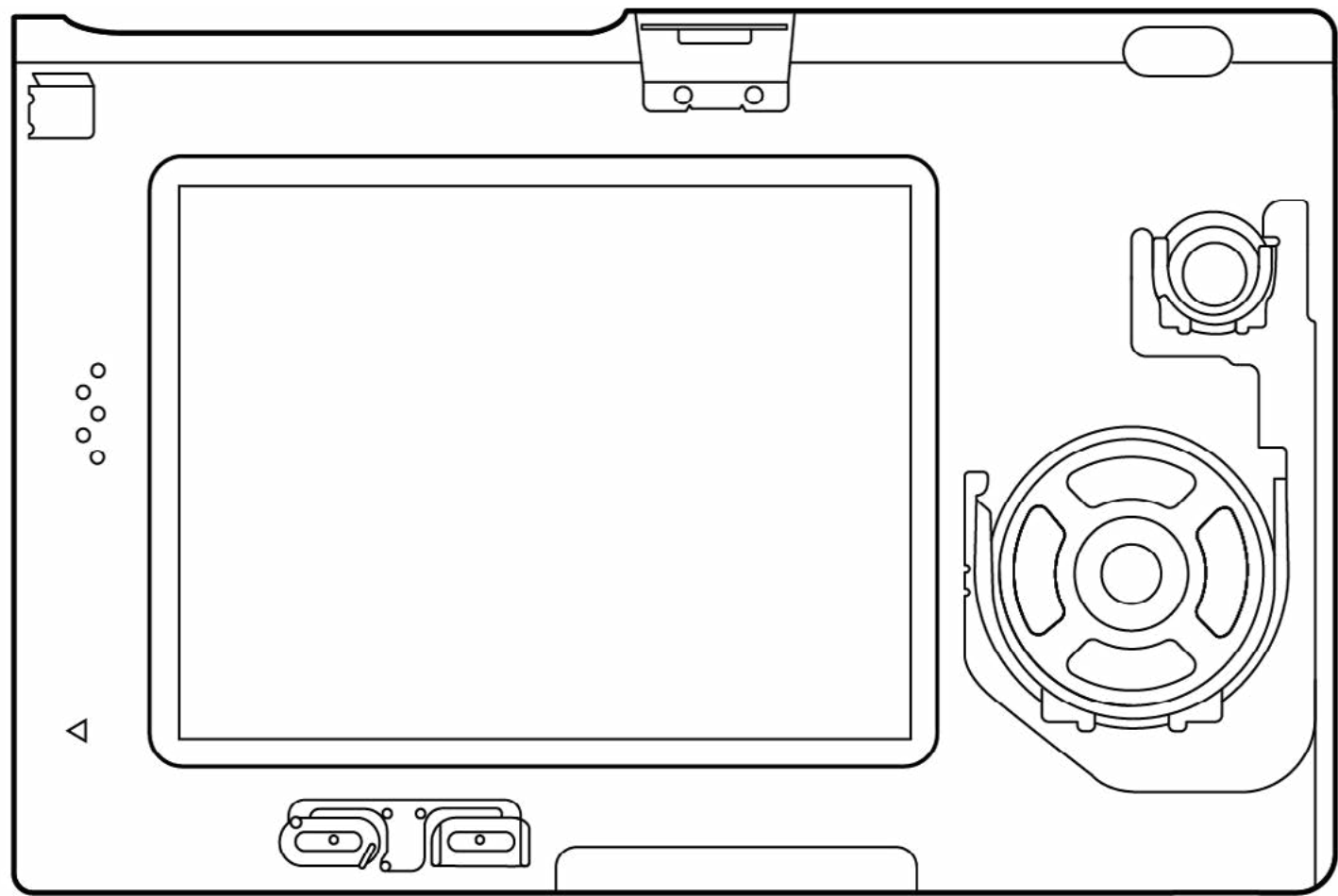

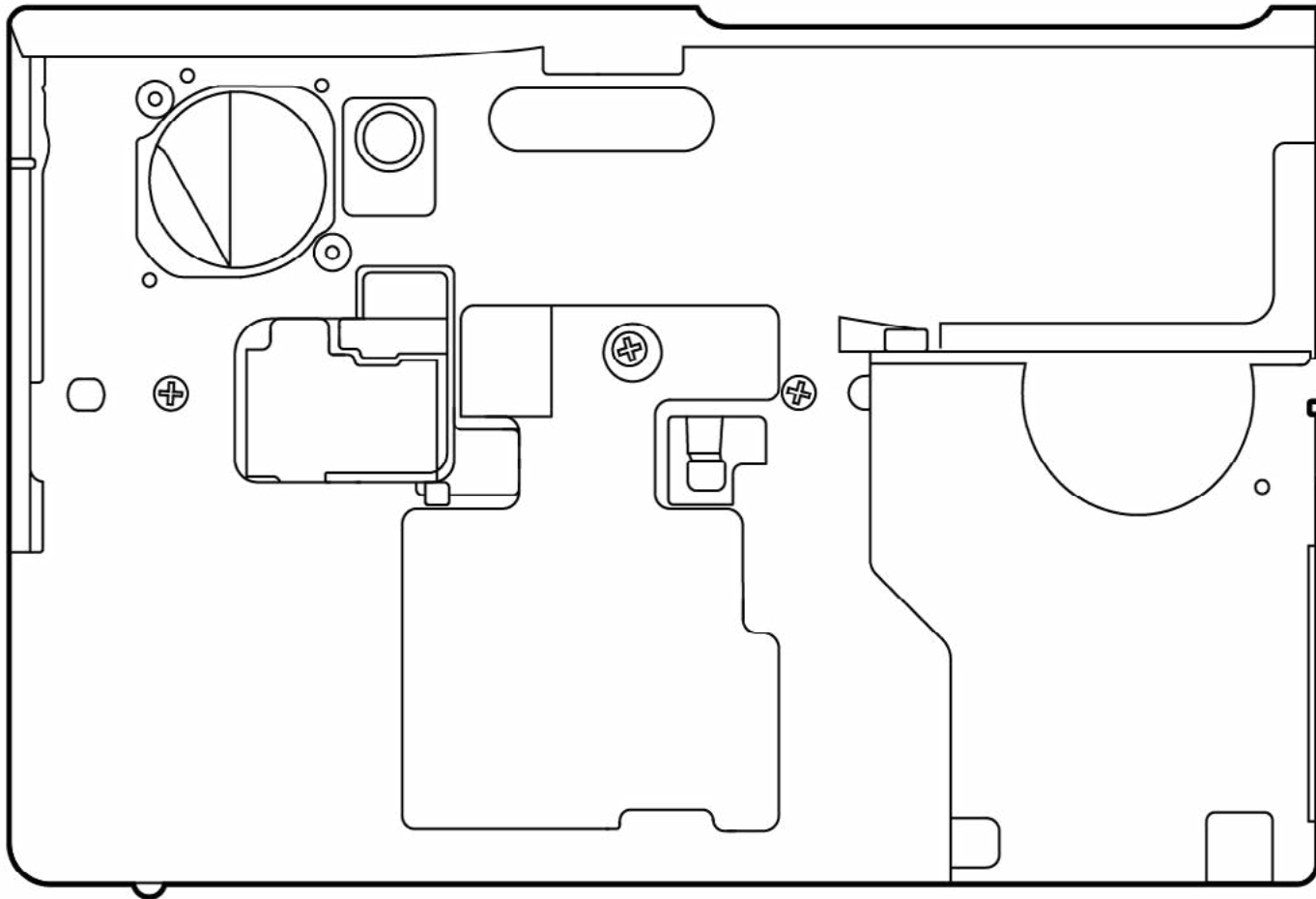
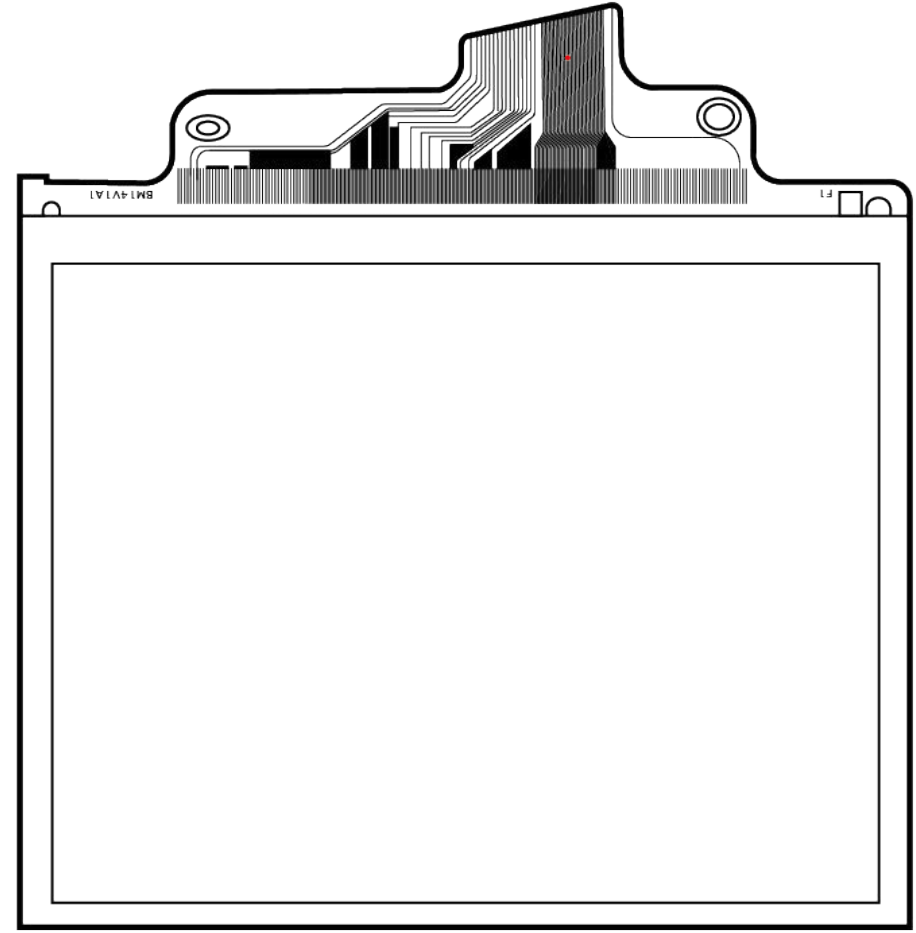
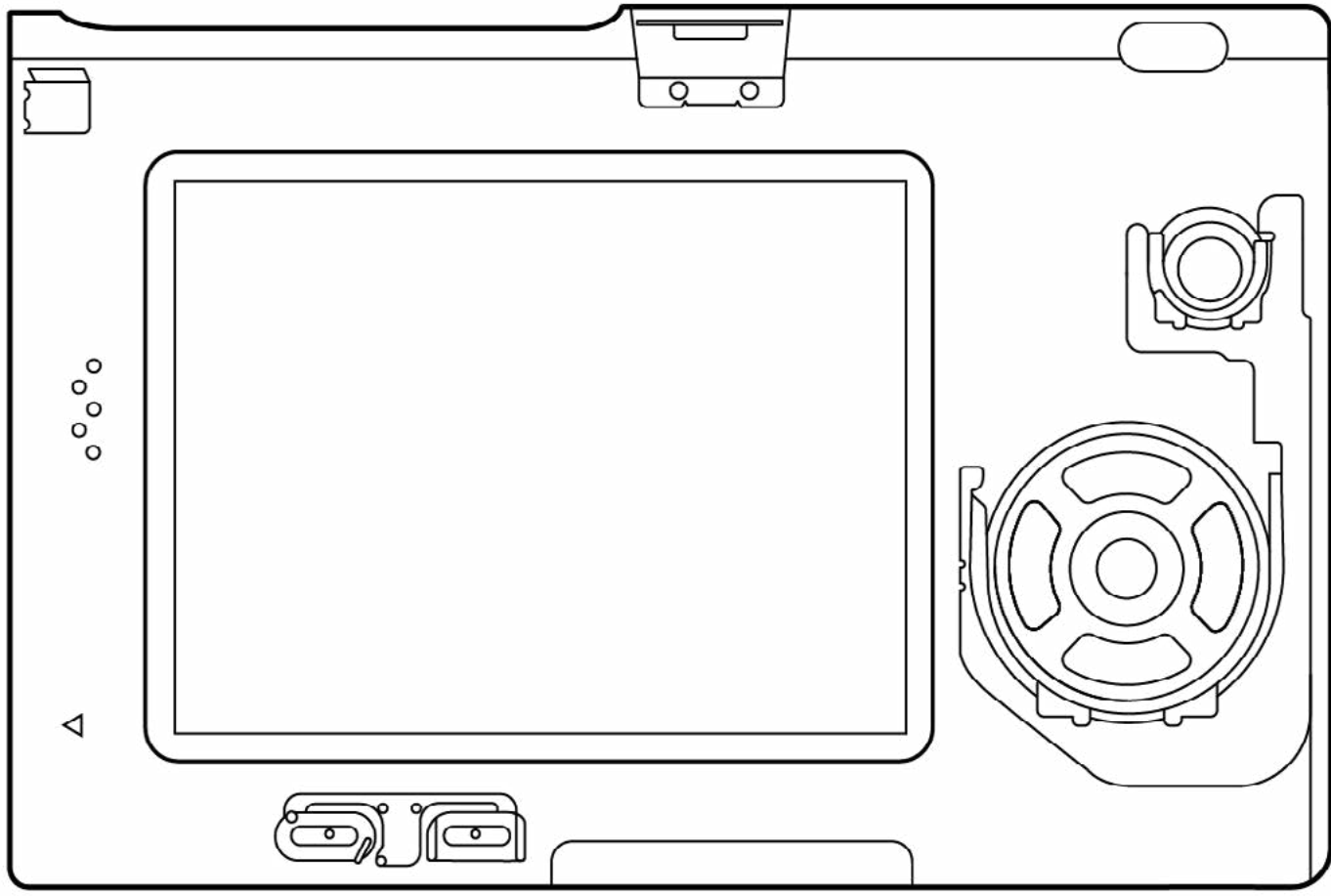

ycuy y
eor dinm

bcdb pore
niu s

kdopin

qpdhnm
coi

drop core

drop core

drop core

drop core

drop

drop

drop core

drop core

0 1 2 3 4 5 6 8 9

a b c d e f g h i j k l m

n o p q r s t u v w x y z

ä ö ü . - , @ ®

Stressful Mornings

Illustration, Vektor

November 2020



Die Aufgabe war es den Sound eines Gerätes mithilfe von Sampling aufzunehmen und ein dazu passendes Plattencover zu gestalten. Meine Wahl fiel auf einen alten Kinderwecker. Ich zerlegte diesen in seine Einzelteile und aus den Klängen, welche diese Teile von sich gaben, entstand mein Sound « Early Mornings ». Anschliessend gestaltete ich zwei Versionen eines Plattencovers. Dazu vektorisierte ich die Einzelteile des Weckers in Illustrator und konzentrierte mich bei der Gestaltung auf die Tonhöhen und Tonlängen der eingesetzten Teile.



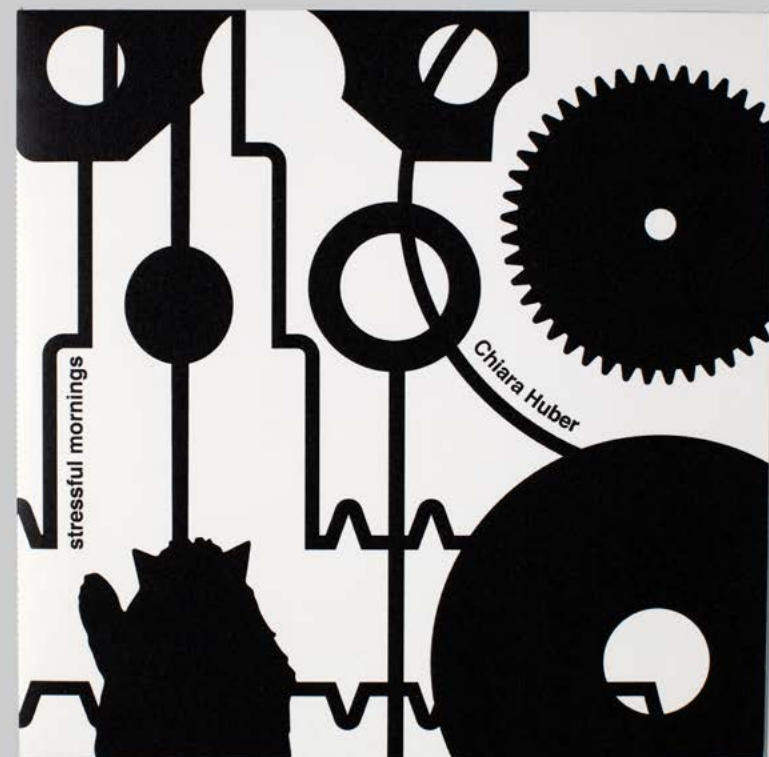
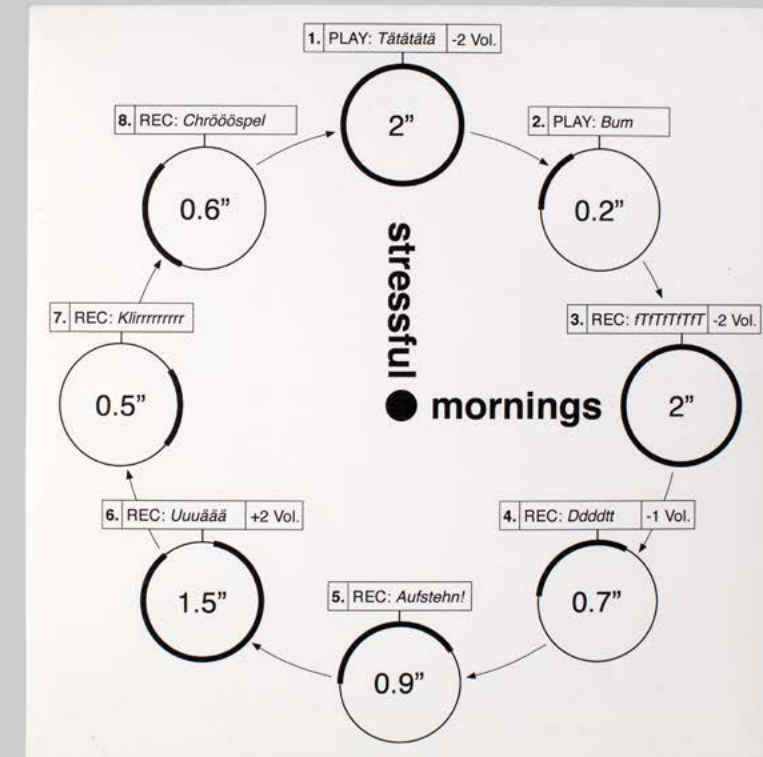



Chiara Huber
Grafikerin Luzern
Mai 2004
huberchiara@gmx.ch
chiarahuber.ch

Programme
Indesign: sehr gut
Photoshop: gut
Illustrator: gut
Adobe XD: basic
Adobe Lightroom: gut
Glyphs: basic
Html, CSS: basic

Sprachen
Deutsch: sehr gut
Englisch: gut
Französisch: gut

Ich bin Chiara Huber, 17 Jahre alt und befinde mich zurzeit im dritten Ausbildungsjahr zur Grafikerin EFZ an der Fachklasse Grafik Luzern. Meine Interessen liegen vor allem im Bereich Layout, Typografie, Font-Design, sowie auch Fotografie. Ich bin eine sehr strukturierte und organisierte Person und liebe es neue gestalterische Konzepte auszutüfteln. Ich interessiere mich sehr für die Arbeit im Detail und bin immer wieder fasziniert, welche grosse Wirkung auch die kleinsten Eingriffe erzielen können. In meiner Freizeit ist das Backen meine Leidenschaft, bei welcher ich meiner Kreativität freien Lauf lassen kann. Auch erfüllt es mich gemeinsame Zeit mit meiner Familie und meinen Freunden zu verbringen.