

**Portfolio**  
Chiara Huber  
2021

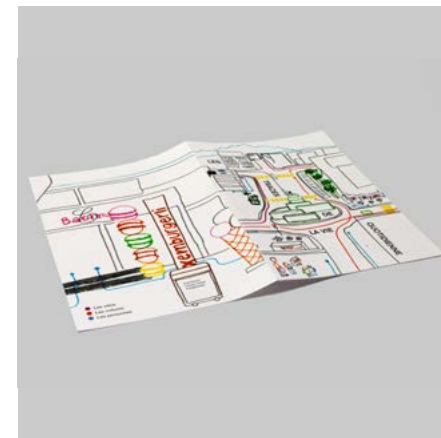

012345689  
abcdefghijklmnop  
nopqrstuvwxyz  
äöü-.,!@®

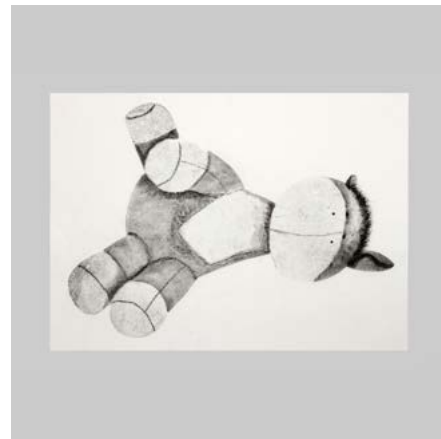

abc c d e f f g g  
g h h i j k l m n o  
p q q r r s t u v  
w x y z f t e g s



<b>Colour study</b> Colour	<b>33</b>	<b>63</b>	<b>Anamorphosis</b> Photography, Film, Typography	<b>22</b>	<b>Shelf by Shelf</b> Layout, Editorial, Drawing	<b>75</b>	<b>Chiara Huber</b> Graphic Designer
		<b>3</b>	<b>Streamers</b> Colour, Screen printing, Illustration				
<b>66</b>	<b>Lens font</b> Illustration, Font Design			<b>43</b>	<b>The traces of every- day life</b> Layout, Photography, Drawing		
		<b>17</b>	<b>Memories</b> Drawing, Printmaking			<b>54</b>	<b>The Queens are the strongest</b> Layout, Drawing
		<b>49</b>	<b>Calligraphy</b> Typography, Calligraphy			<b>39</b>	<b>Master's graduation concerts</b> Typography, Illustration
<b>Look away</b> Photography, Typo- graphy	<b>8</b>			<b>72</b>	<b>Stressful Mornings</b> Illustration, Vector		



## Streamers

Illustration, Colour, Screen printing  
January 2021

Our assignment was to design correspondence cards for the “Fachklasse Grafik Lucerne”. Postcards that can be sent for birthdays or other special occasions. I automatically associate festive occasions with coloured streamers. I used the paper scraps left over from cutting my screen - printed postcards and distorted them using a scanner. The result was a series of scans that I then layered and assembled into a postcard. The card was offset printed in three colours.





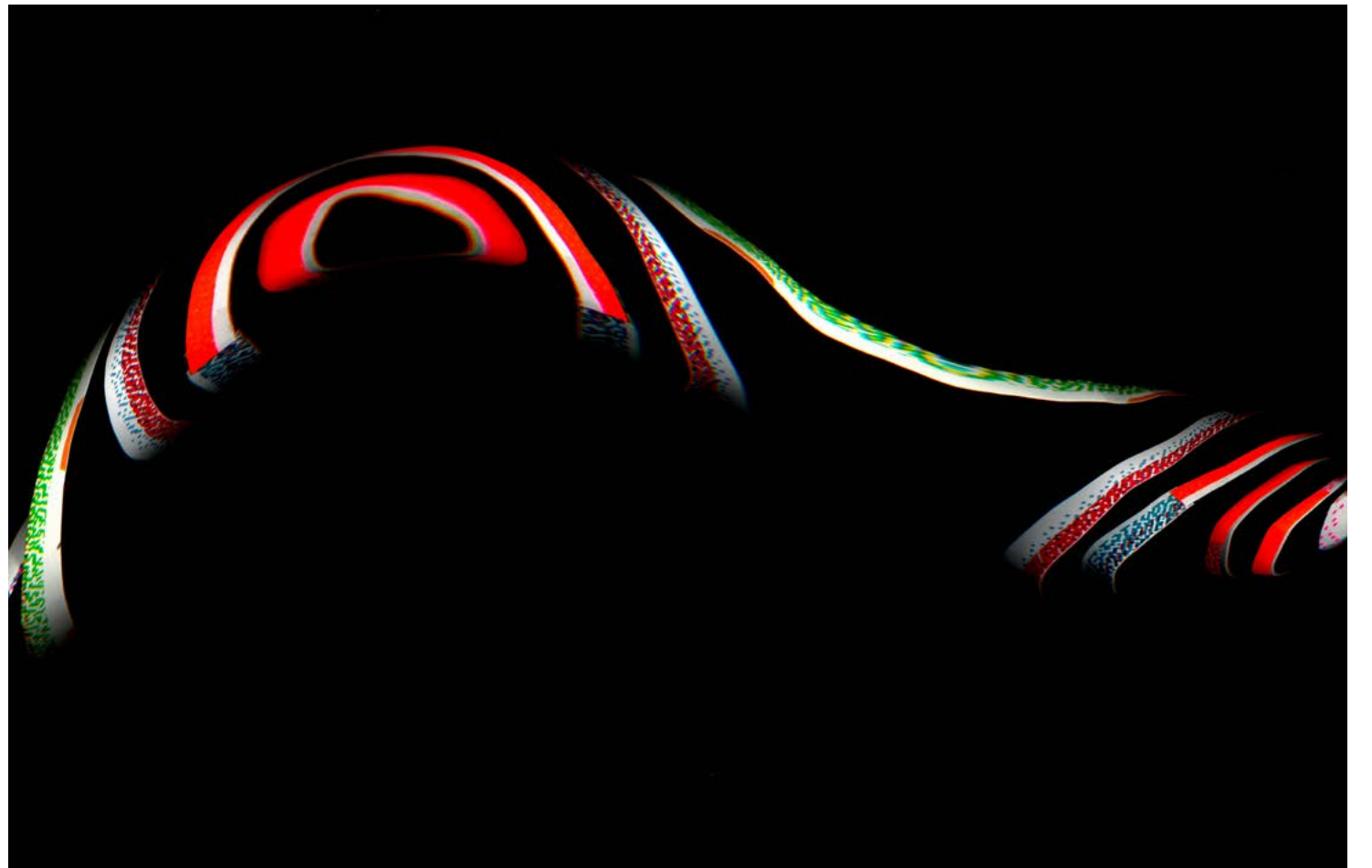
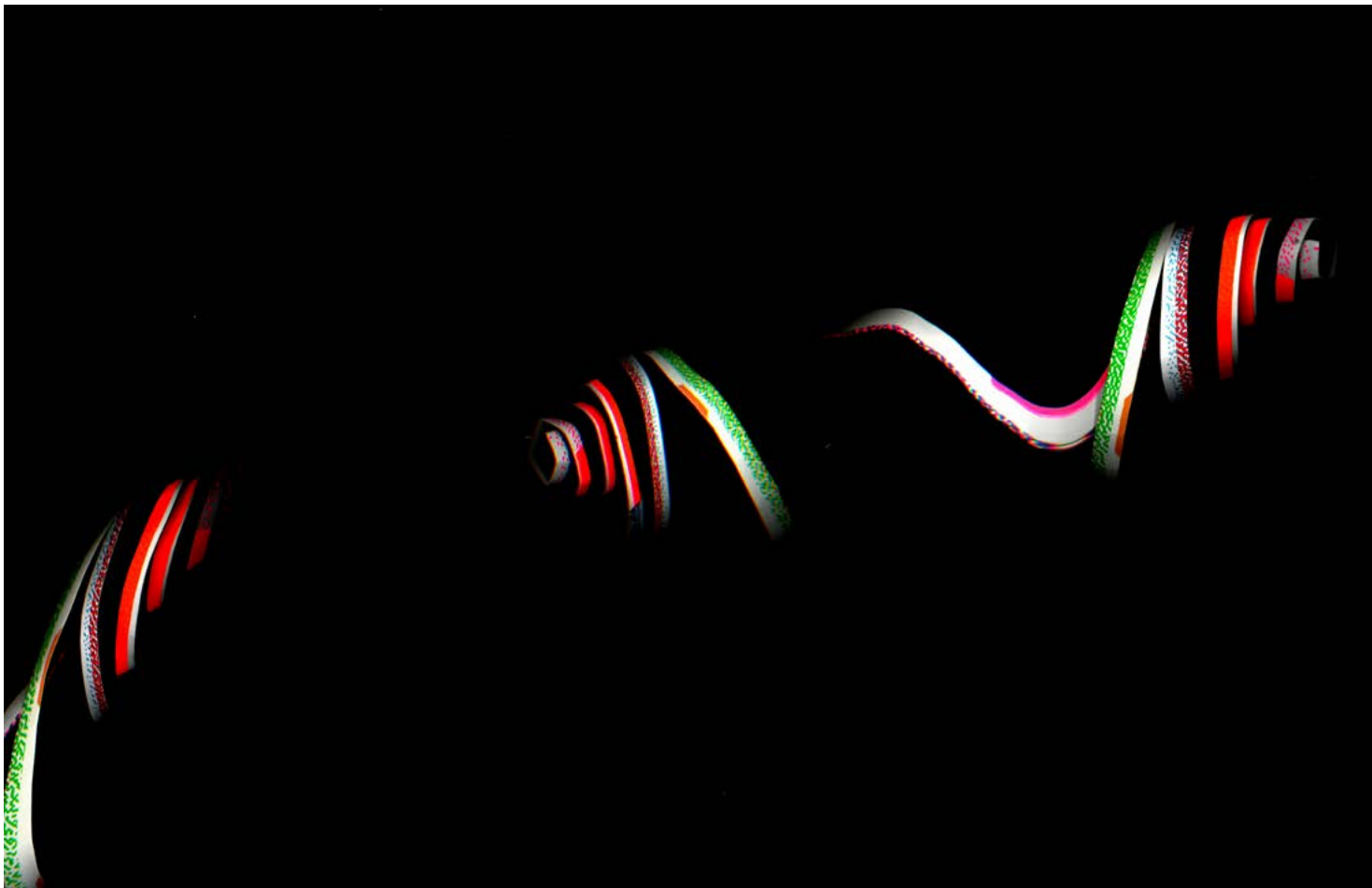
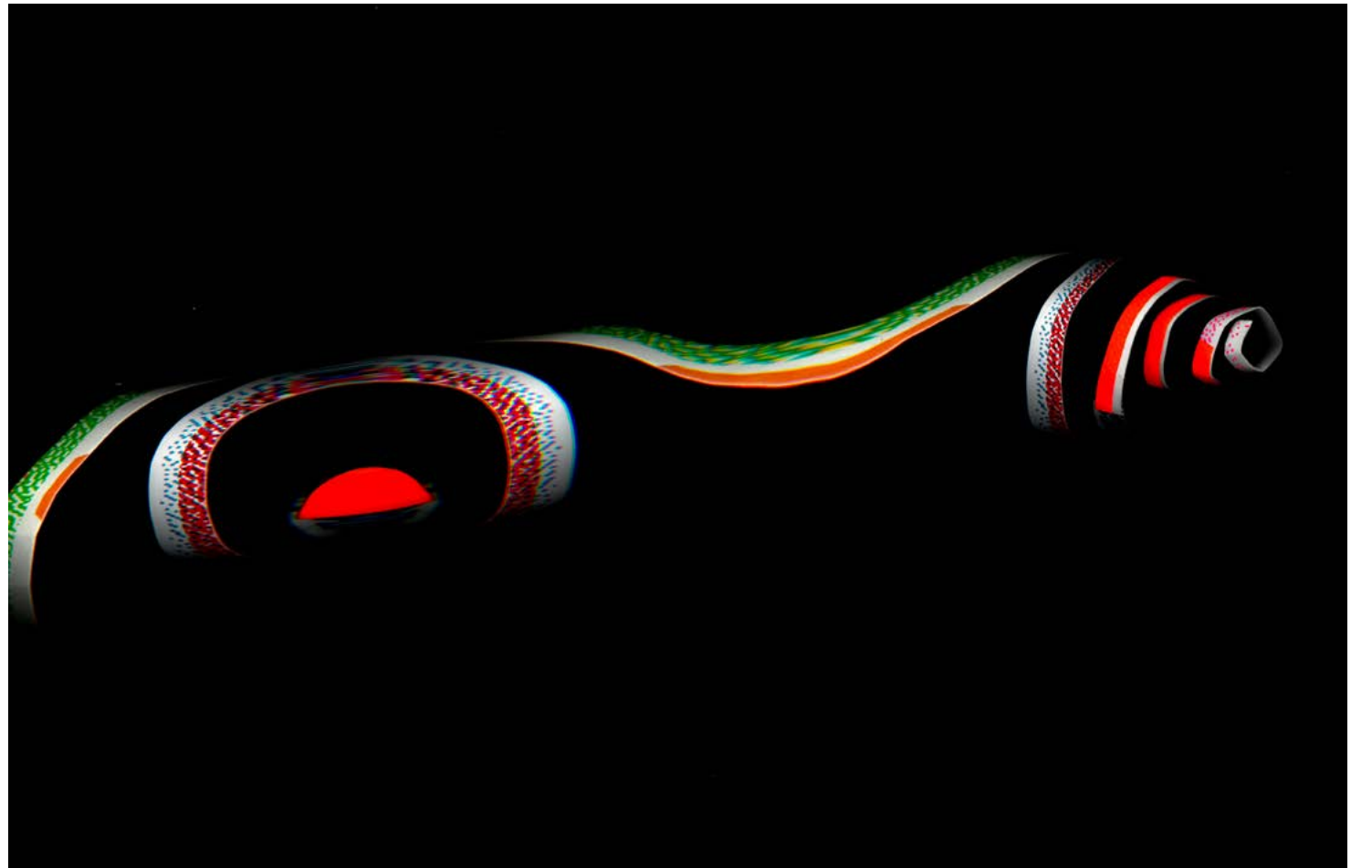
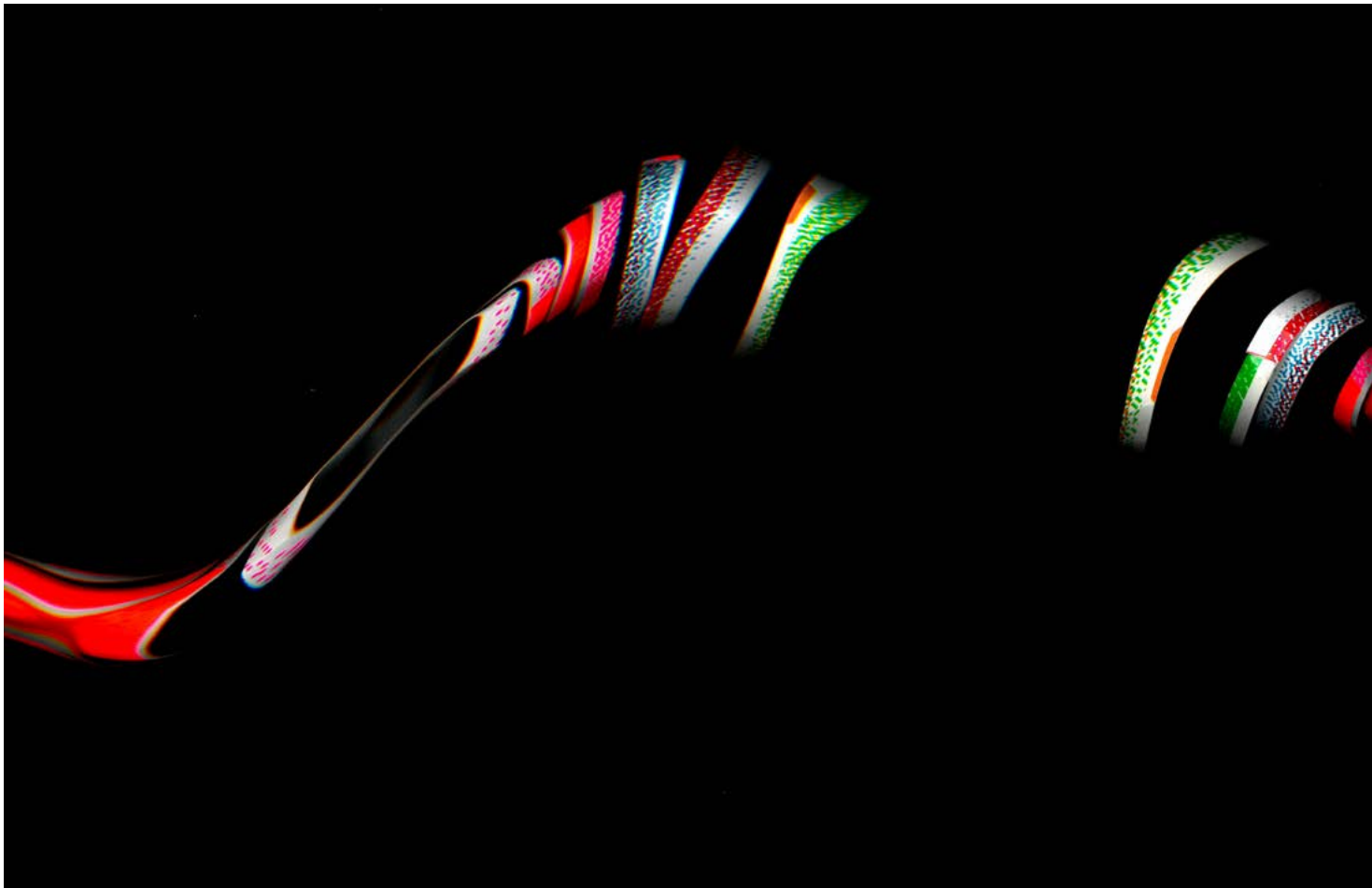





## Look away

Photography, Typography

March 2021

Respect. A big and important topic. What does respect mean in our society? I explored the issue of “looking the other way” in bullying through photography. More than ever, bullying is a big issue today. The statement: “To look away is to participate” inspired me. The great silence around the issue of bullying is one of the biggest obstacles to stopping bullying in a targeted way. My photographs show the exclusion, the insecurity, the lack of understanding, the isolation and the looking away. In an analogue process, I then designed a newspaper and combined the photo series with typography – to get everyone to “look”.

HINSEHEN

WZHDV

Gestaltung: Chara Kubler - Wegmannen - Ein Beitrag im Rahmen des Projektes Fotografix zum Thema «Blickpunkt in der Gesellschaft» - Fachklasse Grafik, Luzern FMZ, 2001 - Text: Norbert von Tiggelen

N

W





Keine Zeit für liebe Worte, für ein wenig Mitgefühl.

In den Herzen stilles Schweigen,  
Lebenslust meist fad und kühl.



Keine Zeit für Diskussionen, es lebe hoch das Vorurteil.

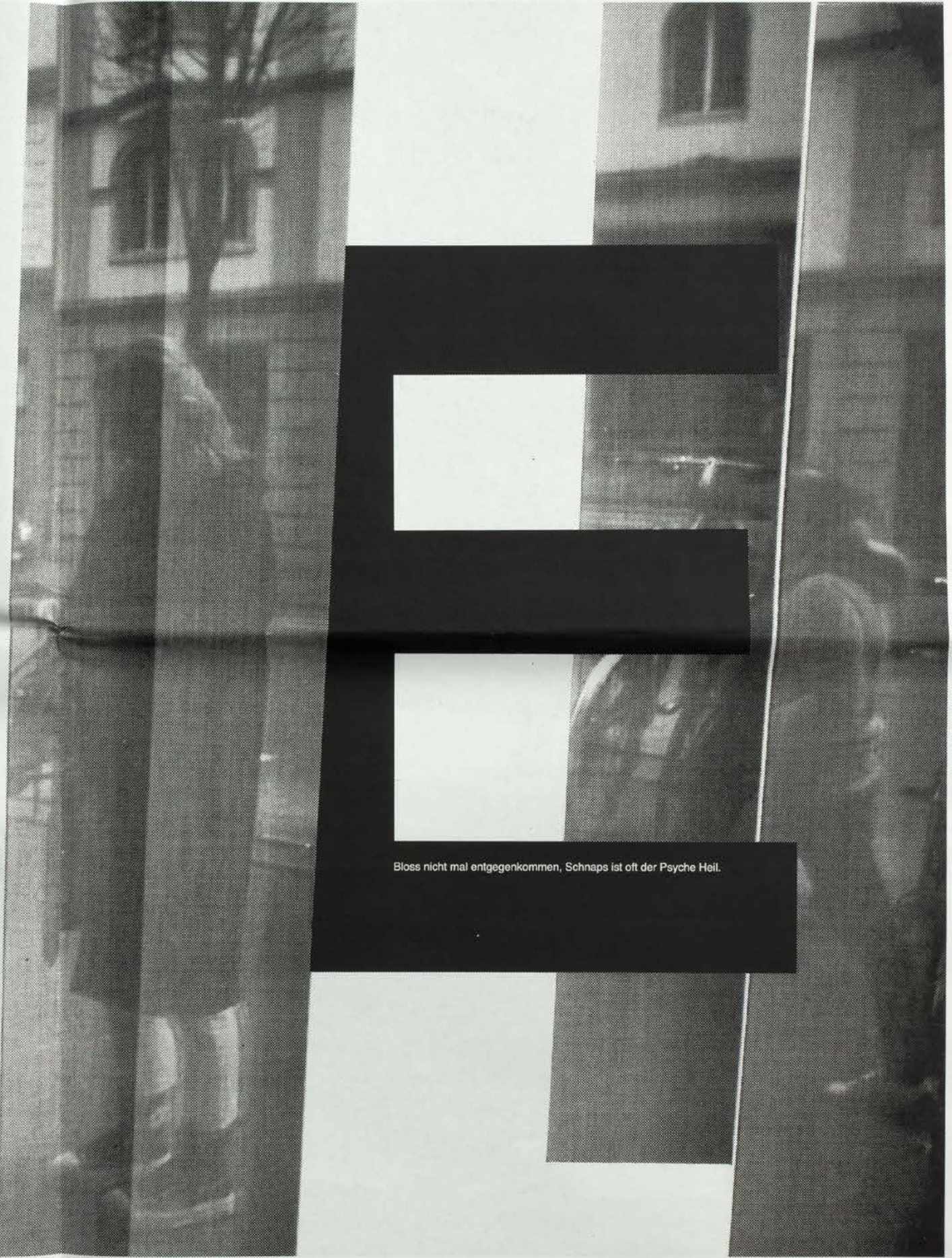

Bloss nicht mal entgegenkommen, Schnaps ist oft der Psyche Heil.

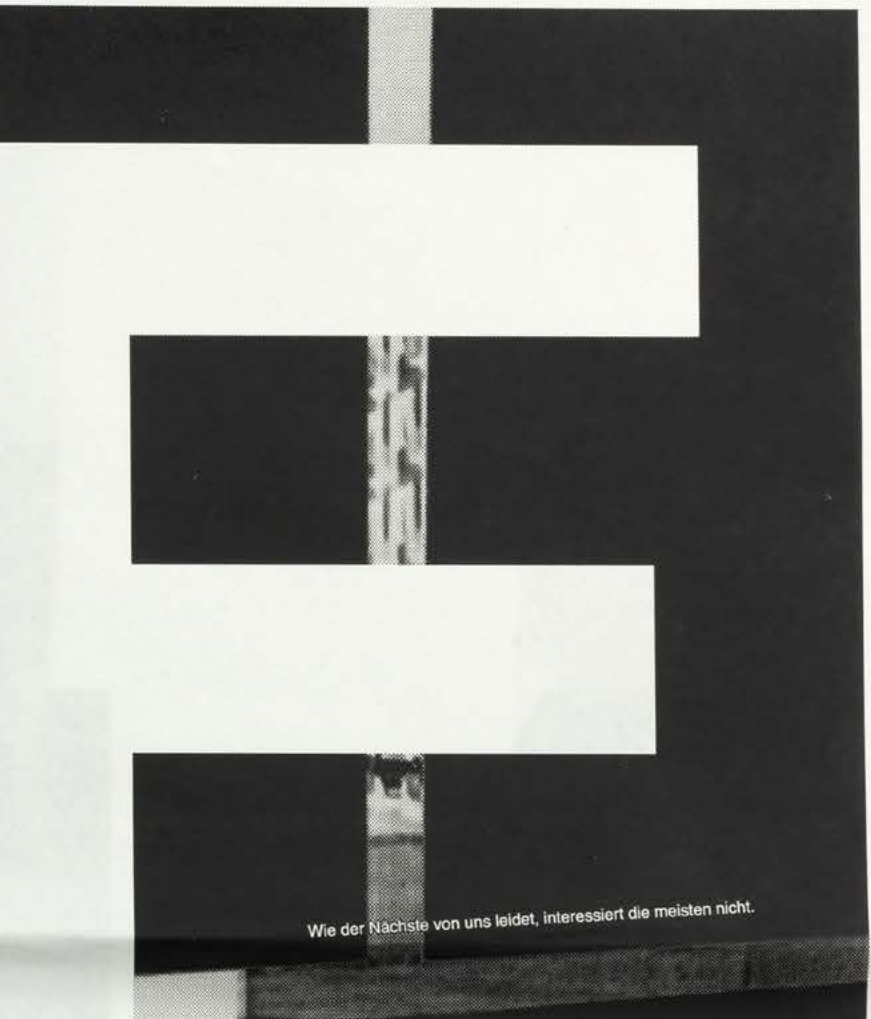
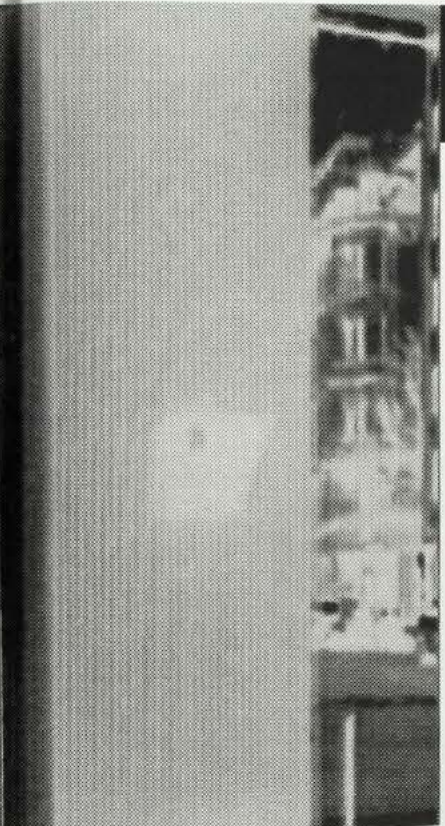

Wie der Nächste von uns leidet, interessiert die meisten nicht.

Keine Zeit für klare Blicke, in den Augen starre Sicht.

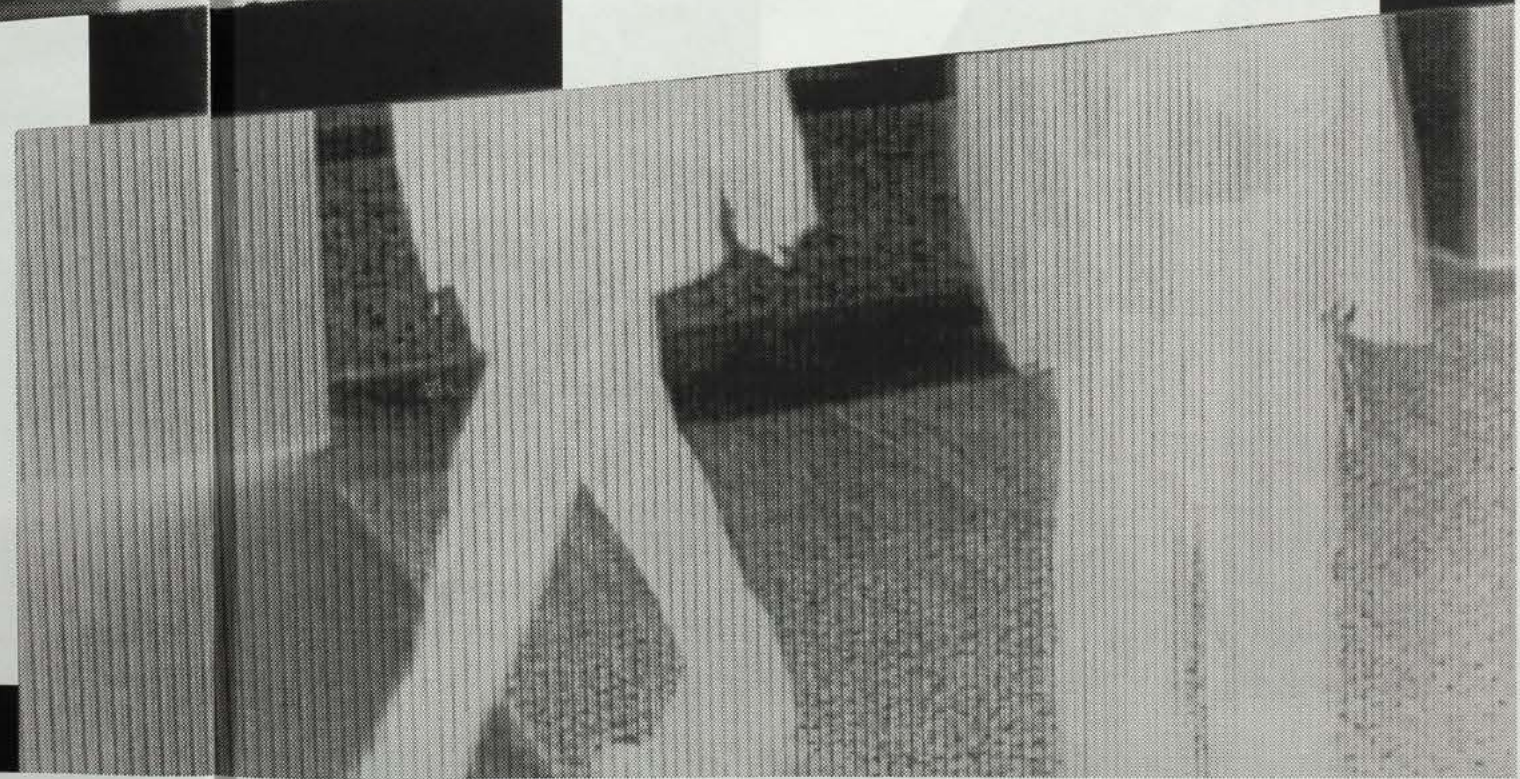

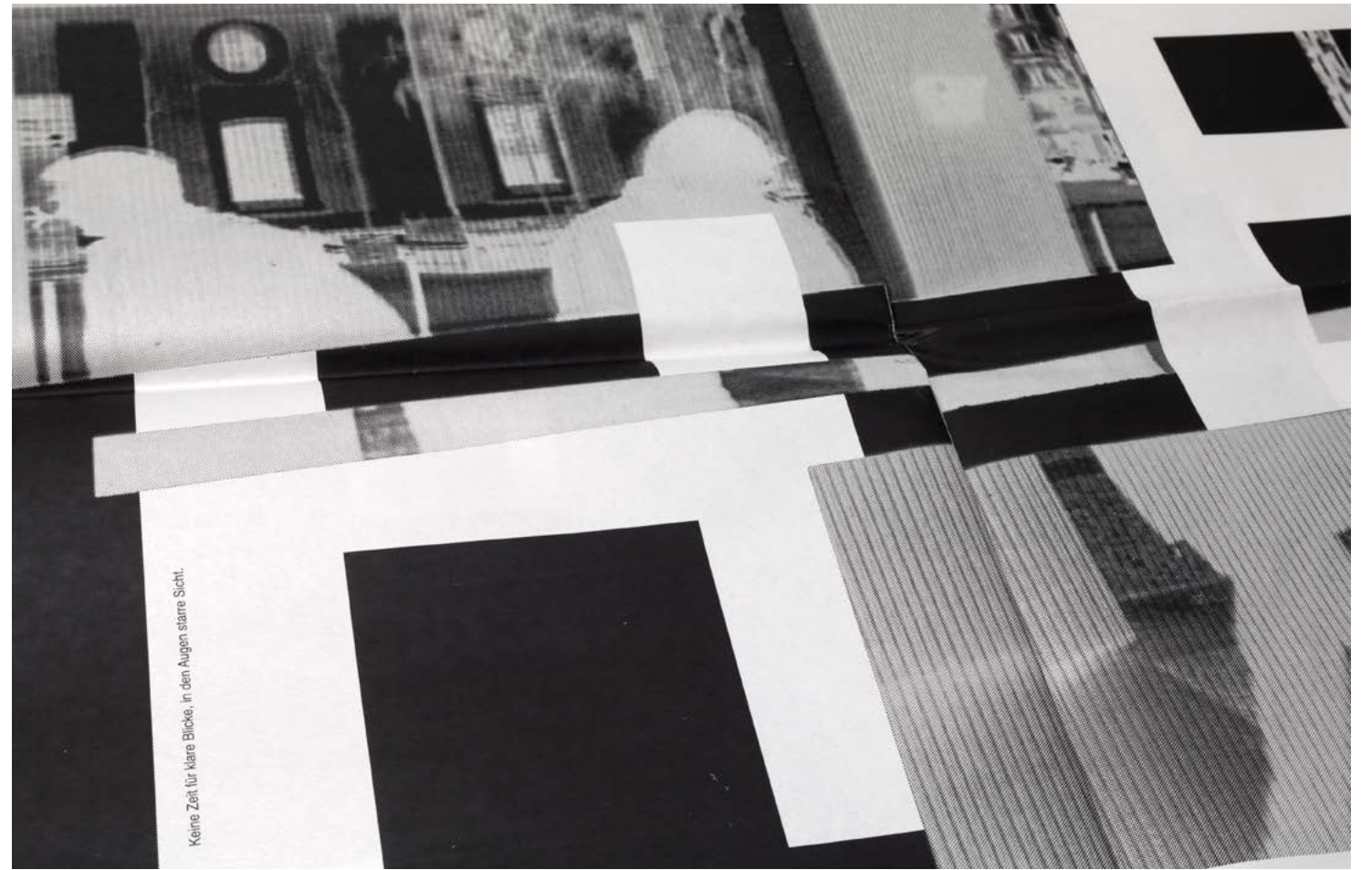

# HINSEHEN

WIRTSCHAFTS

Text: Norbert van Tiggelen

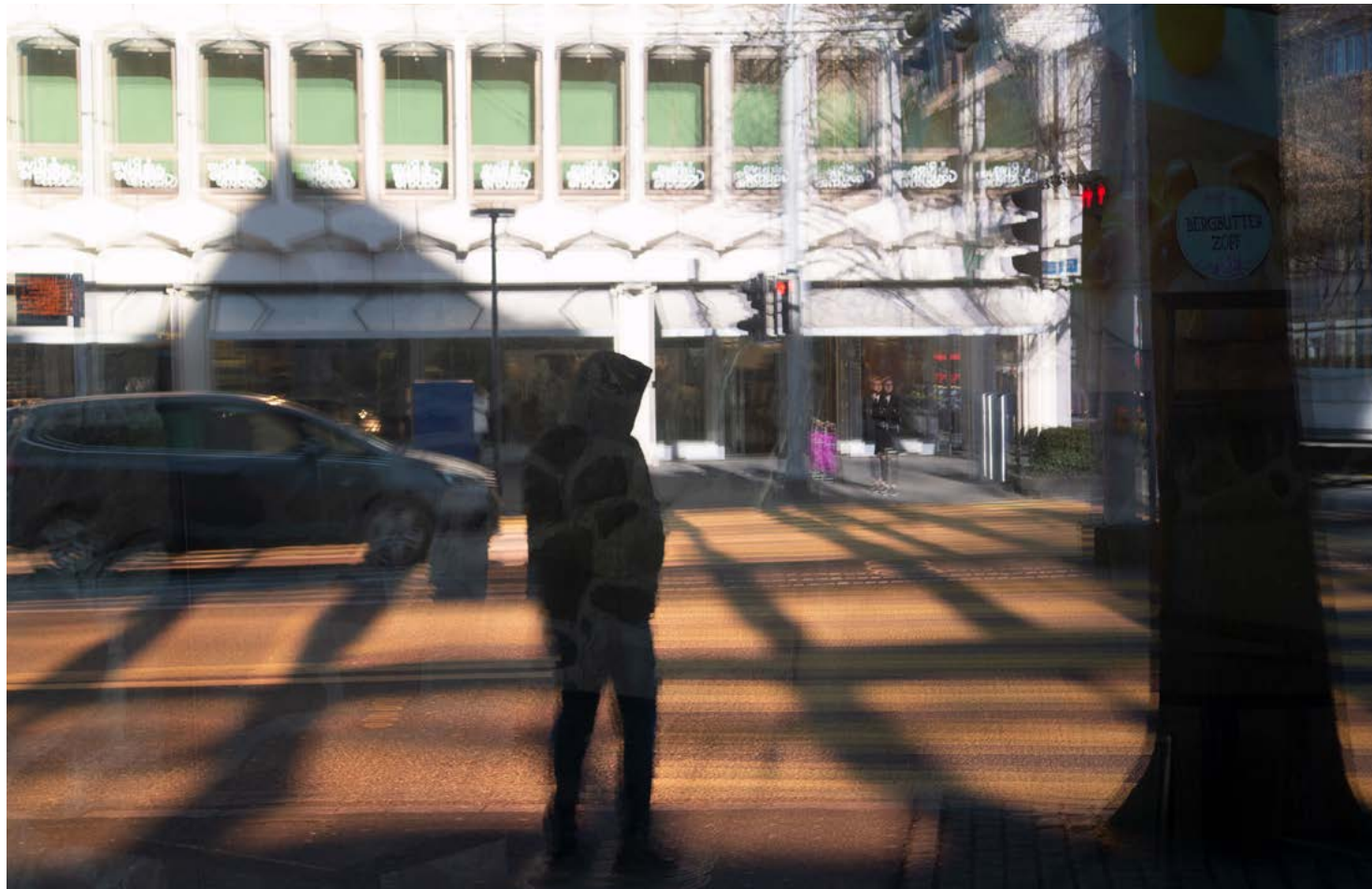





## Memories

Drawing, Printmaking

January 2020

The aim was to portray a self - chosen memento from childhood. I decided on my old cuddly toy, which I examined in a first step in terms of materiality, volume, function, and structures by drawing. I wanted to convey this cuddly, fluffy and sweet donkey to the viewer exactly as I perceived it in my childhood. For the realisation I used the printing technique “monotype” and was mainly concerned with the representation of the structure of the fur. I then added details and refinements with ink.

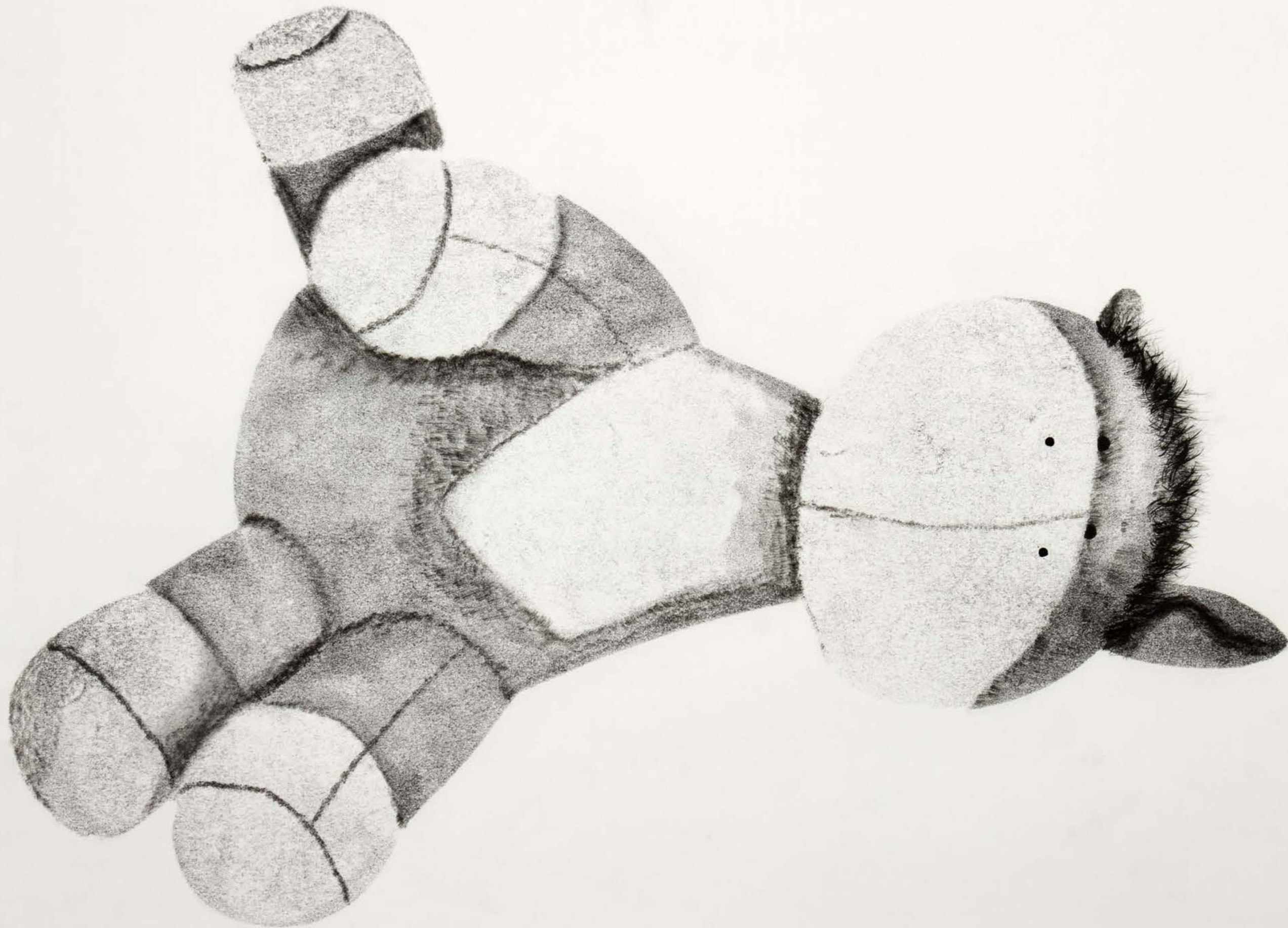

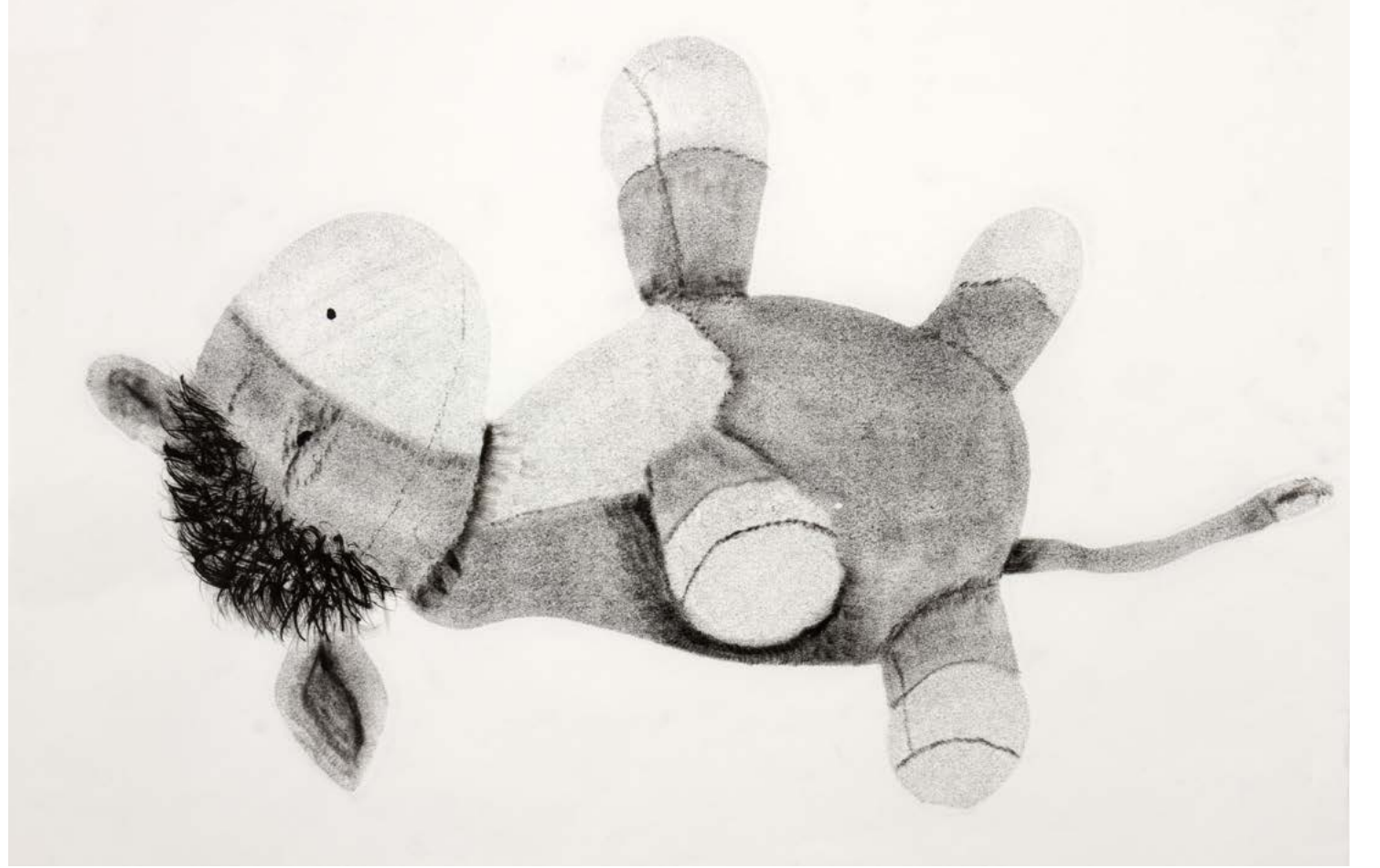
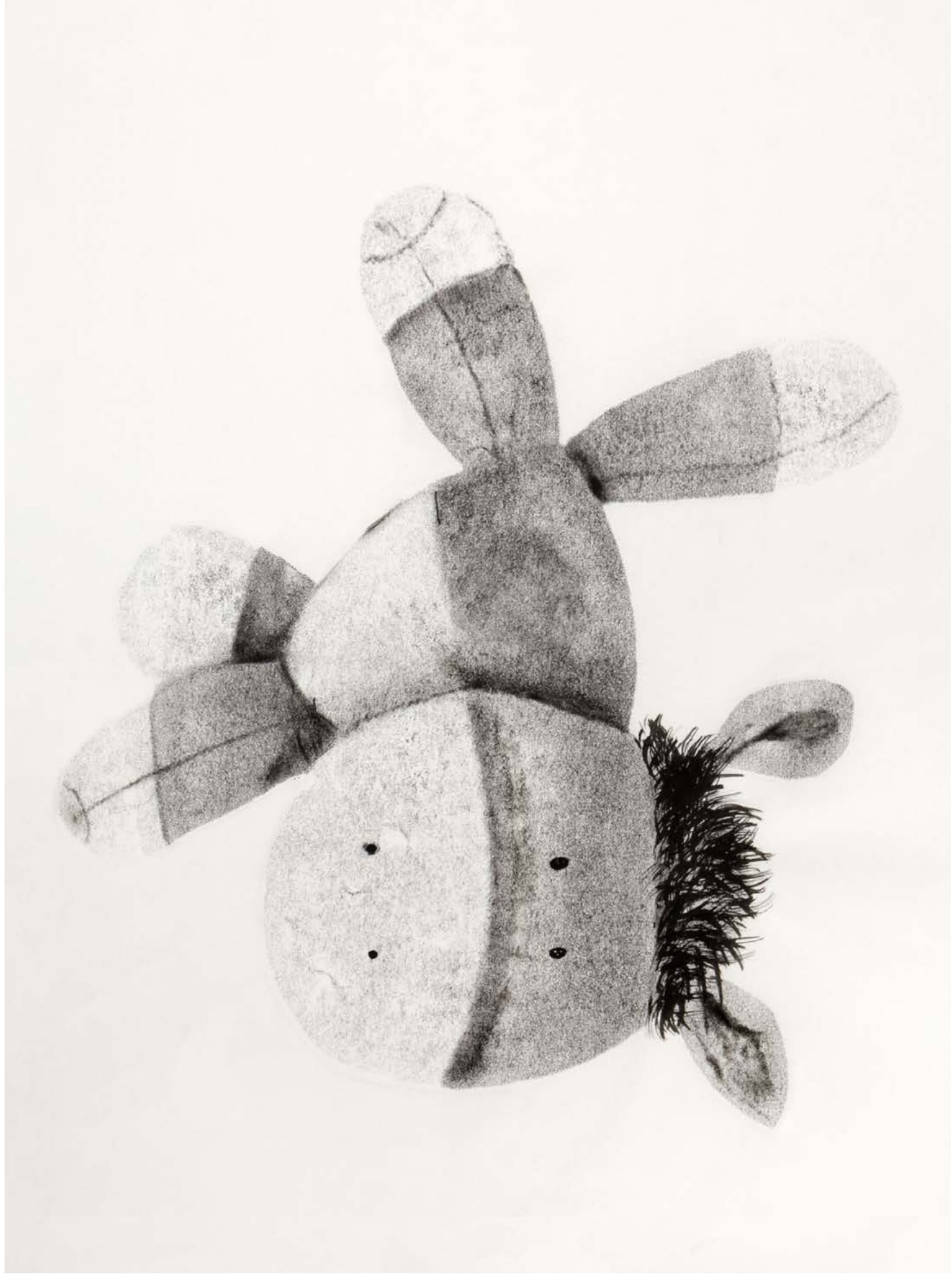



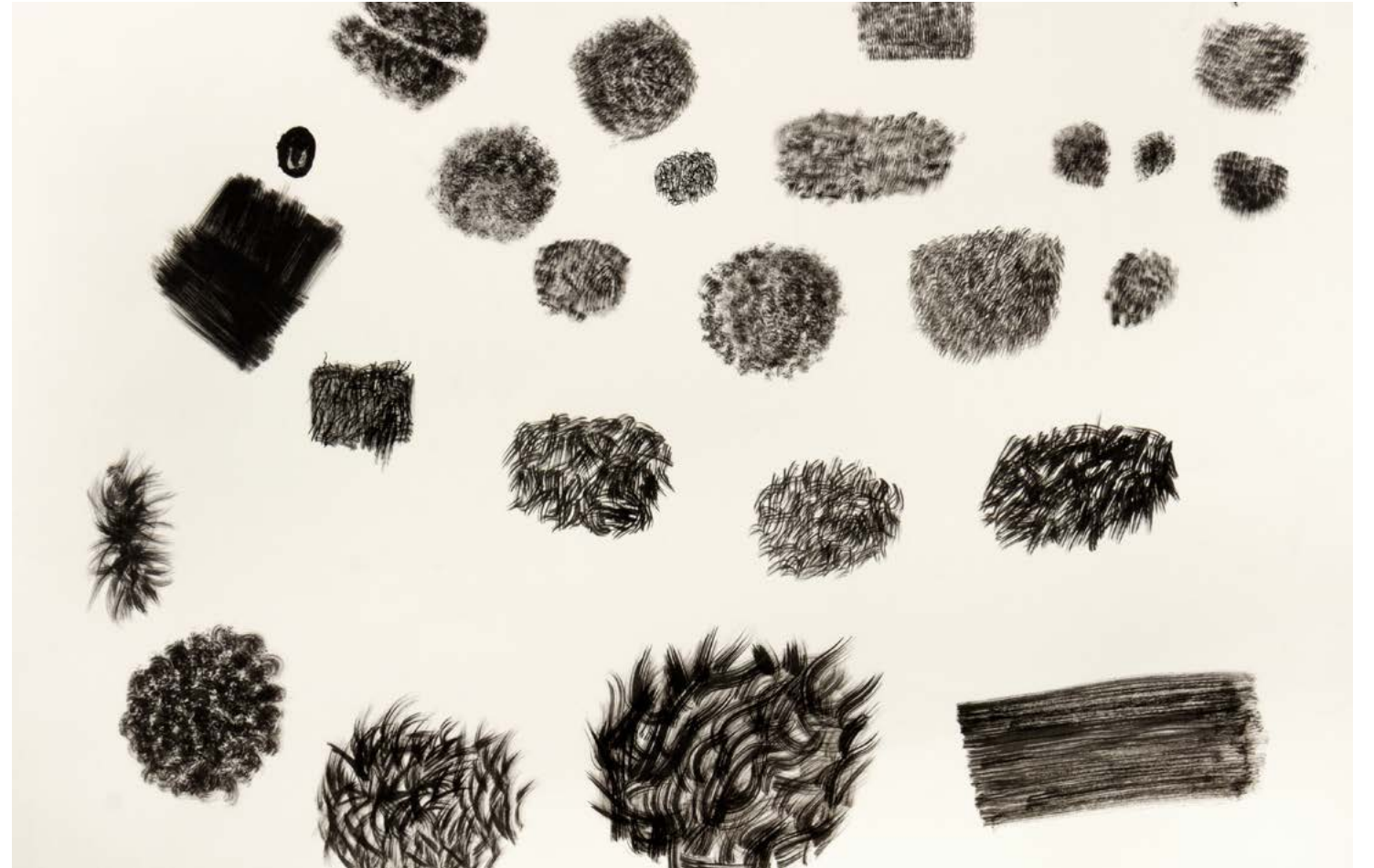
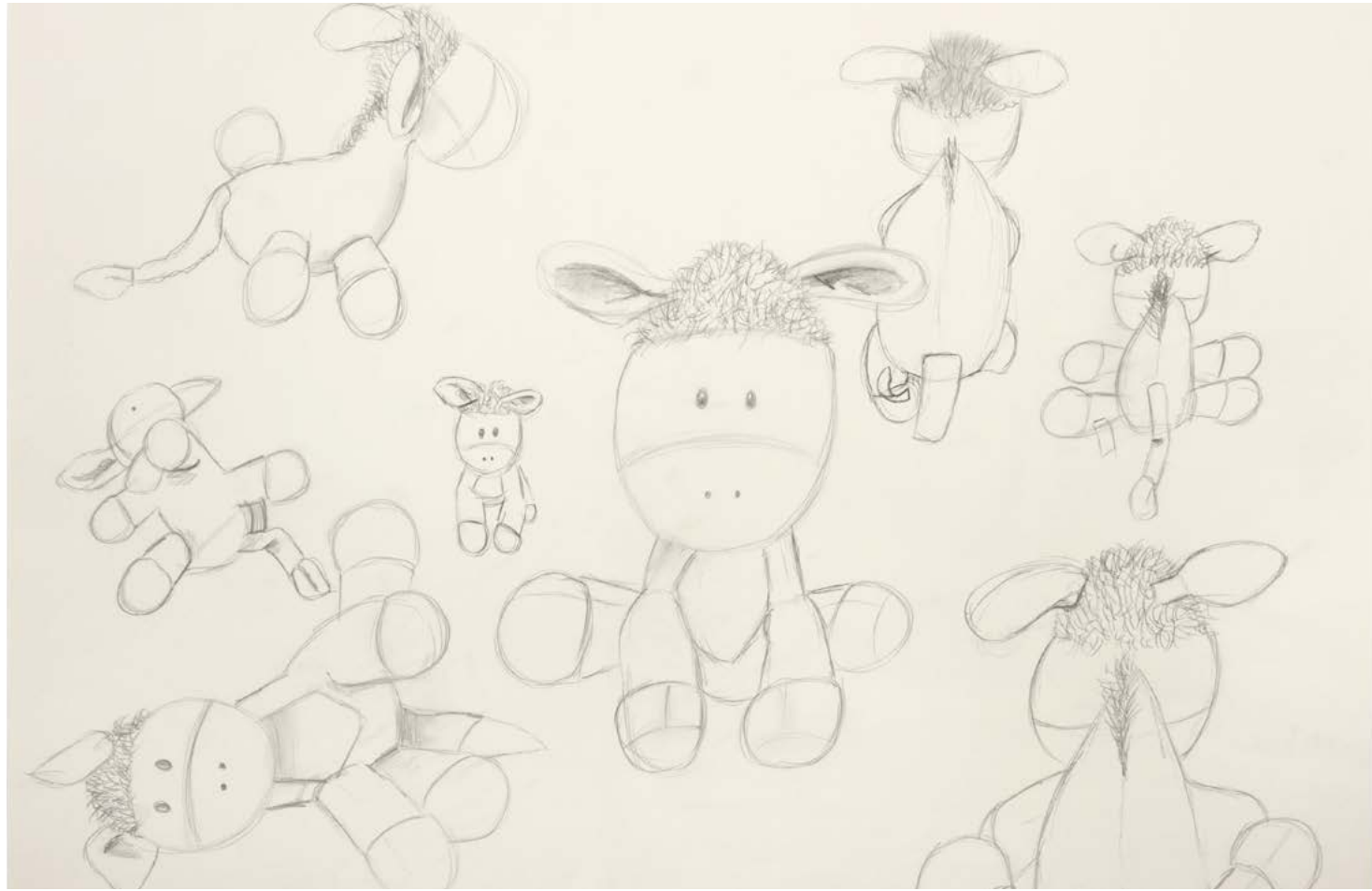



## Shelf by Shelf

Layout, Editorial, Drawing

August 2021

Our study trip in the third year of studies took us to the “Andreas Züst” library in Appenzell. There, all 23 students generated image and text material over four days. My task then was to put this material, together with conversations about reading and books in general, in a publication. My layout deals strongly with the space of the library. Density and airiness, as perceived in the library itself, combine in my book. The image and text material is arranged according to the different bookshelves.

16. Пространственные  
карты



17. Географические карты  
и планы



18



19



20. Фотографии  
планет  
и спутников



20

21

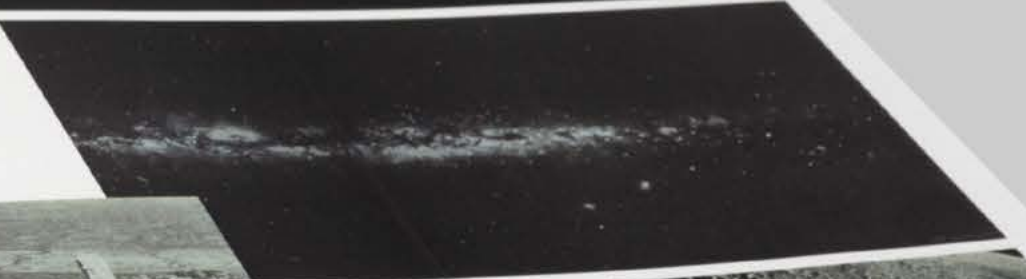

22



23

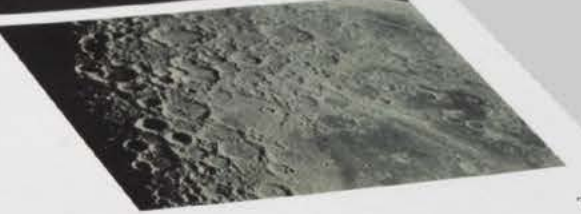

23

2

NI

25 MKU-23/C clip - in subassembly used to mount heavy large-diameter nuclear weapons in bombers. Support bolts were held together by cables which were cut by an explosive-driven wire cutter, thus releasing the bomb. (USAF)



30 8. Das Rohr, das Tyndall bei seinen Versuchen über die Streuung des Lichtes durch feine, in der Luft schwebende Teilchen benutzte. (S. 96)

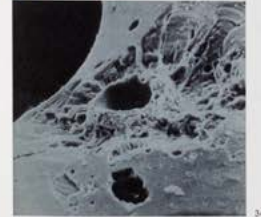

123 285. Portrait de Marcel Duchamp, 1905, aquarelle



206 Scream and water

209 Divina, 1915-204

208 Selbstporträt, 1938. Öl auf Leinwand. Spätschichtweise, wie ein Zeichnergenie. Die röhre, Collagen oder Fotografien, sind ein gegenwärtiges Motiv in Blumenfelds Ceuve.



112 Beverly Hills, September 1979: Barbera und Timothy Leary feiern, nachdem der Bezirksanwalt von Los Angeles eine Anklage gegen sie hat fallenlassen, weil eine nächtliche Razzia keine illegale Drogen hervorbrachte.



112

113 Abb. 25 Puck

115 Avebury Trusloe, Wiltshire, 9. Juni 1991. Besucher klagen über Kopfschmerzen und Benommenheit.

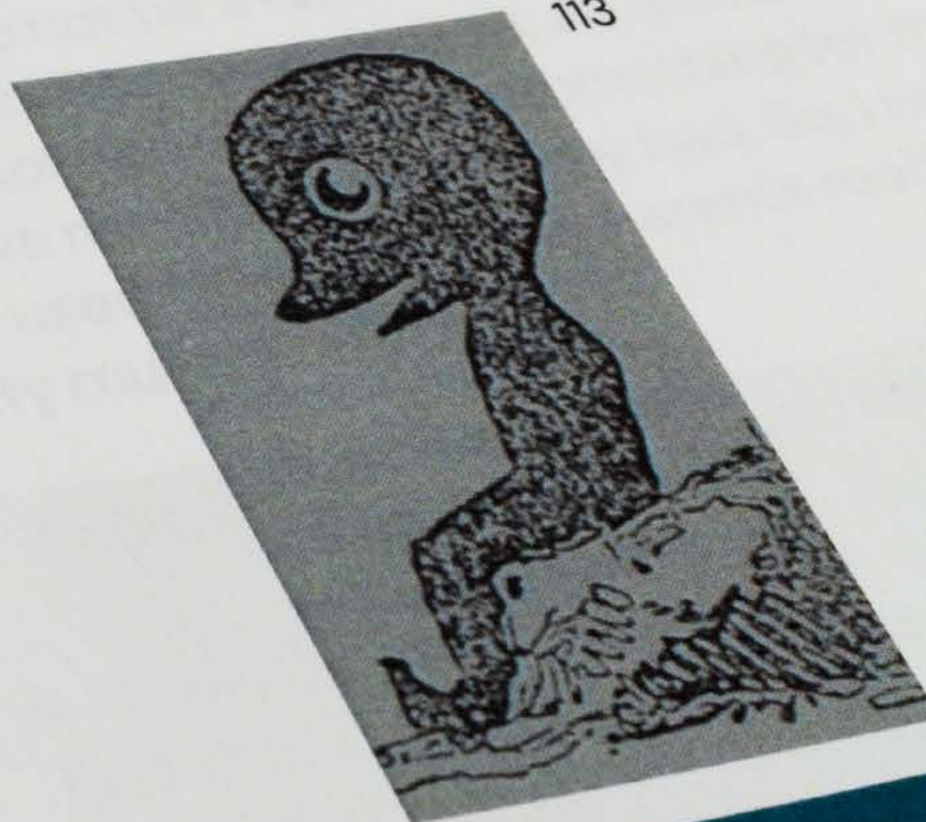

113

114

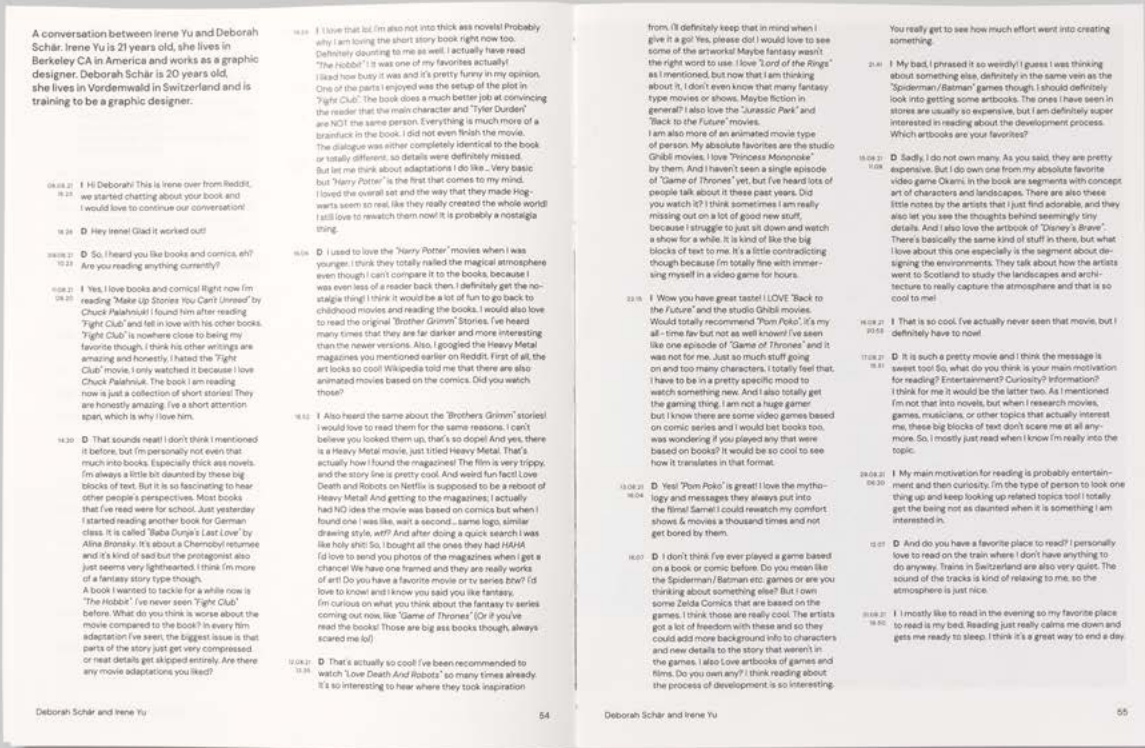

A conversation between Irene Yu and Deborah Schär. Irene Yu is 21 years old, she lives in Berkeley CA in America and works as a graphic designer. Deborah Schär is 20 years old, she lives in Vorderweil in Switzerland and is training to be a graphic designer.

I Hi Deborah! This is Irene over from Reddit, we started chatting about your book and I would love to continue our conversation!

D Hey Irene! Glad it worked out

I So, I heard you like books and comics, are you reading anything currently?

D Yes, I love books and comics! Right now I'm reading 'Make Up Stories: You Can't Unread' by Chuck Palahniuk. I found him after reading 'Fight Club' and fell in love with his other books. 'Fight Club' is nowhere close to being my favorite though, I think his other writings are amazing and honestly, I hated the 'Fight Club' movie. I only watched it because I love Chuck Palahniuk. The book I am reading now is just a collection of short stories. They are honestly amazing. I've a short attention span, which is why I love them.

I That sounds neat! I don't think I mentioned it before, but I'm personally not even that much into books. Especially trick as novels. I'm always a little bit daunted by these big blocks of text. But it is so fascinating to hear other people's perspectives. Most books that I've read were for school. Just yesterday I started reading another book for German class. It is called 'Sabbat's Curse: Last Love' by Alina Bronsky. It's about a Chernobyl survivor and it's kind of sad but the protagonist also just seems very lighthearted. I think I'm more of a fantasy story type though. A book I wanted to tackle for a while now is 'The Hobbit'. I've never seen 'Fight Club' before. What do you think is worse about the movie compared to the book? In every film adaptation I've seen, the biggest issue is that parts of the story just get very compressed or neat details get skipped entirely. Are there any movie adaptations you like?

I I love that lol. I'm also not into thick sci novels! Probably why I am loving the short story book right now too. (obviously daunting to me as well). I actually have read 'The Hobbit'! It was one of my favorites actually! I liked how busy it was and it's pretty funny in my opinion. One of the parts I enjoyed was the setup of the plot in 'Fight Club'. The book does a much better job at convincing the reader that the main character and 'Tyler Durden' are NOT the same person. Everything is much more of a brainfuck in the book. I did not even finish the movie. The dialogue was either completely identical to the book or totally different, so details were definitely missed. But let me think about adaptations I do like... Very basic but 'Harry Potter' is the first that comes to my mind. I loved the overall set and the way that they made Hogwarts seem so real, like they really created the whole world I still love to watch them now! It is probably a nostalgic thing.

D I used to love the 'Harry Potter' movies when I was younger. I think they totally nailed the magical atmosphere even though I can't compare it to the books, because I was even less of a reader back then. I definitely get the nostalgic thing! I think it would be a lot of fun to go back to childhood movies and reading the books. I would also love to read the original 'Brother Grimm' stories. I've heard many times that they are far darker and more interesting than the newer versions. Also, I googled the Heavy Metal magazines you mentioned earlier on Reddit. First of all, the art books so cool! Wikipedia told me that there are also animated movies based on the comics. Did you watch those?

I Also heard the same about the 'Brothers Grimm' stories! I would love to read them for the same reasons. I can't believe you looked them up, that's so dope! And yes, there is a Heavy Metal movie, just titled Heavy Metal. That's actually how I found the magazines! The film is very trippy, and the story line is pretty cool. And weird fun fact! Love Death and Robots on Netflix is supposed to be a reboot of Heavy Metal. And getting to the magazines, I actually had NO idea the movie was based on comics but when I found one I was like, wait a second, same logo, similar drawing style, etc! And after doing a quick search I was like holy shit! So, I bought all the ones they had HAHA. I'd love to send you photos of the magazines when I get a chance! I have one I signed and they are really works of art! Do you have a favorite movie or tv series btw? I'd love to know and I know you said you like fantasy. I'm curious on when you think about the fantasy tv series coming out now, like 'Game of Thrones' (Or if you've read the book! Those are big ass books though, always scared me lol).

D That is actually so cool! I've been recommended to watch 'Love Death and Robots' so many times already. It's so interesting to hear where they took inspiration

from. It definitely keeps that in mind when I give it a go! Yes, please do! I would love to see some of the artwork! Maybe fantasy wasn't the right word to use. I love 'Lord of the Rings' as mentioned, but now that I am thinking about it, I don't even know how many fantasy type movies or shows. Maybe fiction in general? I also love the 'Jurassic Park' and 'Back to the Future' movies.

I I am more of an animated movie type of person. My absolute favorites are the Studio Ghibli movies. I love 'Princess Mononoke' by them. And I haven't seen a single episode of 'Game of Thrones' yet, but I've heard lots of people talk about it these past years. Did you watch it? I think sometimes I am really missing out on a lot of good new stuff, because I struggle to just sit down and watch a show for a while. It is kind of like the big blocks of text to me. It's a little bit of a big block of text to me. It's a little bit of a big block of text to me. It's a little bit of a big block of text to me.

D Sadly, I do not own many. As you said, they are pretty expensive. But I do own one from my absolute favorite video game: Okami. In the book are segments with concept art of characters and landscapes. There are also these little notes by the artists that I just find adorable, and they also let you see the thoughts behind seemingly tiny details. And I also love the artbook of 'Disney's Dream'. There's basically the same kind of stuff in there, but what I love about this one especially is the segment about designing the environments. They talk about how the artists went to Scotland to study the landscapes and architecture to really capture the atmosphere and that is so cool to me!

I That is so cool, I've actually never seen that movie, but I definitely have to not!

D It is such a pretty movie and I think the message is sweet too! So, what do you think is your main motivation for reading? Entertainment? Curiosity? Information? I think for me it would be the latter two. As I mentioned I'm not that into novels, but when I research movies, games, music, or other topics that actually interest me, these big blocks of text don't scare me at all anymore. So, I mostly just read when I know I'm really into the topic.

I My main motivation for reading is probably entertainment and then curiosity. I'm the type of person to look one thing up and keep looking up related topics too! I totally get the being so daunted when it is something I am interested in.

D And do you have a favorite place to read? I personally love to read on the train when I don't have anything to do anymore. Trains in Switzerland are also very quiet. The sound of the tracks is kind of relaxing to me, so the atmosphere is just nice.

I I mostly like to read in the evening so my favorite place to read is my bed. Reading just really carries me down and gets me ready to sleep. I think it's a great way to end a day

D Did you remember the first book you read?

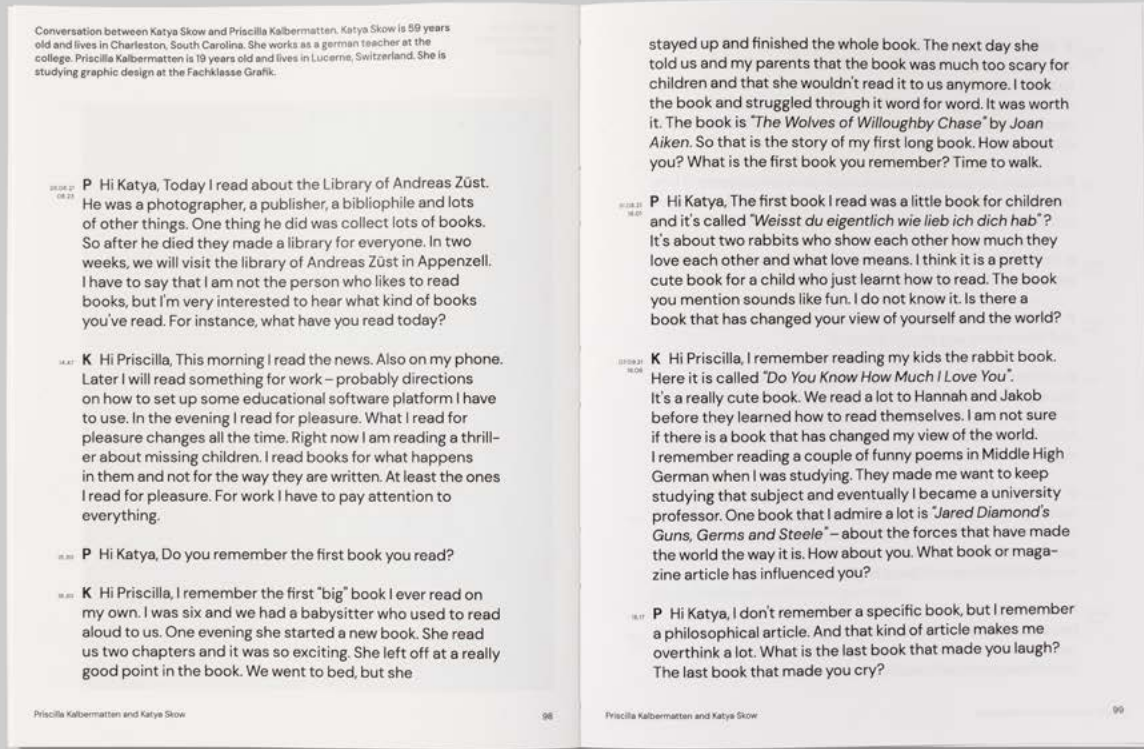

Conversation between Katya Skow and Priscilla Kalbermatten. Katya Skow is 59 years old and lives in Charleston, South Carolina. She works as a German teacher at the college. Priscilla Kalbermatten is 19 years old and lives in Lucerne, Switzerland. She is studying graphic design at the Fachklasse Grafik.

P Hi Katya, Today I read about the Library of Andreas Züst. He was a photographer, a publisher, a bibliophile and lots of other things. One thing he did was collect lots of books. So after he died they made a library for everyone. In two weeks, we will visit the library of Andreas Züst in Appenzell. I have to say that I am not the person who likes to read books, but I'm very interested to hear what kind of books you've read. For instance, what have you read today?

K Hi Priscilla, This morning I read the news. Also on my phone. Later I will read something for work - probably directions on how to set up some educational software platform I have to use. In the evening I read for pleasure. What I read for pleasure changes all the time. Right now I am reading a thriller about missing children. I read books for what happens in them and not for the way they are written. At least the ones I read for pleasure. For work I have to pay attention to everything.

P Did your parents read to you?

K Hi Priscilla, I remember the first "big" book I ever read on my own. I was six and we had a babysitter who used to read aloud to us. One evening she started a new book. She read us two chapters and it was so exciting. She left off at a really good point in the book. We went to bed, but she

stayed up and finished the whole book. The next day she told us and my parents that the book was much too scary for children and that she wouldn't read it to us anymore. I took the book and struggled through it word for word. It was worth it. The book is 'The Wolves of Willoughby Chase' by Joan Aiken. So that is the story of my first long book. How about you? What is the first book you remember? Time to walk.

P Hi Katya, The first book I read was a little book for children and it's called 'Weisst du eigentlich wie lieb ich dich hab'? It's about two rabbits who show each other how much they love each other and what love means. I think it is a pretty cute book for a child who just learnt how to read. The book you mention sounds like fun. I do not know it. Is there a book that has changed your view of yourself and the world?

K Hi Priscilla, I remember reading my kids the rabbit book. Here it is called 'Do You Know How Much I Love You'. It's a really cute book. We read a lot to Hannah and Jakob before they learned how to read themselves. I am not sure if there is a book that has changed my view of the world. I remember reading a couple of funny poems in Middle High German when I was studying. They made me want to keep studying that subject and eventually I became a university professor. One book that I admire a lot is 'Jared Diamond's Guns, Germs and Steele' - about the forces that have made the world the way it is. How about you. What book or magazine article has influenced you?

P Hi Katya, I don't remember a specific book, but I remember a philosophical article. And that kind of article makes me overthink a lot. What is the last book that made you laugh? The last book that made you cry?

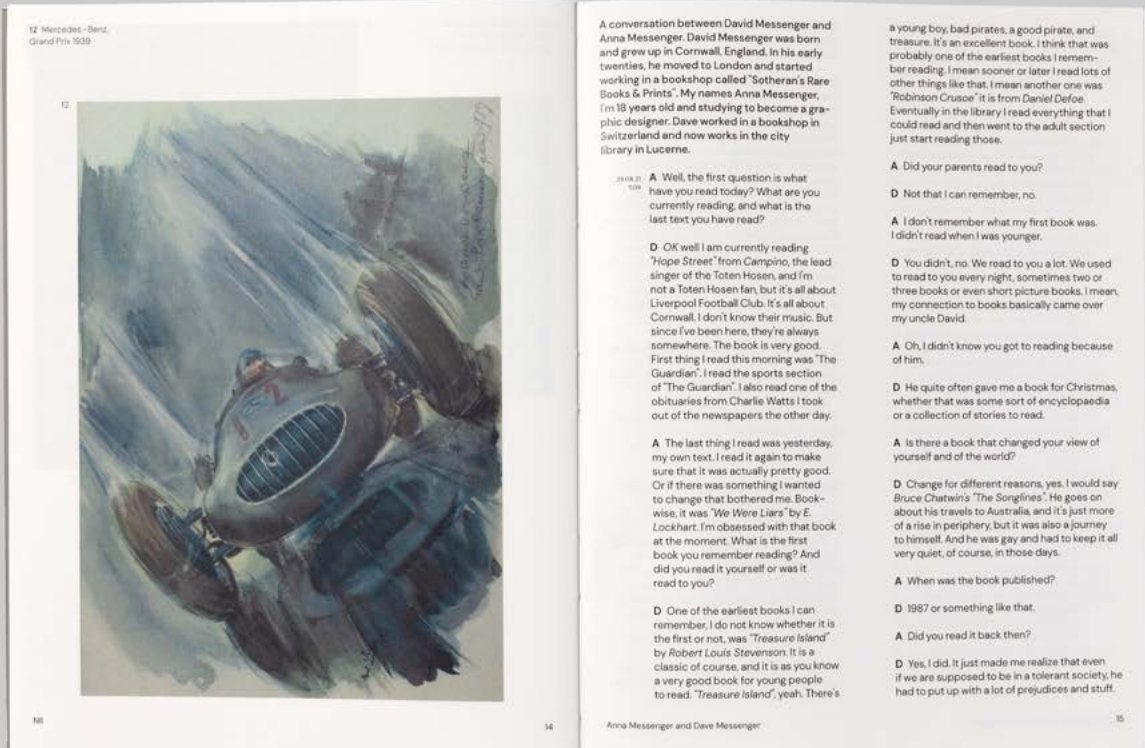

12 Mercedes-Benz Grand Prix 1939



A conversation between David Messenger and Anna Messenger. David Messenger was born and grew up in Cornwall, England. In his early twenties, he moved to London and started working in a bookshop called 'Sotheran's Rare Books & Prints'. My names Anna Messenger. I'm 19 years old and studying to become a graphic designer. Dave worked in a bookshop in Switzerland and now works in the city library in Lucerne.

A Well, the first question is what have you read today? What are you currently reading, and what is the last text you have read?

D OK well I am currently reading 'Hope Street' from Campino, the lead singer of the Toten Hosen and I'm not a Toten Hosen fan, but it's all about Liverpool Football Club. It's all about Cornwall. I don't know their music. But since I've been here, they're always somewhere. The book is very good. First thing I read this morning was 'The Guardian'. I read the sports section of 'The Guardian'. I also read one of the obituaries from Charlie Watts I took out of the newspapers the other day.

A The last thing I read was yesterday, my own text. I read it again to make sure that it was actually pretty good. Or if there was something I wanted to change that bothered me. Book-wise, it was 'We Were Liars' by E. Lockhart. I'm obsessed with that book at the moment. What is the first book you remember reading? And did you read it yourself or was it read to you?

D One of the earliest books I can remember, I do not know whether it is the first or not, was 'Treasure Island' by Robert Louis Stevenson. It is a classic of course, and it is as you know a very good book for young people to read. 'Treasure Island', yeah. There's

a young boy, bad pirates, a good pirate, and treasure. It's an excellent book. I think that was probably one of the earliest books I remember reading. I mean sooner or later I read lots of other things like that. I mean another one was 'Robinson Crusoe' it is from Daniel Defoe. Eventually in the library I read everything that I could read and then went to the adult section just start reading those.

D Did your parents read to you?

D Not that I can remember, no.

A I don't remember what my first book was. I didn't read when I was younger.

D You didn't. We read to you a lot. We used to read to you every night, sometimes two or three books or even short picture books. I mean, my connection to books basically came over my uncle David.

A Oh, I didn't know you got to reading because of him.

D He quite often gave me a book for Christmas, whether that was some sort of encyclopaedia or a collection of stories to read.

A Is there a book that changed your view of yourself and of the world?

D Change for different reasons, yes. I would say Bruce Chatwin's 'The Songlines'. He goes on about his travels to Australia, and it's just more of a rise in periphery, but it was also a journey to himself. And he was gay and had to keep it all very quiet, of course, in those days.

A When was the book published?

D 1987 or something like that.

A Did you read it back then?

D Yes, I did. It just made me realize that even if we are supposed to be in a tolerant society, he had to put up with a lot of prejudices and stuff.

"Potter" movies when I was  
nailed the magical atmosphere  
it to the books, because I  
ck then. I definitely get the no-  
be a lot of fun to go back to  
ng the books. I would also love  
"Grimm" Stories. I've heard  
darker and more interesting  
I googled the Heavy Metal  
earlier on Reddit. First of all, the  
old me that there are also  
e comics. Did you watch

he "Brothers Grimm" stories!  
he same reasons. I can't  
at's so dope! And yes, there  
ed Heavy Metal. That's  
nes! The film is very trippy,  
And weird fun fact! Love  
upposed to be a reboot of  
magazines; I actually  
ed on comics but when I  
nd... same logo, similar  
ing a quick search I was  
ones they had HAHA  
magazines when I get a  
they are really works  
ie or tv series btw? I'd  
you like fantasy,  
ut the fantasy tv series  
nes" (Or if you've

a show for a while. It is kind of like the big  
blocks of text to me. It's a little contradicting  
though because I'm totally fine with immer-  
sing myself in a video game for hours.

22.15 I Wow you have great taste! I LOVE "Back to  
the Future" and the studio Ghibli movies.  
Would totally recommend "Pom Poko", it's my  
all-time fav but not as well known! I've seen  
like one episode of "Game of Thrones" and it  
was not for me. Just so much stuff going  
on and too many characters. I totally feel that.  
I have to be in a pretty specific mood to  
watch something new. And I also totally get  
the gaming thing. I am not a huge gamer  
but I know there are some video games based  
on comic series and I would bet books too,  
was wondering if you played any that were  
based on books? It would be so cool to see  
how it translates in that format.

13.08.21 D Yes! "Pom Poko" is great! I love the mytho-  
16.04 logy and messages they always put into  
the films! Same! I could rewatch my comfort  
shows & movies a thousand times and not  
get bored by them.

16.07 D I don't think I've ever played a game based  
on a book or comic before. Do you mean like  
the Spiderman / Batman etc. games or are you  
thinking about something else? But I own  
some Zelda Comics that are based on the  
games. I think those are really cool. The artists

There's basically the same  
I love about this one espe-  
signing the environment  
went to Scotland to stu-  
ecture to really captu-  
cool to me!

16.08.21 I That is so cool. I've  
20.53 definitely have to n

17.08.21 D It is such a pret  
15.51 sweet tool So, wh  
for reading? Ent  
I think for me it  
I'm not that int  
games, music  
me, these bi  
more. So, I n  
topic.

29.08.21 I My mai  
06.20 ment an  
thing up  
get the  
intere

12.07 D A  
lov  
do  
s  
a

31.08.21  
18.50



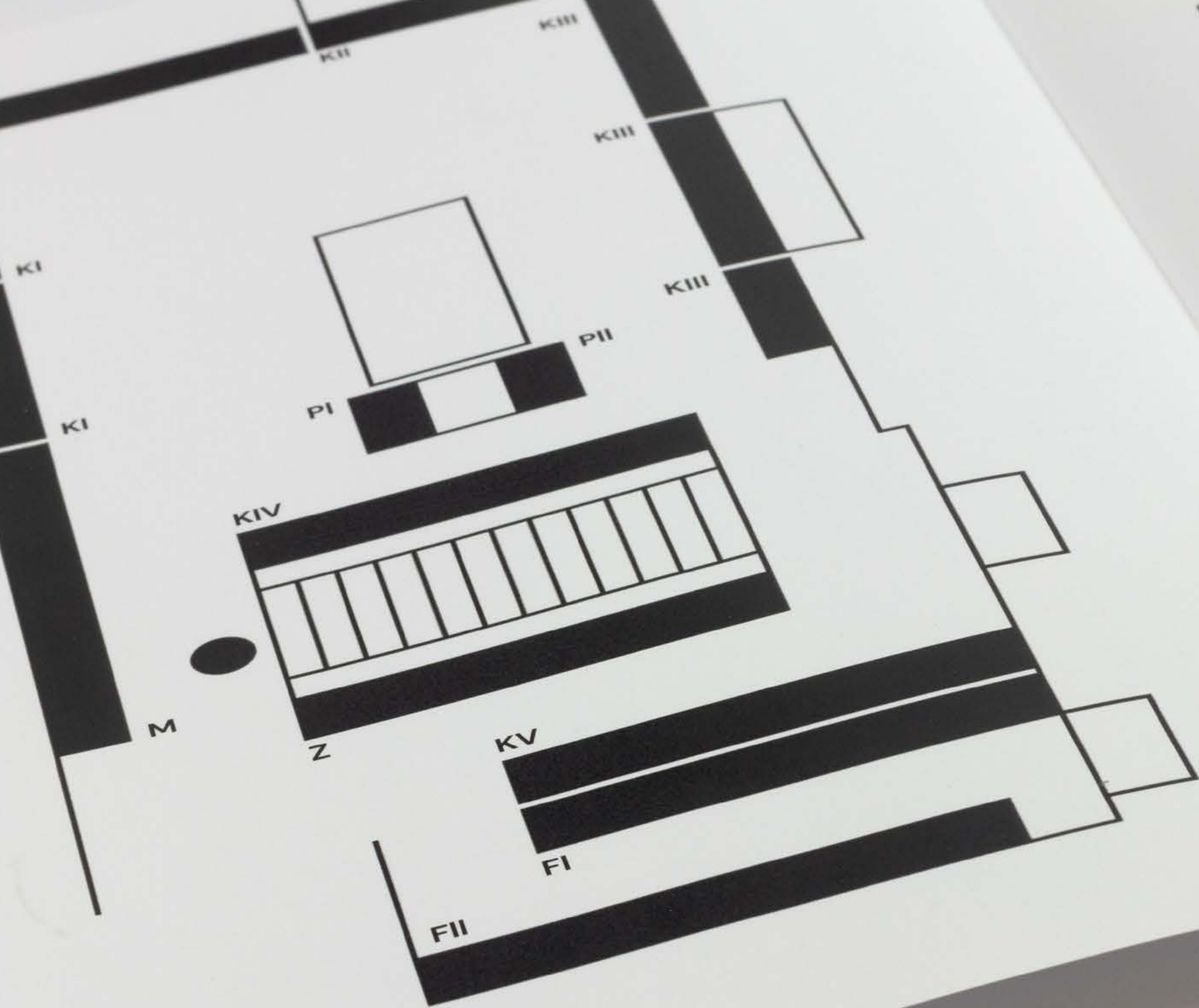

PI	Kunst II	Charlotte
KI	Kunst III	Valerie Bühler
KII	Philosophie II	Arno Röthlin
KIII	Kunst KIV	Noah Suparna
PII	Zeitschriften	Julia Hegi
KIV	Kunst V	Chiara Huber
Z	Fotografie I	Sophie Vogel
KV	Fotografie II	Akira Yamaguchi Elia Boccia
FI		
FII		

table of contents

Index second floor  
Imprint

From A as in Andreas to Z as in Züst

Andreas Züst was a geologist, weather observer, photographer, painter, poet, editor, publisher and collector. He died in 2000 at the age of 82 leaving behind a remarkable, but partially unknown collection of 2200 books in his home. His daughter took on the difficult task of cataloguing Züst's "collection of invaluable and rare". As the library largely consists of books that are very difficult to access these volumes, she was faced with the challenge: how to bring some sort of order into a library that documents a lifelong passion for collecting books, not according to any conventional method but by following a deeply personal and unpredictable range of interests? The library found a new home in the Parcours - Haus Regional at 100 metres above sea level, with Züst's name on the white walls and the title written on the door to the library is a warning: "Whoever ventures into this space for research is threatened with linguistic imprisonment".

In 2011, the Andreas Züst Library was the focus of the editorial project of the Fachklasse Grafik Luzern, using the working title "From A as in Andreas to Z as in Züst". 23 students searched their own "specialisms" into the library in order to collect ten images each which were connected to some way according to criteria defined by the individual student. The resulting 230 illustrations, together with their captions and hand-drawn cover images, were then brought together to form a kind of hybrid - book version of the library in this way, images that have spent many years in close proximity to each other, but in different buildings, where this is now danger to other books seen not just of the library but also of the collector himself, Andreas Züst.

As this interdisciplinary project combined the subjects of English and design, the "bookish" assemblage of images is combined with 23 conversations the students, using a variety of media, conducted with English speaking friends and acquaintances all over the world, about reading as an activity, and their lives with books.

The book you are holding in your hands is the work of Chiara Huber.

We hope you have as much fun reading it as we had making it!

Marina Wüdi  
Hildegard Koller

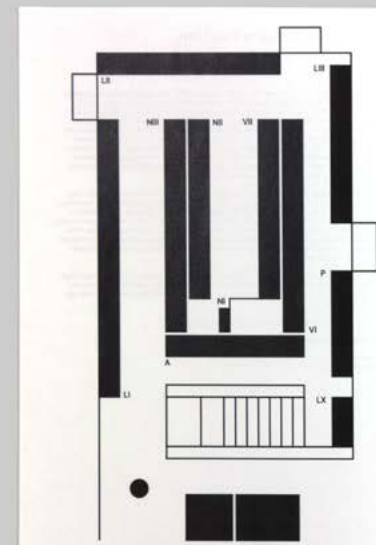

first floor

The library Andreas Züst	1
Questions to Andreas Züst	2
Starg words	5
LI Literatur I Eva Aftenger	6
NI Naturwissenschaften I Anna Messinger	9
VI Völker, Länder, Reisen I Yasmin Sabuni Leonard Sanchez	22
VI Völker, Länder, Reisen II Sahar	28
LI Literatur II Sara Muesmann	32
VI Völker, Länder, Reisen I Yasmin Sabuni	36
P Politik Paula Neumann	43
LX Lexik Heidi Wüdi Oliver Schae	46
A Architektur, Film, Musik, Comic Tajana Steiner	50
Index first floor	56
Impressum	67

Wald of Luzern



Index second floor



## Literatur I



1 Okay Mutter, ich nehme die Mittagsmaschine  
Beste Kolumnen  
Max Goldt  
Haffmans, 1999  
LABA G010  
3-251-00440-9

## Naturwissenschaften II



2 Kunstformen der Natur  
Erich Haeckel  
Prestel, 1998  
NG 013  
96298



3 International Cloud Atlas  
Volume II  
World Meteorological  
Organization  
Geneva World Meteorological  
Organization, 1987  
NDA 046  
1288505



4 Feuerberge  
Hahn Otto  
Herder, 1987  
NFC 002  
3-451-21001-0



5 Eiszeitalter 2  
Die jüngste Erdgeschichte  
der Schweiz und ihrer  
Nachbargebiete  
Hantke René  
Ott, 1980  
NFF 015  
3-7225-6259-7



6 Vulkanausbruch  
Ursachen und Risiken  
Münchner Rückversicherung, 1983  
NFC 012



7 Fullerene: Die Buckyballs  
erobern die Chemie  
Joachim Dettmann  
Birkhäuser, 1994  
NC 001  
1287938



8 Feuerberge  
Otto Hahn  
Herder, 1987  
NFC 002  
3-451-21001-0



9 Kein Platz für wilde Tiere  
Bernhard Grzimek  
Schweizer Druck- und  
Verlagshaus, 1954  
NHC 014



10 Lexikon der Mykologie  
Dörfelt Heinrich  
Fischer, 1989  
NHB 003  
3437204130



11 Vom Wetteraberglauben  
zur Wetterforschung  
Hans-Günther Körber  
Edition Leipzig, 1987  
NDA 001



12 Liska Hans  
Daimler-Benz Aktiengesellschaft,  
Stuttgard - Untertürkheim  
Cantz, 1951  
NJI 014  
1301744



13 THE SHELL  
Five Hundred Million Years  
of Inspired Design  
Hugh und Marguerite Stix and  
R. Tucker Abbott  
Abrahms, 2000  
NFD 018  
1292222



14 Wiesenblumenfiabel  
Amstutz, Walter (Hrsg.)  
Bruckmann, 1943  
NHA 007



15 Mit Raketenkraft ins Weltall  
vom Feuerwagen zum Raumschiff  
Gail Otto Willi  
Thienemanns, 1928  
NJFF 021

## Naturwissenschaften I



16 Vulkanismus  
Naturgewalt, Klimafaktor und  
kosmische Formkraft  
Hans Pichler  
Spektrum der Wissenschaft, 1985  
NFC 016  
3-922508-32-4



17 Fotoatlas der Planeten  
Das neue Bild des Sonnensystems  
Geoffrey Briggs, Fredric Taylor  
Kosmos Verlag, 1982  
NAHD A003  
3-440-05306-7



18 Catalogue of the Universe  
Paul Murdin and David Allen  
Cambridge University Press, 1979  
NAHE 046  
0-521-22859-X



19 Le Ciel  
Notins élémentaires  
Amédée Guillmein  
Librairie Hachette, 1877  
NAHA 009



20 Huber Chiara 10  
Die Sonne  
Das Gestirn in der Kultur-  
geschichte  
Masanjeet Singh  
Wasmuth, 1993  
NAHD C012  
38030-3059-5



21 Die neue Astronomie  
Nigel Henbest, Michael Marten  
Birkhäuser Verlag, 1984  
NAHC 051

3-7643-1616-0



22 Der neu entdeckte Himmel  
Das astronomische Weltbild  
gemäss jüngster Forschung  
Robert Henseling  
Atlantis Verlag, 1930  
NAHD A006



23 In die Tiefen des Weltalls  
Jefremow, Ju. N.  
Thun, 1990  
NAHC 009  
3-8171-1153-3



24 Erdsicht  
Global Change  
Diverse Autoren  
Gerd Hatje, 1992  
NAHD D013

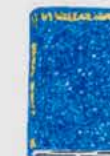

25 US Nuclear Weapons  
the Secret History  
Chuck Hansen  
Aerofax, 1988  
NAG 024  
0-517-56740-7



## Colour study

Colour

May 2020

As a graphic designer, I am confronted with colour every day. Colour is ubiquitous these days, but how is it actually created? In this project, I learned how to make my own watercolour and gouache paints from different pigments and binders. I experimented with the different ways of applying and mixing colour. I also investigated the behaviour of the colour when adding liquids, such as vinegar. In this way, surprising and fascinating results emerged.

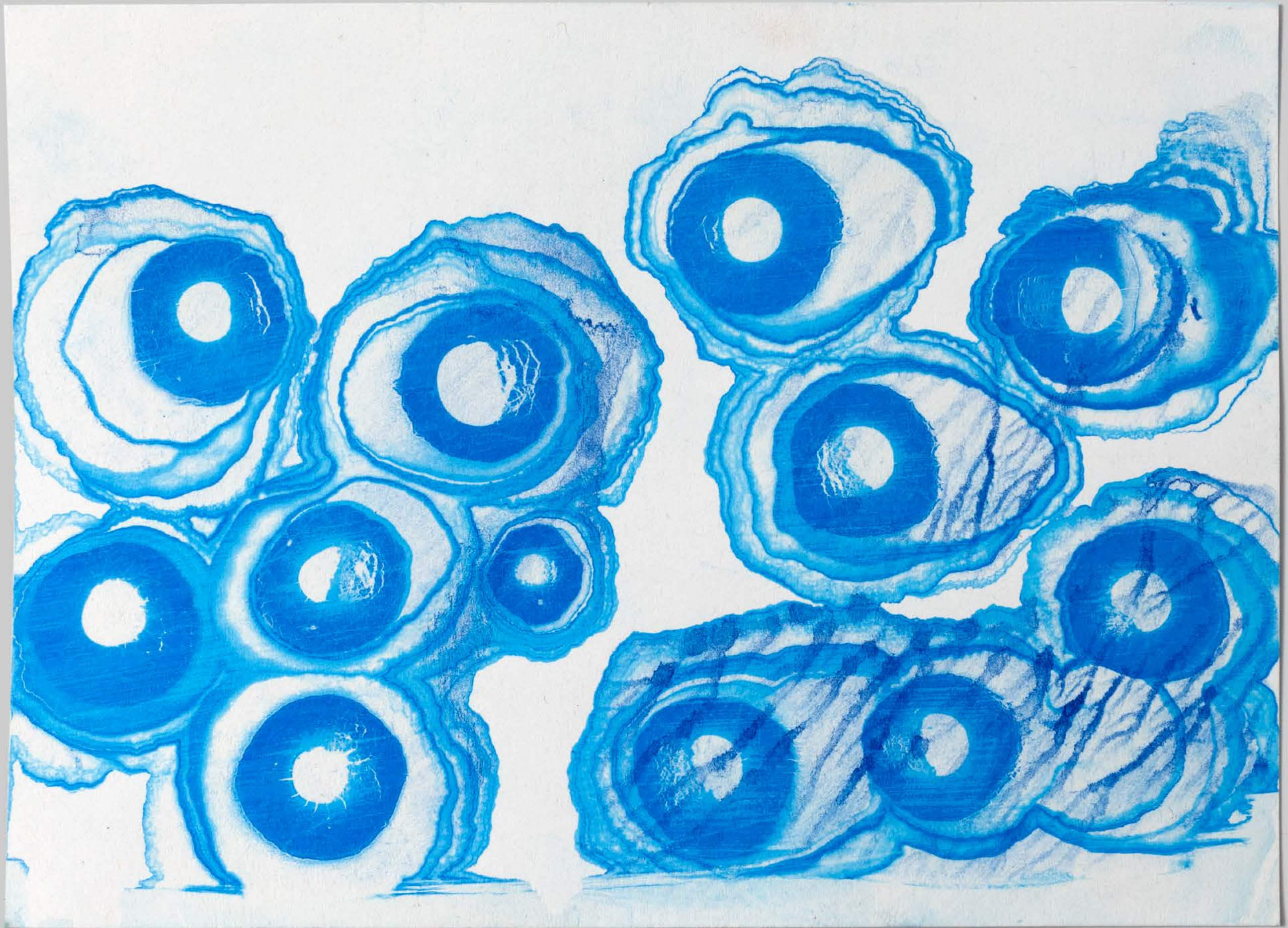



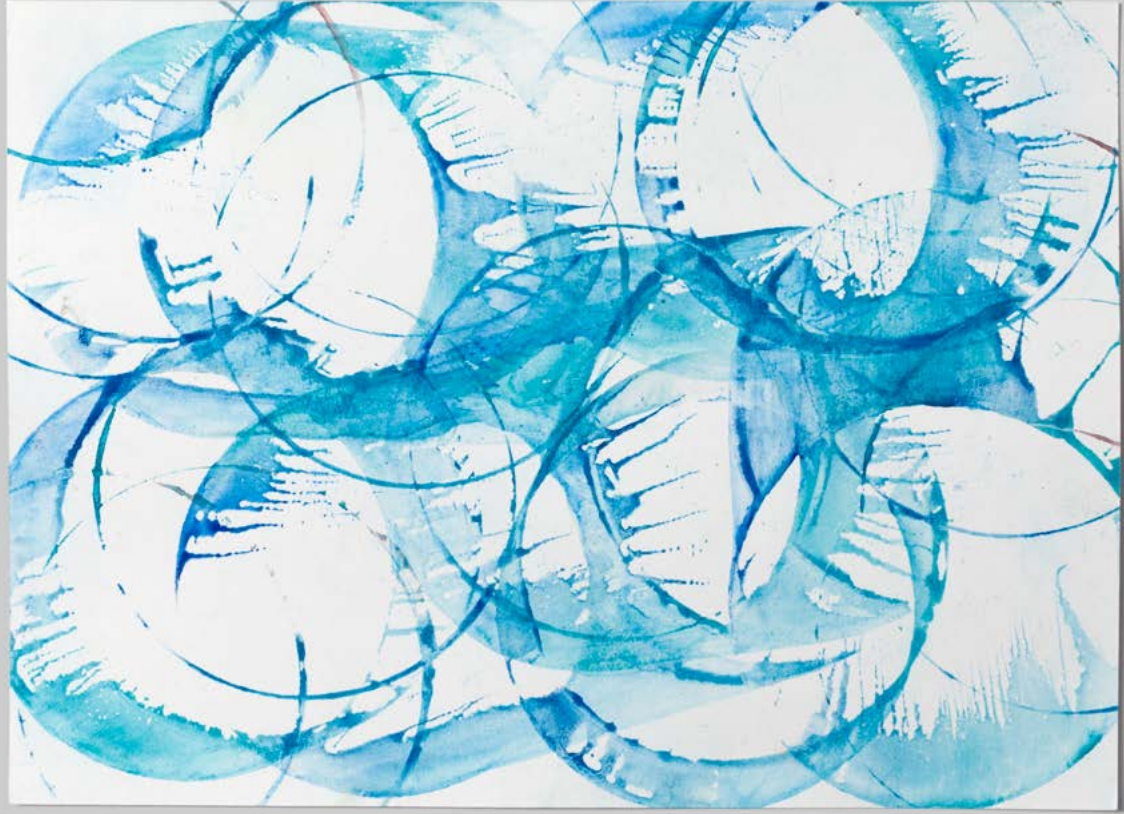

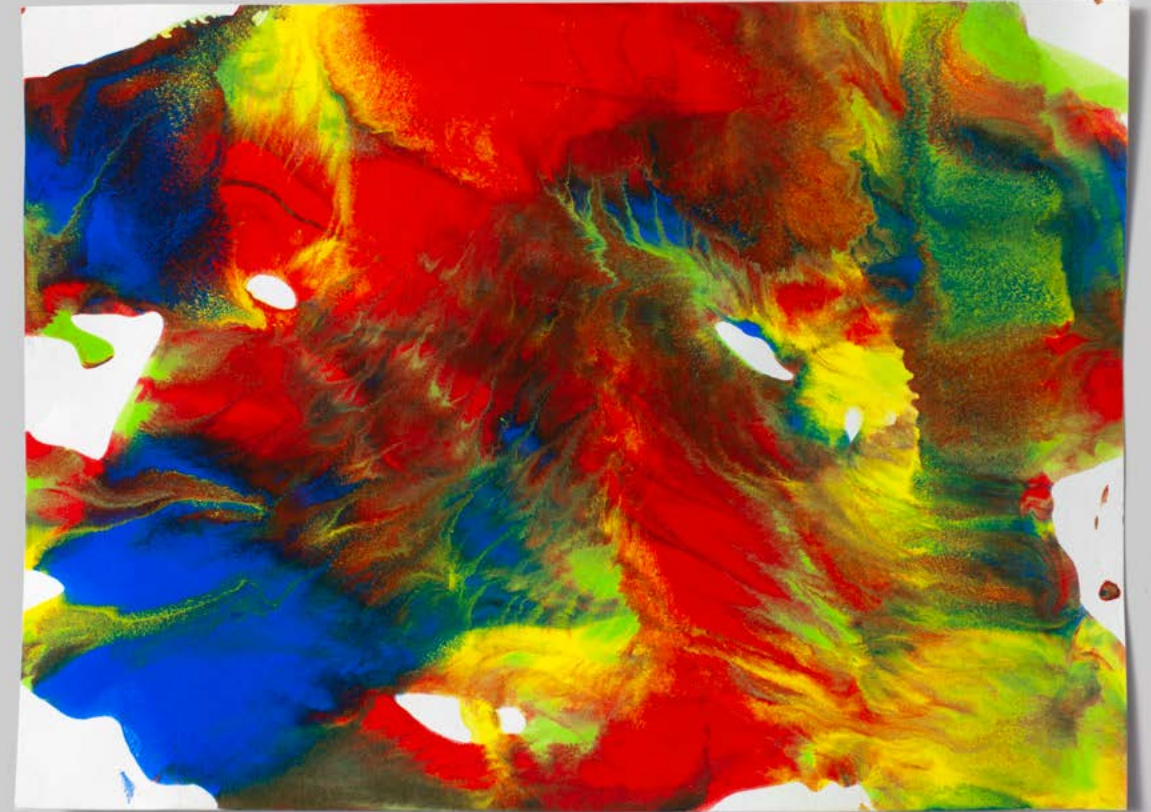

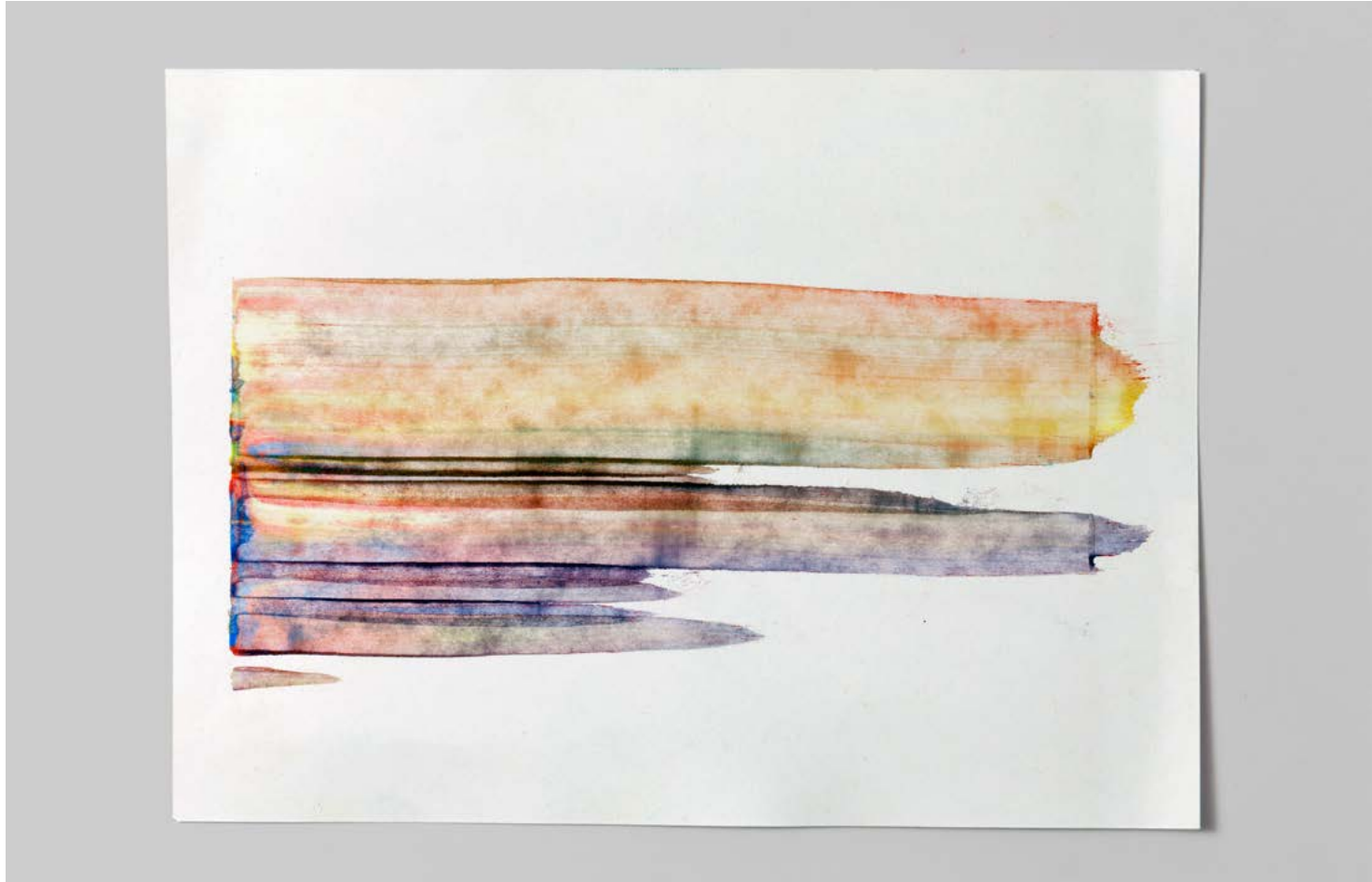



## Master's graduation concerts

Typography, Illustration

March 2021

Lucerne University – Music

I was commissioned by the “Lucerne University of Music” to design a poster for the Master’s graduation concerts. The topic of synaesthesia aroused my interest. What shapes and colours do we perceive when we listen to music? What does music trigger in us? How do we make rhythm and sound visible? I experimented with shapes cut out of paper, which I distorted over the scanner using analogue technology. I combined the resulting coloured, organic lines, and shapes with static typography to create two versions of the poster.

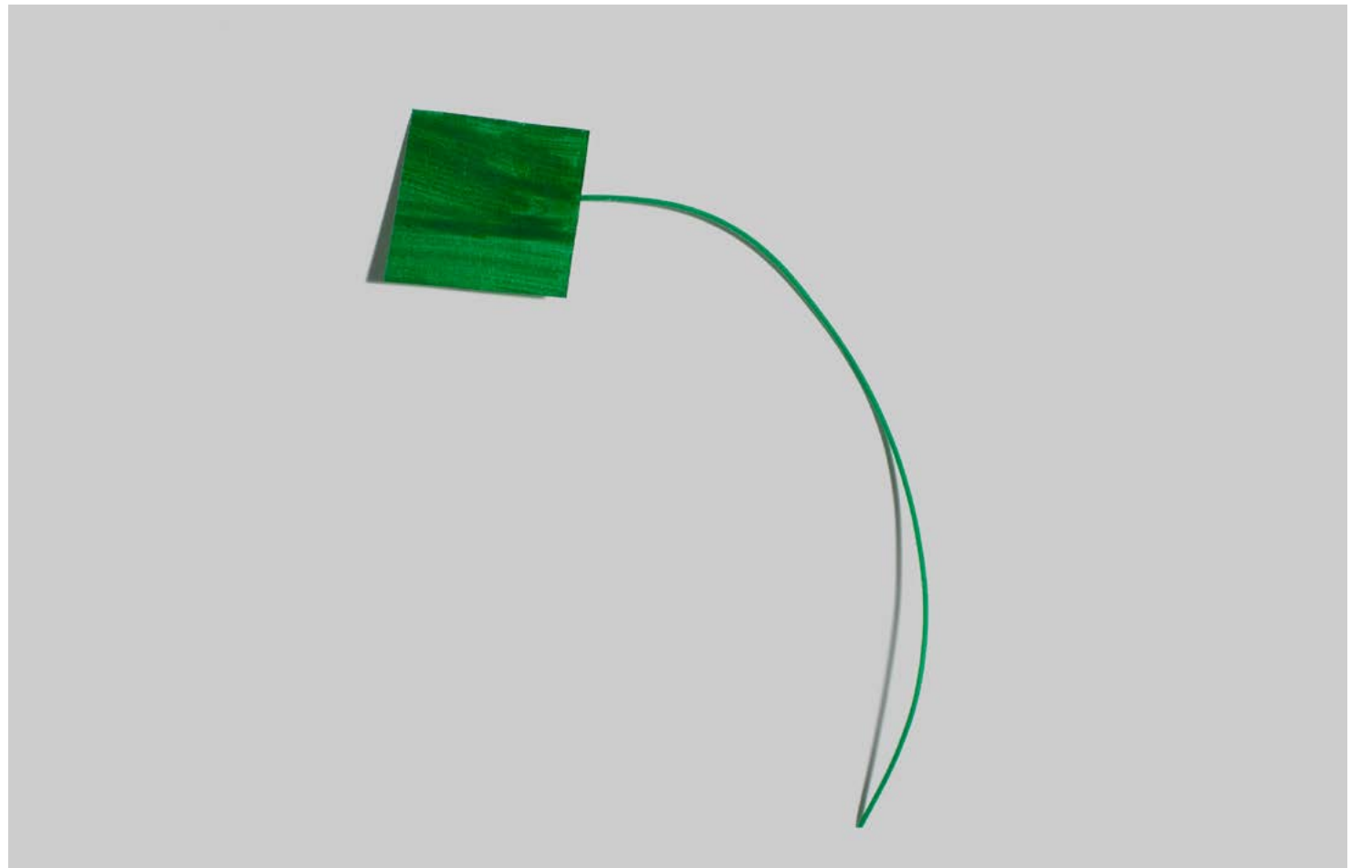
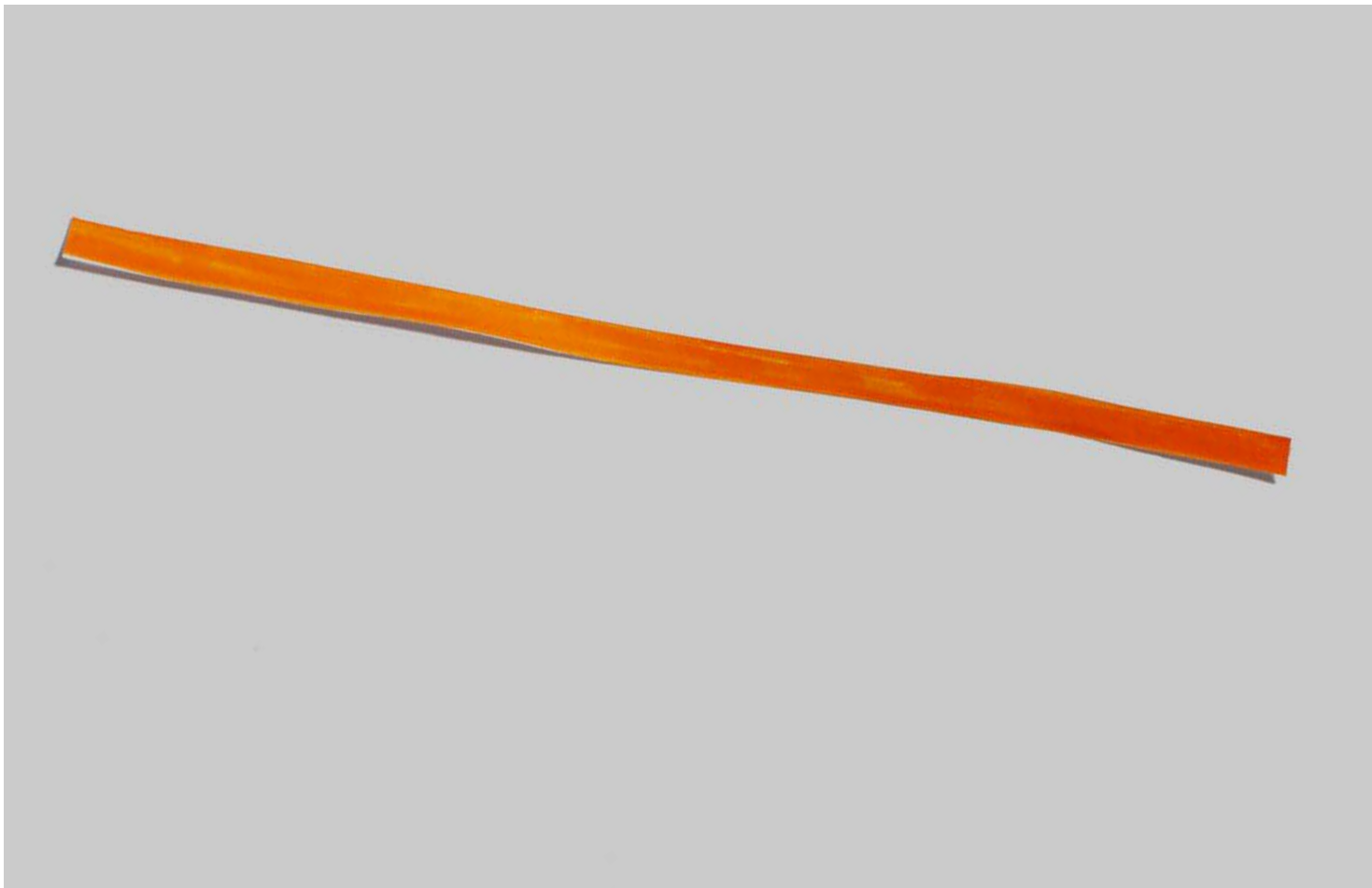
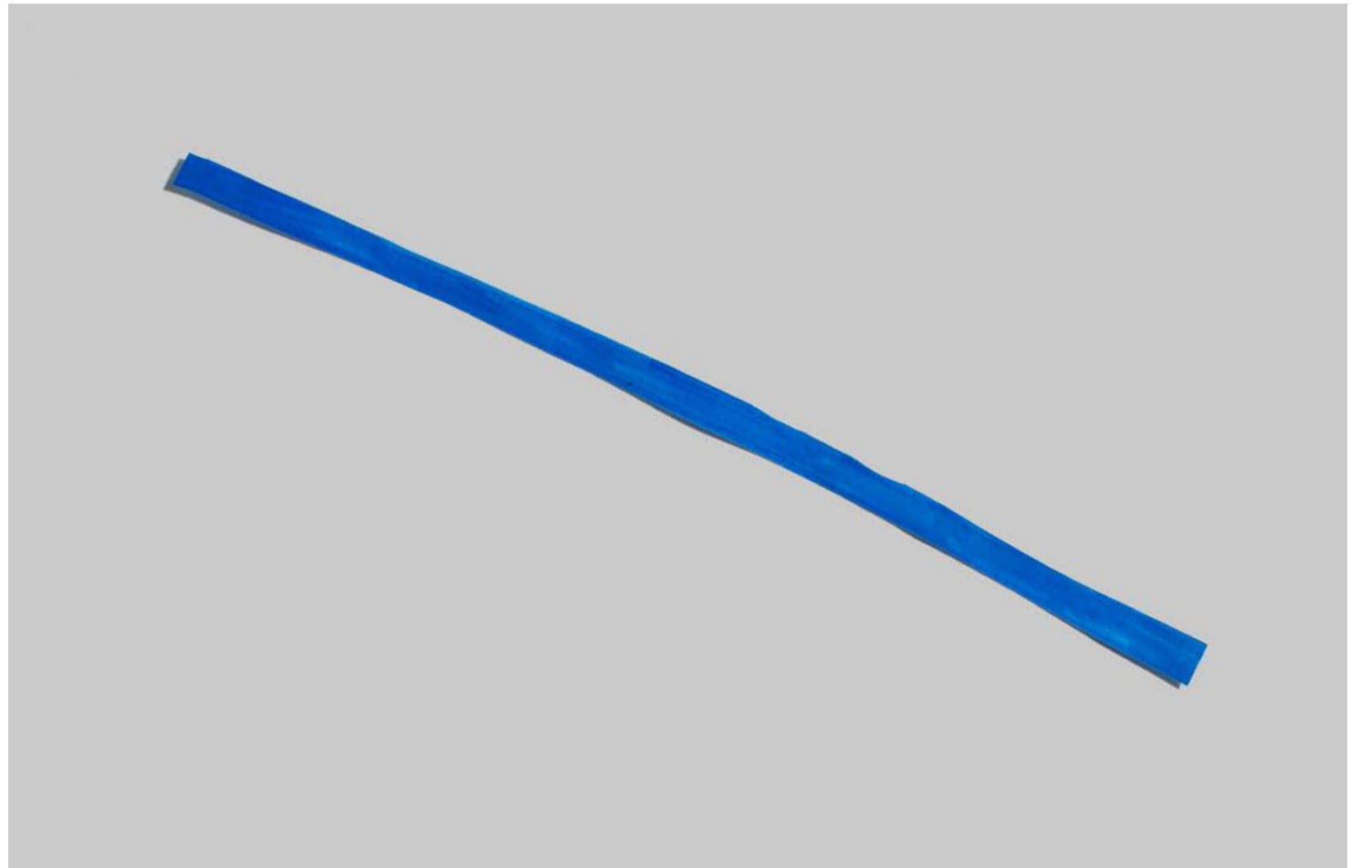





**The traces of everyday life**  
Layout, Photography, Drawing  
August 2020



Our task was to visually capture an assigned district during one week and to work out its character. I focused on the traces of everyday life. To do this, I drew movements of people, vehicles, and animals for one minute at different locations – flight tracks of birds, walking tracks of people or movements of means of transport. I summarised this material in a small-format layout. The legends show where which tracks come from and where they were recorded. I have added descriptive sentence fragments to the traces that I perceived at the place. This leaves room for your own imagination.

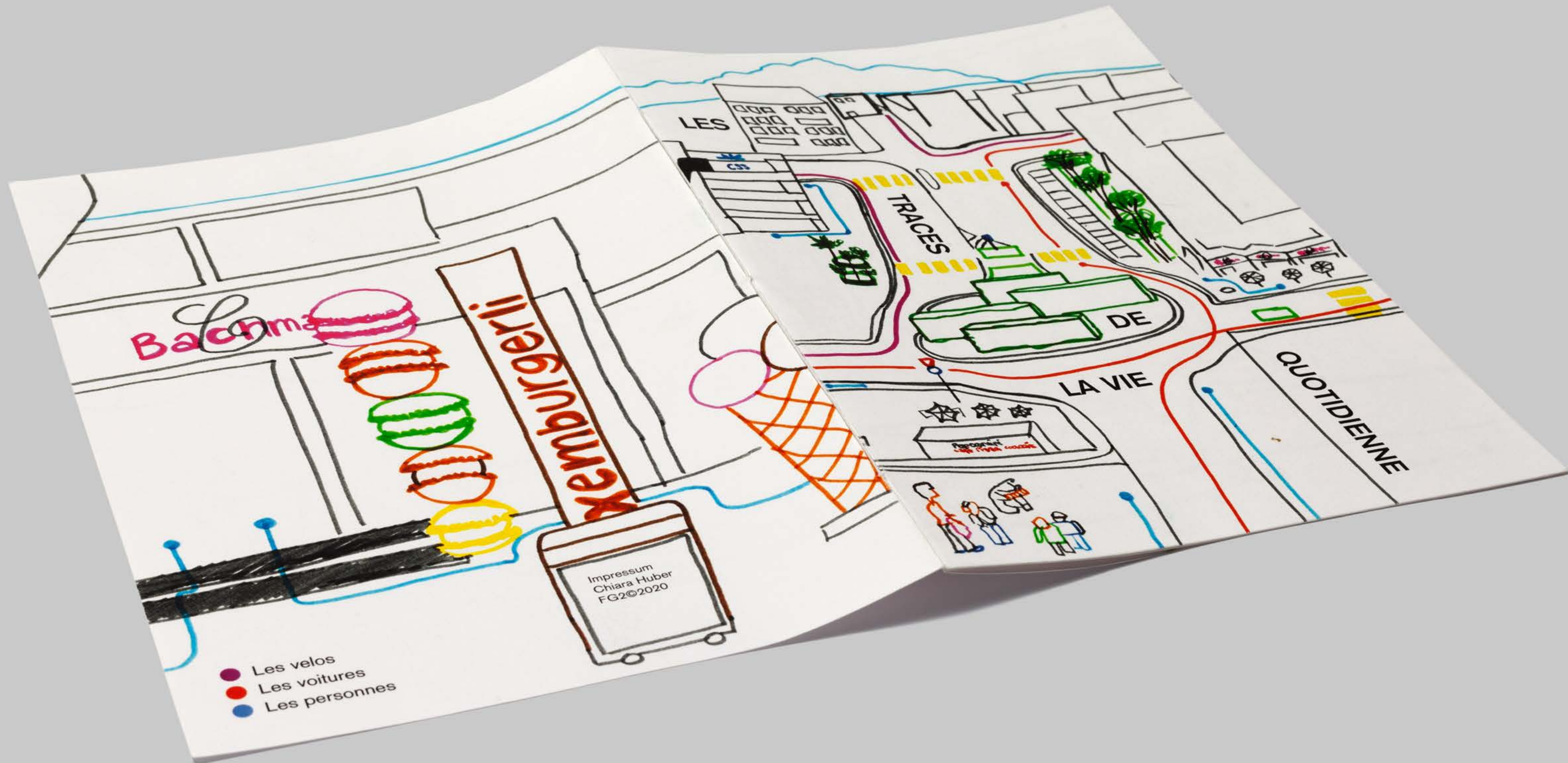

- Les velos
- Les voitures
- Les personnes

Impressum  
Chiara Huber  
FG2©2020

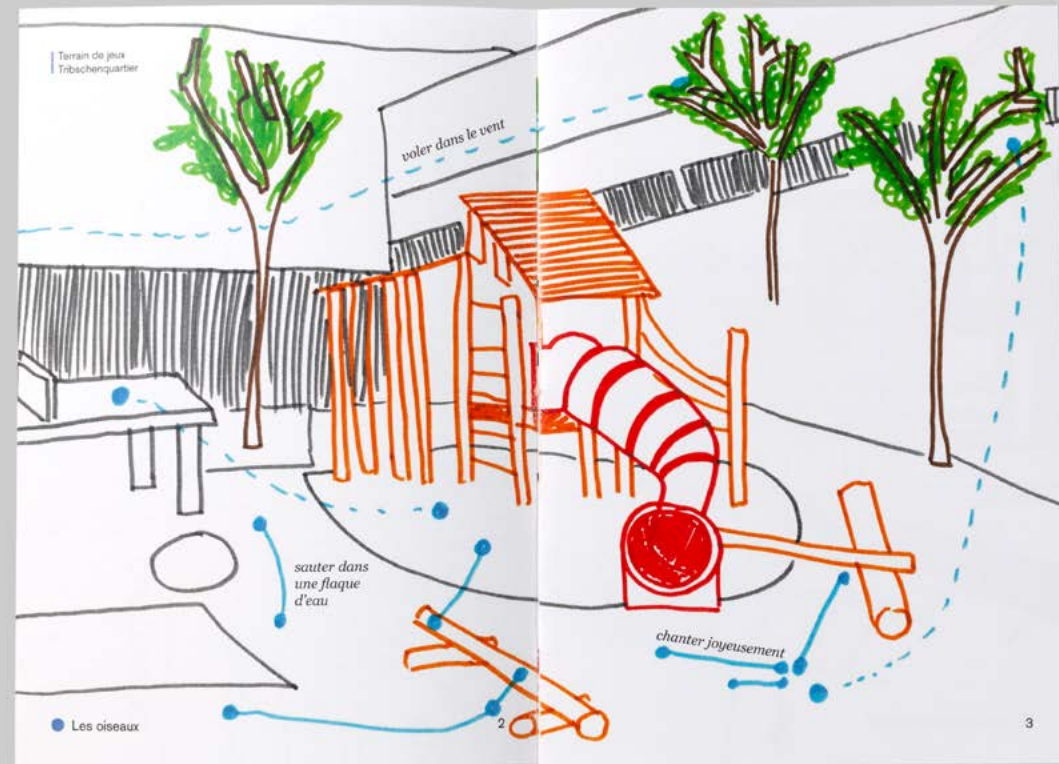
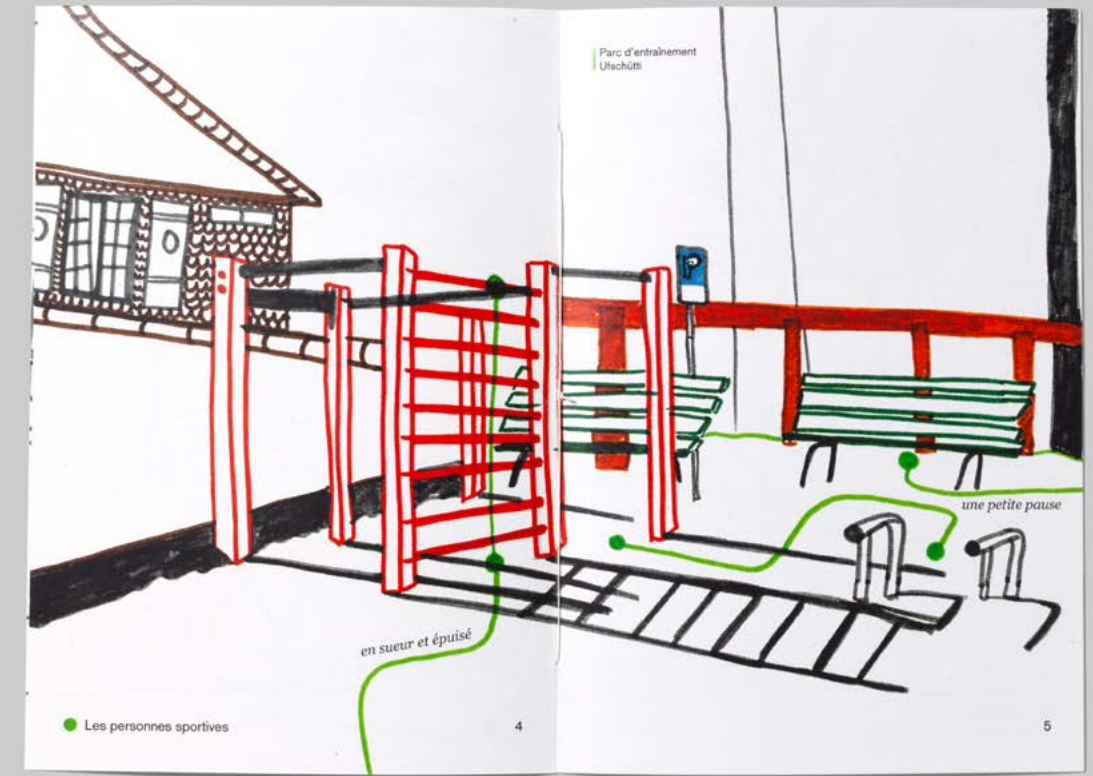
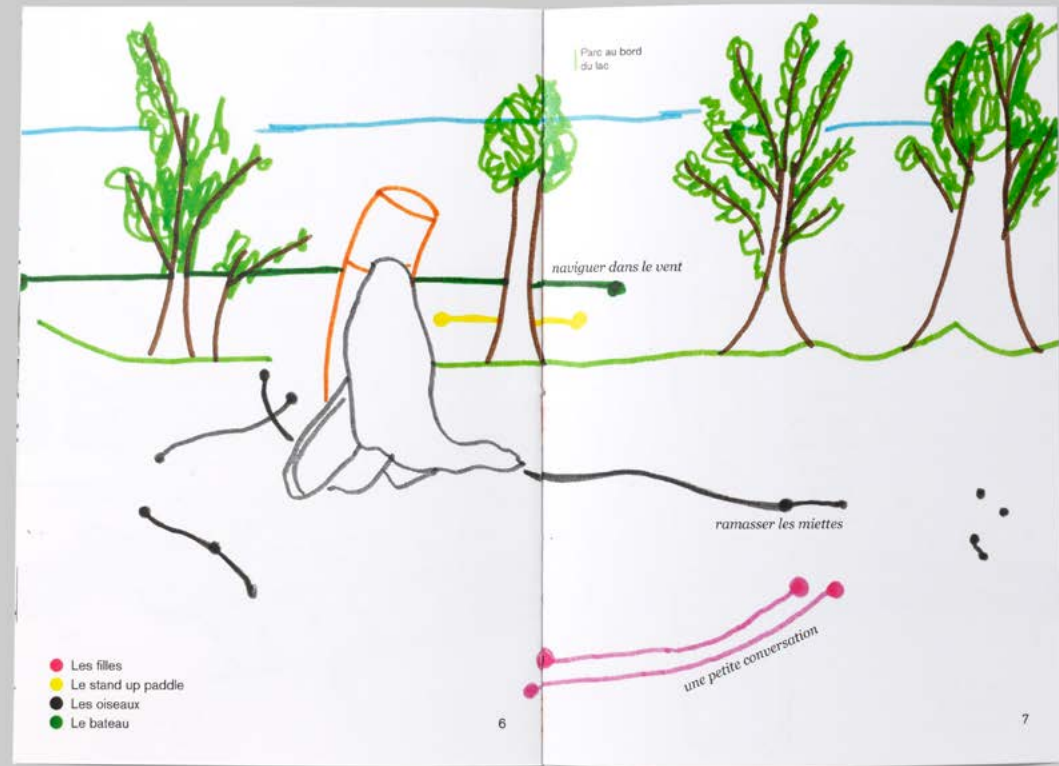

Terrain de jeux  
Tribschenquartier



● Les personnes sportives

en sueur et épuisé



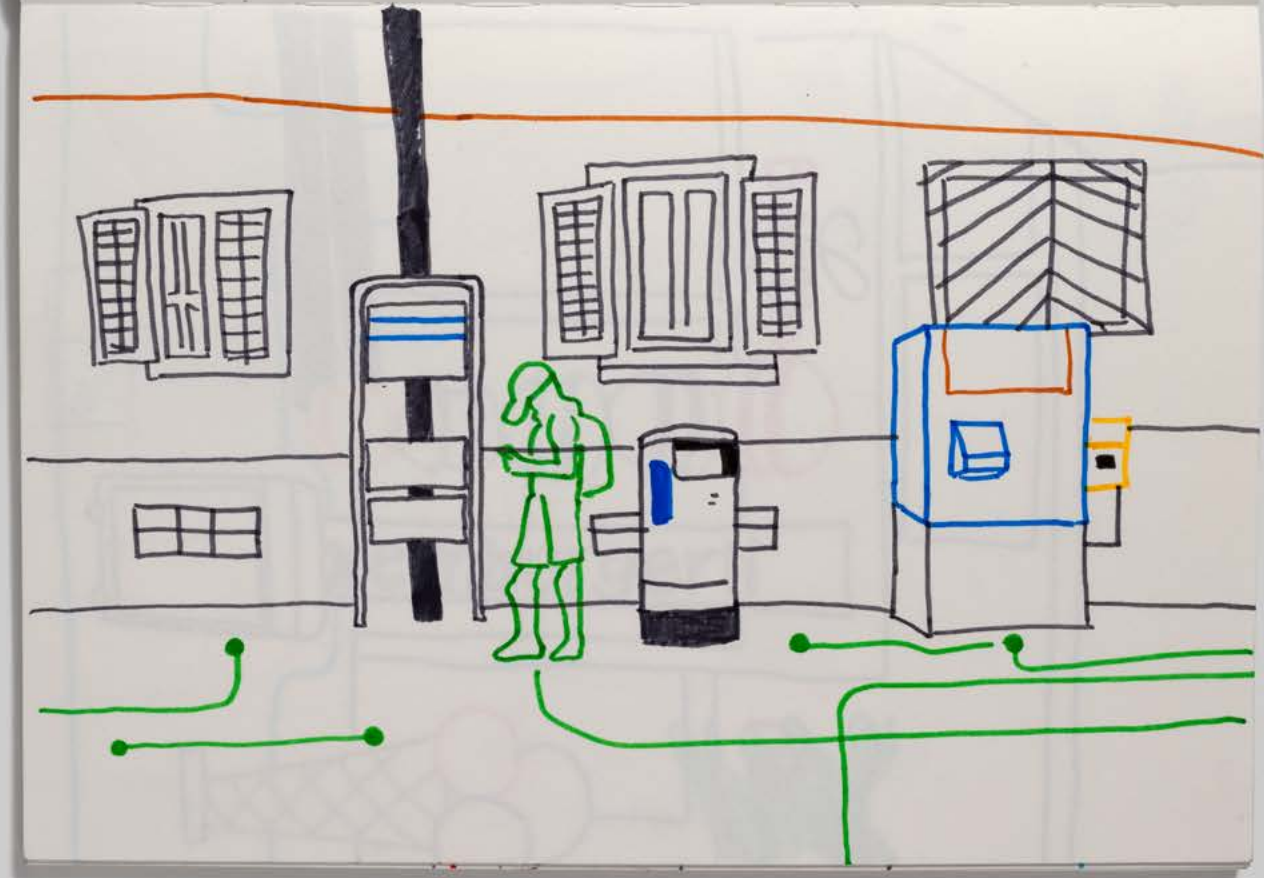
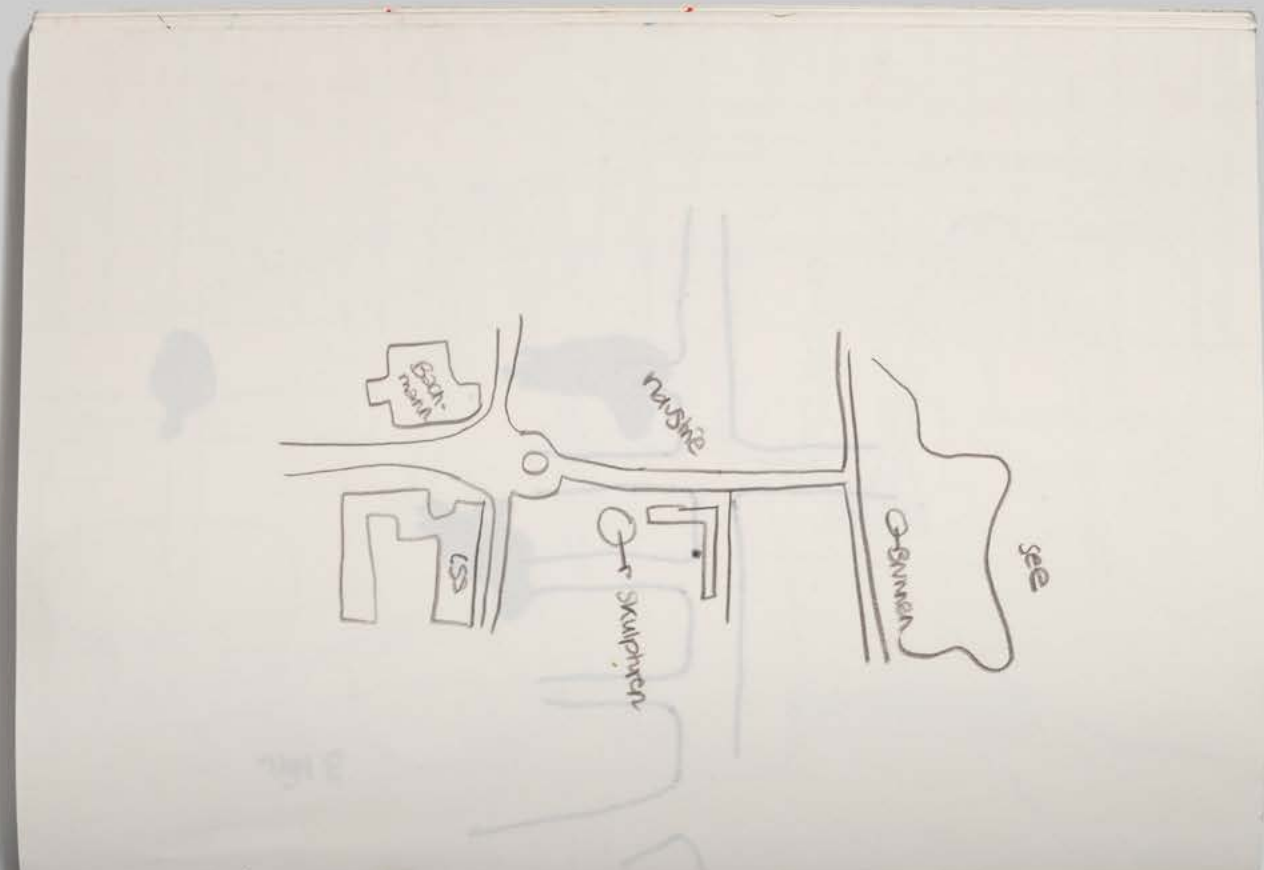
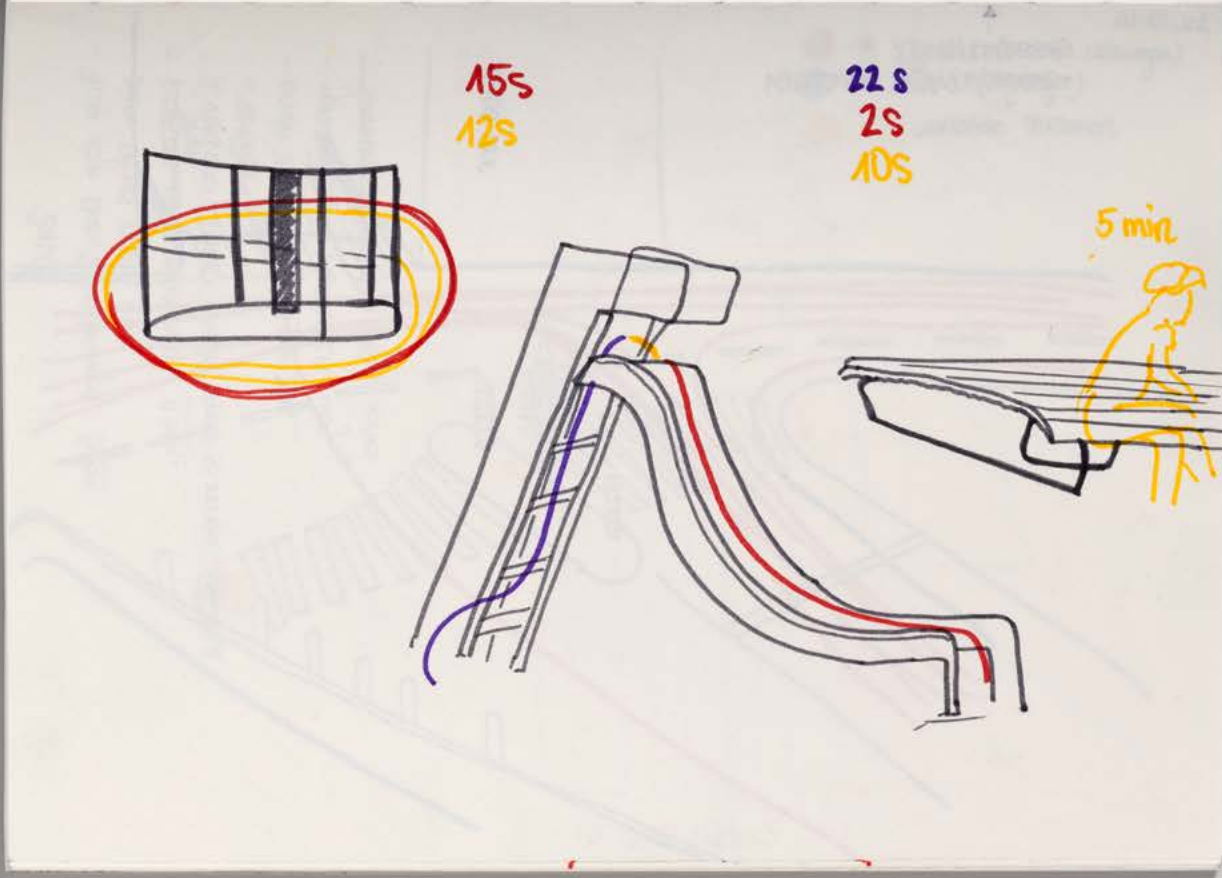
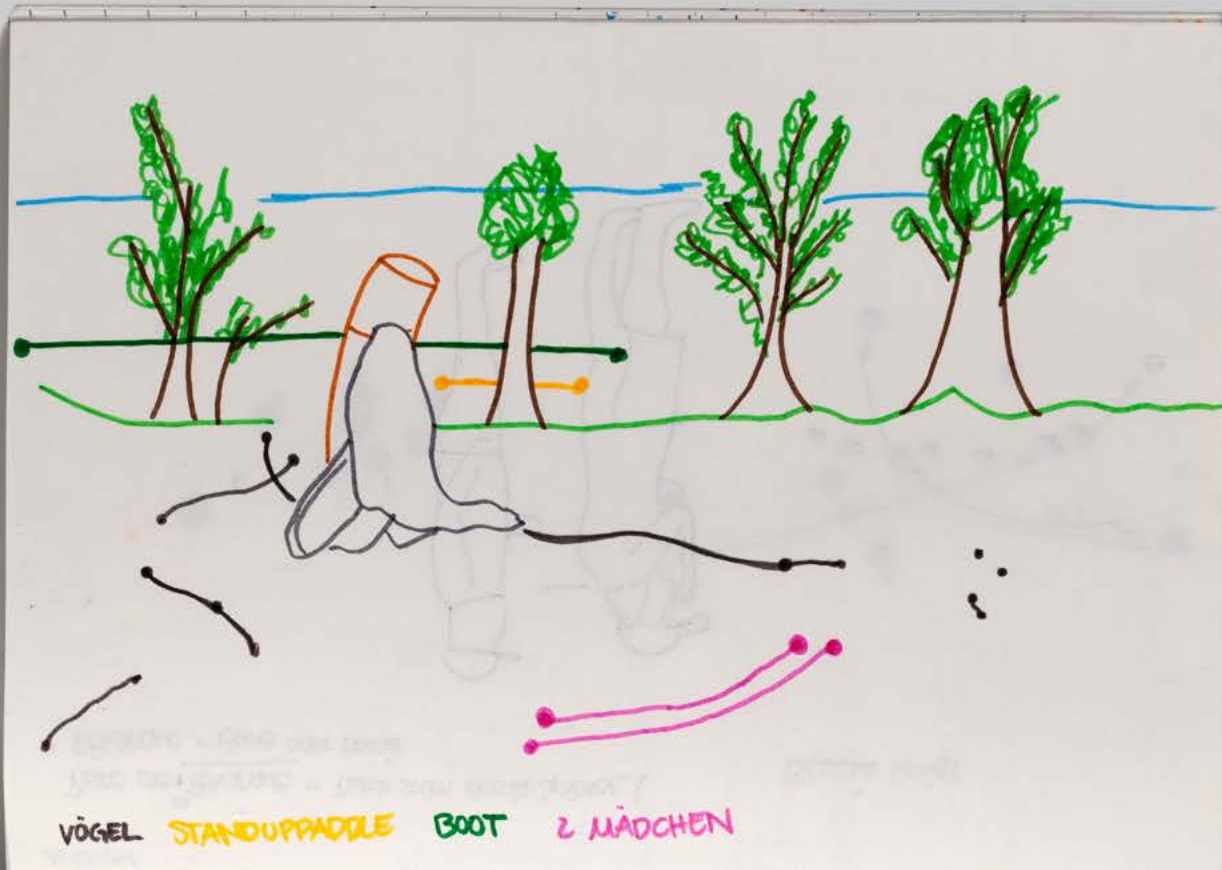



## Calligraphy

Typography, Calligraphy

September 2019

At the beginning of the 1st year of studies, I first discovered my fascination for type design in the calligraphy course. In a first part, we learned the art of calligraphy with brush and ink. In a second part, we designed a word mark under the term “Hapek”. It contains important letter parts that could be used to derive an entire font. I designed a classicist typeface with a high stroke weight difference and light serifs.

! abc c c d e e f f g g

! g h h i i j k l m n o

! p q q r r r s s t u v

! w x y z f t e g s

Blume Stuhl  
grau Katze  
Handy o o b  
Fachklasse gr

n v v v b w i z  
baumign v k n  
j g i g z x x h q e  
l o s s s e n d a v

sunflower  
abcdefghijkl  
mnopqrstuv  
wxyz

Нарек

Нарек

Нарек

Нарек

Нарек

Нарек

Hapeek

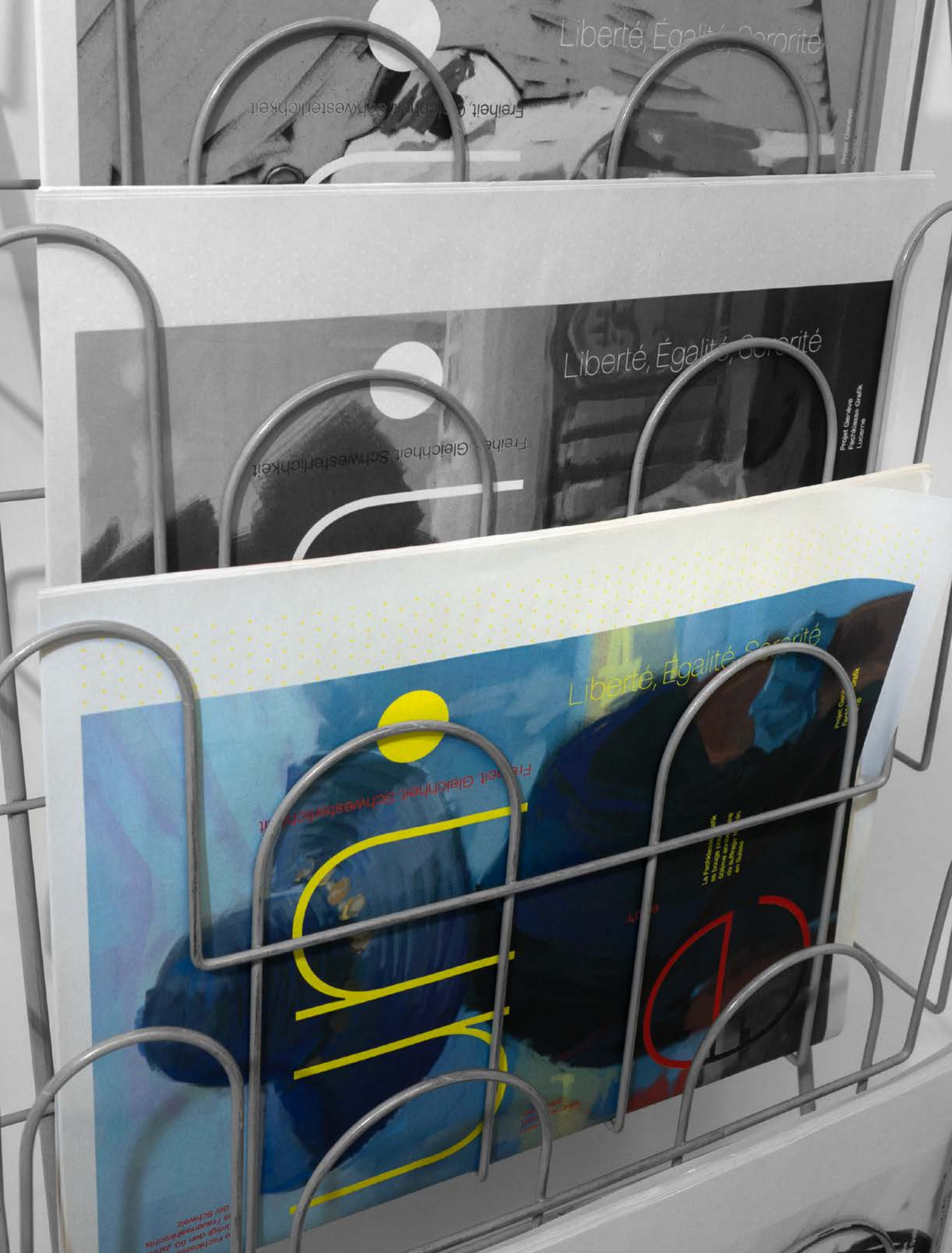

## The Queens are the strongest

Layout, Photography, Drawing

September 2020

During our study trip to Geneva, I spent two weeks in the “Parc de Bastions” near the old town. The chess boards, which were located at the entrance of the park, fascinated me from the very beginning. What is behind the game of chess? Every day I researched, sketched, and photographed on - site. Back in Lucerne, I designed five pages for a newspaper publication with the collected material. My entire layout is based on a chessboard grid. In terms of content, I deal with quotes on the question “Why do more men play chess than women?” It’s about equality, gender stereotypes, sexism and why women are automatically labelled the weaker sex. In chess, paradoxically, the king is not the strongest piece, but the queen.

## Les dames sont les plus fortes.

Pensez-vous que les échecs étaient un simple jeu ? Non, c'est bien plus que ça et surtout le miroir de la vie passée et présente. Aux échecs, il y a un roi, deux fous, deux cavaliers, deux tours, huit pions et une seule dame.

Dans le Parc des Bastions à Genève, ce n'est pas très différent et j'ai surtout observé que seuls les hommes jouaient aux échecs. Les hommes sont-ils meilleurs et plus forts aux échecs ? Dans le jeu d'échecs lui-même, ce n'est pas le roi qui est la pièce la plus forte, mais la dame. Néanmoins, le roi est toujours plus haut dans la hiérarchie du pouvoir que la dame. Cette image se reflète encore aujourd'hui dans notre société et l'homme est encore supérieur à la femme dans certains domaines.

En partant de la question : « Pourquoi les hommes sont-ils plus nombreux que les femmes à jouer aux

échecs », vous en apprenez beaucoup sur l'égalité, les stéréotypes sexistes, le sexisme et la question de savoir pourquoi les femmes sont automatiquement appelées le sexe faible. Ensemble, elles sont fortes et ont acquis de nombreux droits au cours des dernières décennies, et cette lutte est loin d'être terminée.

© Le Mur des Réformateurs dans le Parc des Bastions  
Das Reformationsdenkmal im Parc des Bastions

## Die Damen sind die stärksten

Dachten Sie, Schach ist nur ein einfaches Spiel? Nein, es ist so viel mehr und vor allem der Spiegel des Lebens in der Vergangenheit, sowie auch in der Gegenwart. Im Schach gibt es einen König, zwei Läufer, zwei Springer, zwei Türme, acht Bauern und nur eine Dame.

Im Genfer Parc des Bastions ist es nicht viel anders und ich beobachtete mehrheitlich nur Männer, welche Schach spielten. Sind Männer besser und stärker im Schach? Im Schachspiel selbst ist nämlich nicht der König die stärkste Figur, sondern die Dame. Der König ist dennoch in der Machthierarchie immer höhergestellt als die Dame. Dieses Bild spiegelt sich bis heute auch in unserer Gesellschaft wider und der Mann ist immer noch in einigen Bereichen der Frau übergeordnet.

Anhand von Zitaten zur Frage: «Warum spielen mehr Männer Schach als Frauen?», erfahren Sie in meiner Projektarbeit viel über Gleichberechtigung, Geschlechtsstereotypen, Sexismus und die Frage, warum Frauen automatisch als das schwächere Geschlecht bezeichnet werden. Denn Frauen sind alles andere als schwach. Sie sind gemeinsam stark und erstritten sich in den vergangenen Jahrzehnten viele Rechte und dieser Kampf ist noch lange nicht beendet.

# Les dames sont plus fortes

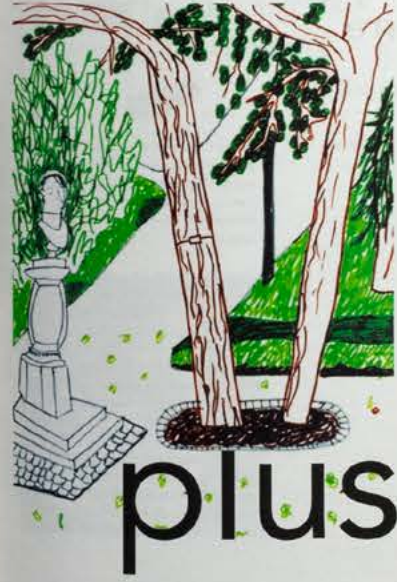

Le Parc des Bastions comme jeu d'échecs

Pensez-vous que les échecs étaient un simple jeu ? Non, c'est bien plus que ça et surtout le miroir de la vie passée et présente. En citant la question : « Pourquoi les hommes sont-ils plus nombreux que les femmes à jouer aux échecs », ils en apprennent beaucoup sur l'égalité, les stéréotypes sexistes, le sexisme et la question de savoir pourquoi les femmes sont automatiquement appelées le sexe faible.

Chiara Huber

# Les échecs sont-ils le miroir de la vie ?

Aux échecs, il y a un roi, deux fous, deux cavaliers, deux tours, huit pions et une seule dame.

Dans le Parc des Bastions de Genève, ce n'est pas très différent. J'ai observé les jeux d'échecs en plein air échecs du parc pendant presque deux semaines et rapidement, je me suis rendu compte que pratiquement seuls les hommes jouaient ici aux échecs. Des hommes en costume ou des touristes mais aucune femme.

Les hommes ont monopolisé chaque jour les six échiquiers à l'entrée du parc. Seules quelques femmes ont osé jouer ou ont apprécié le jeu de dames à côté des échiquiers. Les femmes se sentent-elles obligées de jouer aux dames parce que le jeu porte leur nom ou parce que le jeu de dames est subordonné aux échecs ?

« Pourquoi les hommes sont-ils plus nombreux que les femmes à jouer aux échecs ? » Cette question occupait mon esprit. La meilleure façon d'obtenir une réponse à ma question était de demander directement l'avis des joueurs d'échecs locaux. J'ai reçu des réponses et des arguments intéressants, et qui m'ont fait réfléchir.



06.09.2020 14:50

09.09.2020 14:28



09.09.2020 14:29



12.09.2020 13:04



12.09.2020 13:08



## « C'est un jeu de guerre et de combat. »

Joueur d'échecs cubain



08.09.2020 12:33

Les échecs sont un jeu dans lequel la logique et la stratégie sont les principaux enjeux. Mais dès sa conception, les échecs sont un jeu de guerre et de combat, car deux armées hostiles sont en guerre l'une contre l'autre.

Dans nos esprits, il y a encore une image forte du passé : la guerre est l'affaire des hommes. Les femmes peuvent aider mais pas se battre. D'une certaine manière, il y a beaucoup de vérité dans cet argument, car c'est précisément à cause de ce modèle que beaucoup de femmes ne peuvent probablement pas s'identifier facilement aux jeux de guerre.

Mais les femmes se sont battues pour de nombreux droits au cours des dernières décennies. Ensemble elles sont fortes et elles peuvent donc très bien se battre !

### Les échecs :

Le nom d'échecs est dérivé du « Shah » (roi) persan, d'où le nom de « jeu royal ». Le but du jeu est de mettre l'adversaire en échec et mat. C'est-à-dire attaquer son roi de telle manière qu'il ne lui est pas possible de se défendre ou de s'échapper.

### Parc des Bastions :

Près de la vieille ville se trouve le Parc des Bastions, un grand espace vert au centre de la ville. Le long des avenues ombragées, on peut parfaitement se promener et admirer le monument impressionnant de la Réformation. Le Palais Eynard, la grande bibliothèque de Genève et l'Université de Genève y sont également situés.

### Jeu de dames :

Le jeu de dames est un jeu de plateau stratégique et ressemble beaucoup aux échecs, il est donc également joué sur le même plateau. L'objectif est de prendre les pions de l'adversaire en sautant par-dessus ses pièces. Le perdant est celui qui n'a plus de pions ou qui ne peut pas les déplacer.

Chiara Huber

# « C'est un problème de machisme et de la société patriarcale. »

Joueur d'échecs français



Les hommes ont un pouvoir sur les femmes. Une société patriarcale décrit exactement cette structure. Dans le passé, les hommes étaient le chef de famille et avaient donc le pouvoir. Ils pouvaient opprimer, humilier ou contrôler les femmes. En bref, les hommes ont régné sur les femmes. Mais pourquoi les hommes devraient-ils valoir plus que les femmes !

Dans le Parc des Bastions lui-même, il n'y a qu'une sculpture féminine parmi des dizaines d'hommes. Les réformateurs sont tous des hommes et la seule femme, Marie Dentière, a été cisalée en petit à côté de Zwingli.

Aujourd'hui, cette situation s'est considérablement améliorée, et pourtant, dans de nombreux domaines, l'égalité est encore loin d'être acquise.

06.09.2020 15:25



### Société patriarcale :

Une société patriarcale décrit une structure générale dans laquelle les hommes ont un pouvoir sur les femmes. Les hommes ont plus de privilèges et sont supérieurs aux femmes. Le contraire serait alors le matriarcat. Une autre société dans laquelle les mères et les femmes ont le premier mot à dire.

### Les réformateurs :

Les quatre statues de William Farel, John Calvin, Théodor Bèze et John Knox se trouvent sur le Monument de la Réformation. Ces quatre personnes sont considérées comme les principaux représentants du calvinisme. En face de ce mur se trouve un escalier dans les murs latéraux duquel sont gravés les noms de « Luther » et « Zwingli ».

### Marie Dentière :

Elle est la seule femme honorée au Monument de la Réforme à Genève. Les femmes devaient être autorisées à prêcher comme les hommes. Cette demande est devenue son message central. Elle a publié des écrits théologiques et historiques, est intervenue dans des débats et a lutté pour l'égalité des droits entre les hommes et les femmes.

Les dames sont les plus fortes

# « Les femmes sont comme des renards. Elles sont trop intelligentes. »

Joueur d'échecs mexicain



Est-ce la raison pour laquelle les femmes ont été autorisées à étudier et à enseigner dans les universités si tardivement ? Les hommes ont-ils permis aux femmes d'entrer si tard dans les universités par crainte qu'elles ne deviennent plus intelligentes ? Mais en réalité, université signifie « universel », c'est-à-dire « accessible à tous ». Il est certain que si les femmes réussissent dans leur carrière, l'image des stéréotypes sexuels aurait complètement changé. L'homme au fourneau et la femme au travail. Autrefois inimaginable et maintenant tout à fait possible.

Depuis 1864, après de nombreuses années et diverses manifestations, les femmes ont été autorisées à étudier. Le symbole de la femme pulvérisée est encore visible aujourd'hui sur les escaliers de l'Université de Genève.

Aux niveaux hiérarchiques supérieurs, les femmes sont légèrement mieux représentées à Genève que dans les autres universités, et pourtant le nombre de femmes aux niveaux supérieurs diminue sensiblement, alors que les hommes sont représentés en grand nombre. Bien sûr, cela reste lié à la répartition des rôles selon le sexe.

Les femmes doivent choisir soit une carrière, soit une famille. La plupart des femmes choisissent d'avoir des enfants et un foyer, c'est pourquoi elles ne trouvent pas tout le temps nécessaire pour suivre des études supérieures. La répartition des rôles a également changé au fil des ans et aujourd'hui, les femmes ne sont plus les seules responsables des enfants. Elles ne sont plus les seules responsables du ménage et de l'éducation des enfants et vont aussi travailler.

L'égalité en chiffres à l'unige

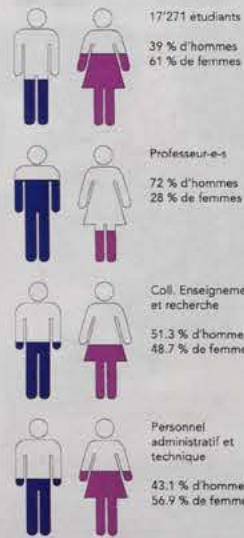

06.09.2020 15:38

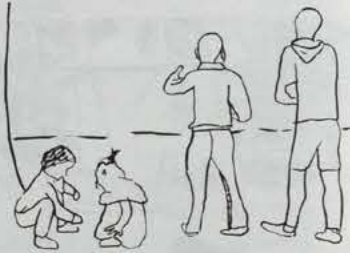

L'université de Genève : L'université de Genève a été fondée par Jean Calvin en 1559 sous le nom d'Académie théologique et humaniste de Genève. Depuis 1980, Genève est la seule université de Suisse où les femmes sont plus nombreuses que les hommes à étudier.

Les stéréotypes sexuels : Les stéréotypes sexistes comprennent, d'une part, des notions simplistes sur la façon dont les femmes et les hommes sont en général et des attentes sur ce qu'ils devraient et ne devraient pas être.

Le symbole de la femme : Le pouvoir féminin, la force, l'indépendance, l'autodétermination. Avec le début du nouveau mouvement des femmes dans les années 1970, le signe de femme est devenu le symbole et l'expression des féministes et des lesbiennes. Le symbole est un poing serré au centre du signe de Vénus.

Les dames sont les plus fortes

# Un regard plus attentif sur les pièces d'échecs.



**La dame**  
Le roi est la pièce la plus puissante et la plus dangereuse des échecs. Elle peut se déplacer horizontalement, verticalement et en diagonale, mais ne peut sauter par-dessus les pièces. Elle est l'allée la plus précieuse de son roi et l'ennemi le plus puissant de son adversaire.



**Le fou**  
Le fou ressemble au pion, mais il est beaucoup plus grand. Il peut se déplacer d'autant de cases en diagonale qu'il le souhaite, mais il ne peut sauter aucune pièce. L'évêque ne peut pas changer de couleur de case.

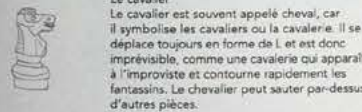

**Le cavalier**  
Le cavalier est souvent appelé cheval, car il symbolise les cavaliers ou la cavalerie. Il se déplace toujours en forme de L et est donc imprévisible, comme une cavalerie qui apparaît à l'improviste et contourne rapidement les fantassins. Le cavalier peut sauter par-dessus d'autres pièces.

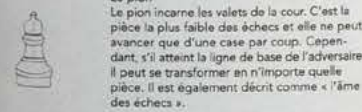

**Le pion**  
Le pion incarne les valets de la cour. C'est la pièce la plus faible des échecs et elle ne peut avancer que d'une case par coup. Cependant, s'il atteint la ligne de base de l'adversaire, il peut se transformer en n'importe quelle pièce. Il est également décrit comme « l'âme des échecs ».

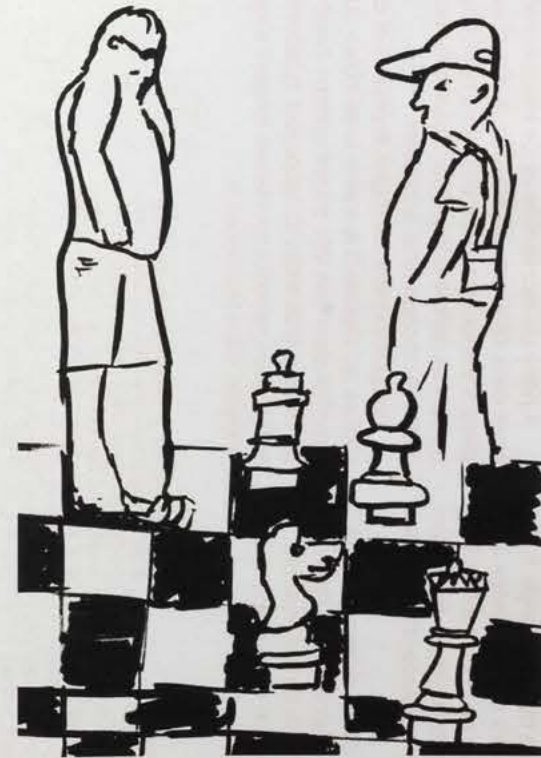

Chiara Huber  
© Fachklasse Grafik Luzern 2020  
Sources textuelles :  
www.unige.ch  
www.greelane.com  
www.geneve.com  
www.wikipedia.org  
www.spielzart.ch  
www.bzw.weiterdenken.de

Chiara Huber



Elia Boccia



Elia Boccia

plus

dan

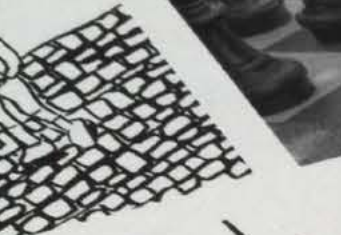

elles

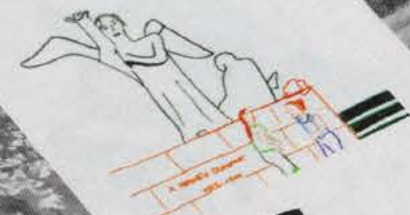
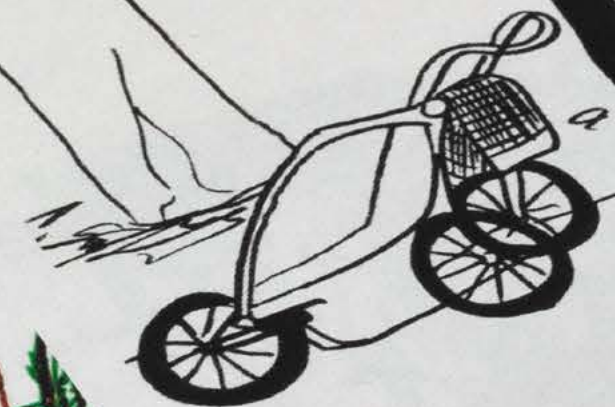

fortes

Pensez-vous que les échecs étaient un simple jeu ? Non, c'est bien plus que ça et surtout le miroir de la vie passée et présente. En citant la question : « Pourquoi les hommes sont-ils plus nombreux que les femmes à jouer aux échecs », ils en apprennent beaucoup sur l'égalité, les stéréotypes sexistes, le sexisme et la question de savoir pourquoi les femmes sont automatiquement appelées le sexe faible.

Charara  
Huber



« un roi, deux fous, deux  
urs, huit pions et une

« Bastions de Genève,  
Brens. J'ai observé les jeux  
d'échecs du parc pen-  
sant que pratiquement  
seulement, des hommes  
se ou des touristes mais  
inoposé chaque jour les  
trée du parc. Seules  
it osé jouer ou ont app-  
e sentent-elles obligées  
arce que le jeu porte  
ue le jeu de dames est  
es ?

es sont-ils plus nom-  
à jouer aux éch-  
occupait mon esprit.  
tenir une réponse  
demander directement  
ces locaux. J'ai reçu  
uments intéressants,  
ir.

## « C'est un jeu de guerre et de combat. »

Joueur d'échecs cubain

08.09.2020  
12:33



09.09.2020  
14:29



12.09.2020  
13:04



12.09.2020  
13:08



Les échecs sont un jeu dans lequel la lo-  
gique et la stratégie sont les principaux  
enjeux. Mais dès sa conception, les échecs  
sont un jeu de guerre et de combat, car  
deux armées hostiles sont en guerre l'une  
contre l'autre.

Dans nos esprits, il y a encore une image  
forte du passé : la guerre est l'affaire des  
hommes. Les femmes peuvent aider mais  
pas se battre. D'une certaine manière,  
il y a beaucoup de vérité dans cet argument,  
car c'est précisément à cause de ce mo-  
dèle que beaucoup de femmes ne peuvent  
probablement pas s'identifier facilement  
aux jeux de guerre.

Mais les femmes se sont battues pour de  
nombreux droits au cours des dernières  
décennies. Ensemble elles sont fortes et elle  
peuvent donc très bien se battre !



L'égalité en chiffres  
à l'unige

17'271 étudiants  
39 % d'hommes  
61 % de femmes

Professeur-e-s  
72 % d'hommes  
28 % de femmes

Coll. Enseignement  
et recherche  
51.3 % d'hommes  
48.7 % de femmes

Personnel  
administratif et  
technique  
43.1 % d'hommes  
56.9 % de femmes

elles sont  
fortes

Université de Genève :  
de Genève a été fondée par Jean  
le nom d'Académie  
de Genève. Depuis  
Université de  
heures

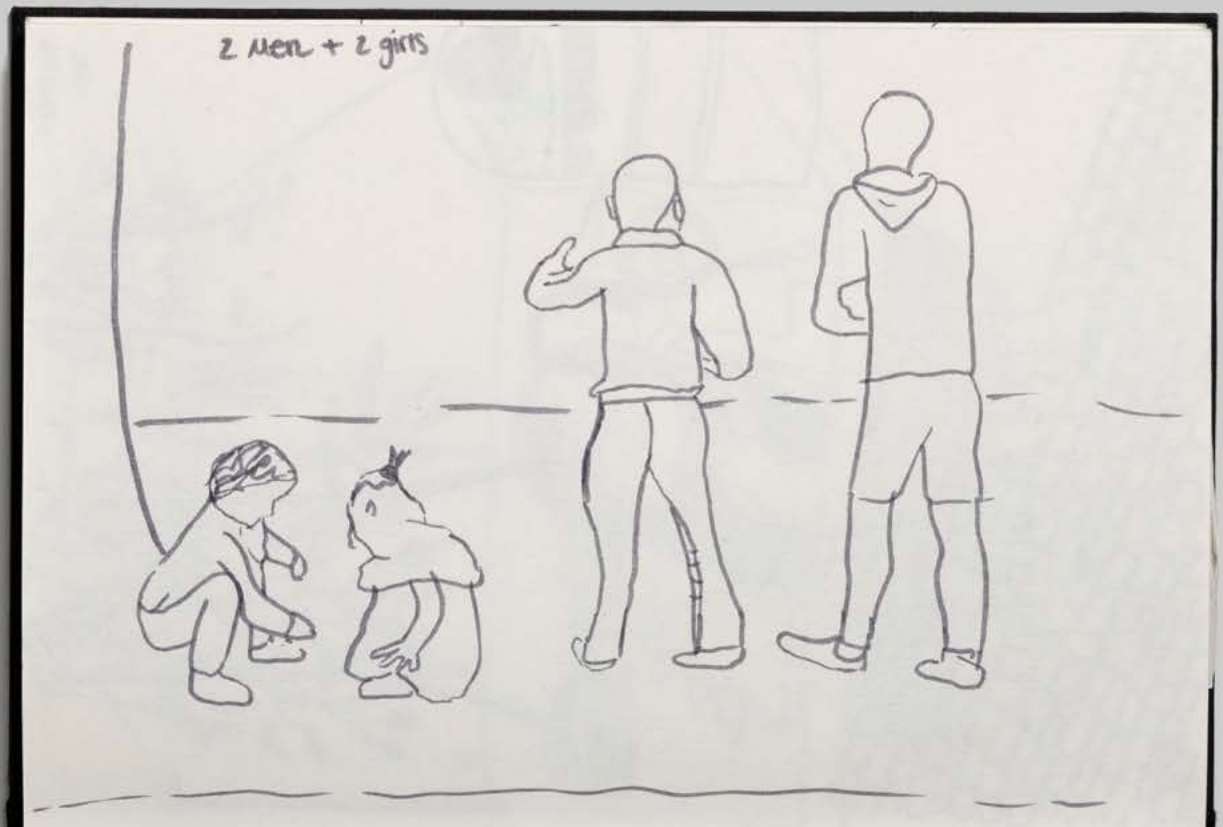

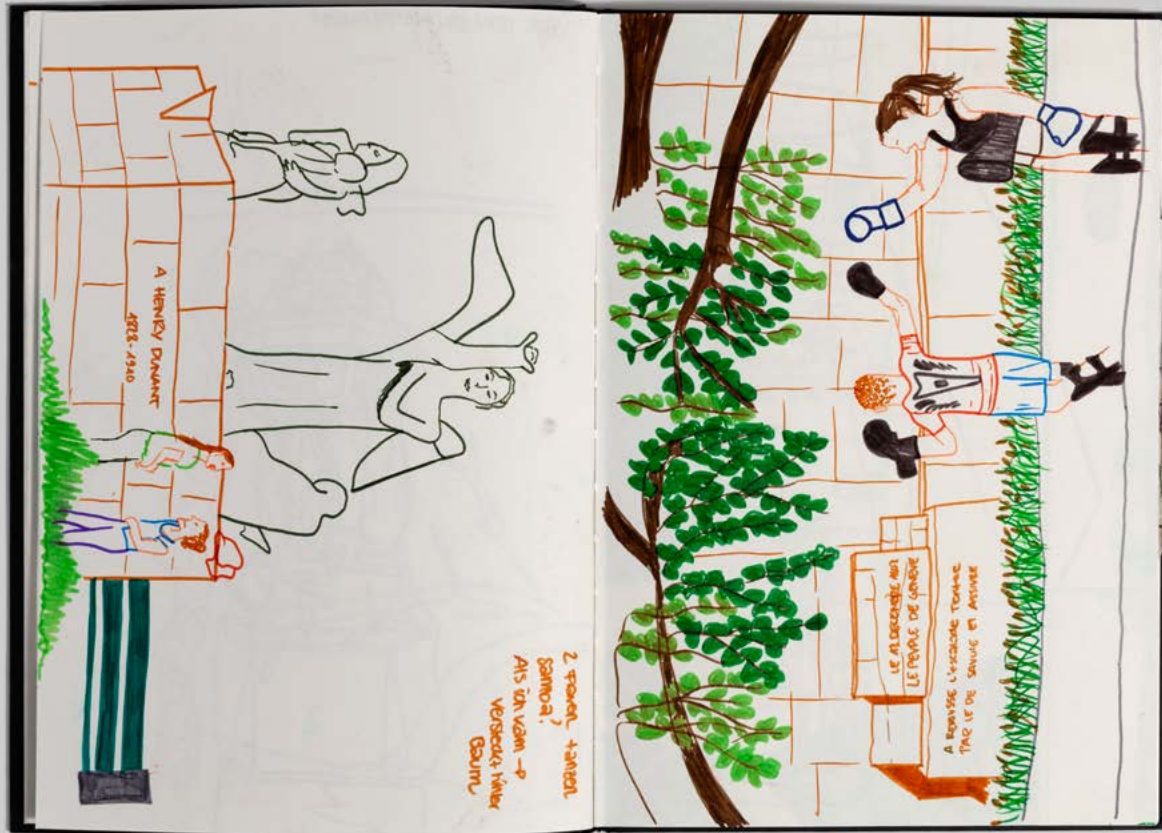

Universität Genéve

Hier, hat die Homophobie viele Opfer gemacht! → Striker auf Boden

- **« Ici, l'homophobie a fait une victime. »**
- **homophobie** → Aggressivität gegen lesbische + schwule Personen.
- #UNI UNIF **contre le harcèlement** gegen Belästigung
- [www.unige.ch](http://www.unige.ch) université genéve
- espace alléiement → Strubum?

**AGIR QUAND ON SE SENT MENACÉ(E)**

Qu'est-ce qu'une menace?  
Parole, écrit, geste ou comportement menaçants, visant une personne en particulier et inspirant un sentiment d'insécurité, même sans danger imminent. Une menace non prise en charge pourrait aboutir ultérieurement à un acte de violence. Tout membre de la communauté universitaire se sentant personnellement menacé ou ayant connaissance de menaces proférées ou pressenties au sein de la communauté universitaire peut écrire à : [respect@unige.ch](mailto:respect@unige.ch)

En présence d'une **menace précise et imminente** (attaque à main armée, prise d'otage, séquestration, menace de suicide imminent, etc.), appeler immédiatement le 117 puis avérir la sécurité interne au 1222.

Pour en savoir plus : [www.unige.ch/respect](http://www.unige.ch/respect)

UNIVERSITÉ DE GENÈVE

SANTÉ AU TRAVAIL, ENVIRONNEMENT, PRÉVENTION, SÉCURITÉ

Veränderung mit großer Erfahrung





## Anamorphosis

Photography, Film, Typography

June 2021

Weltformat Graphic Design Festival

In collaboration with Arno Röthlin and Elena Kaeslin, I shot a short film and designed posters for the “Weltklasse” workshops, which are organised each year by the “Fachklasse Grafik Lucerne” as part of the “Weltformat Graphic Design Festival”. We were interested in the topic of anamorphosis, more precisely with the perception of a word from a very specific angle. For this purpose, we constructed an anamorphic installation out of self - made objects.

**Link to the video: <https://chiarahuber.ch/projects/anamorphose/index.html>**



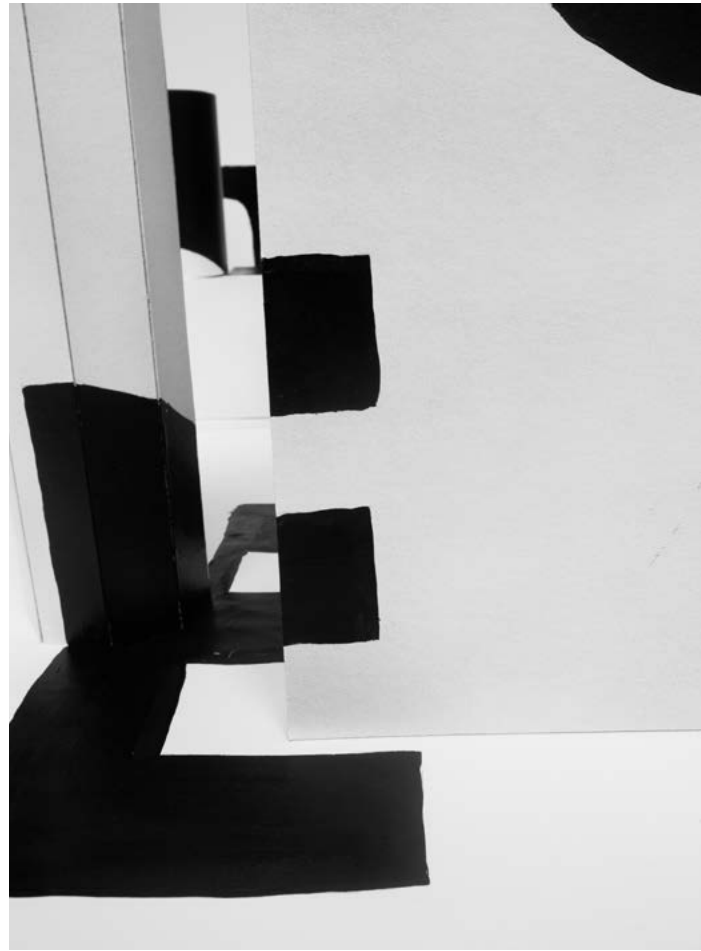
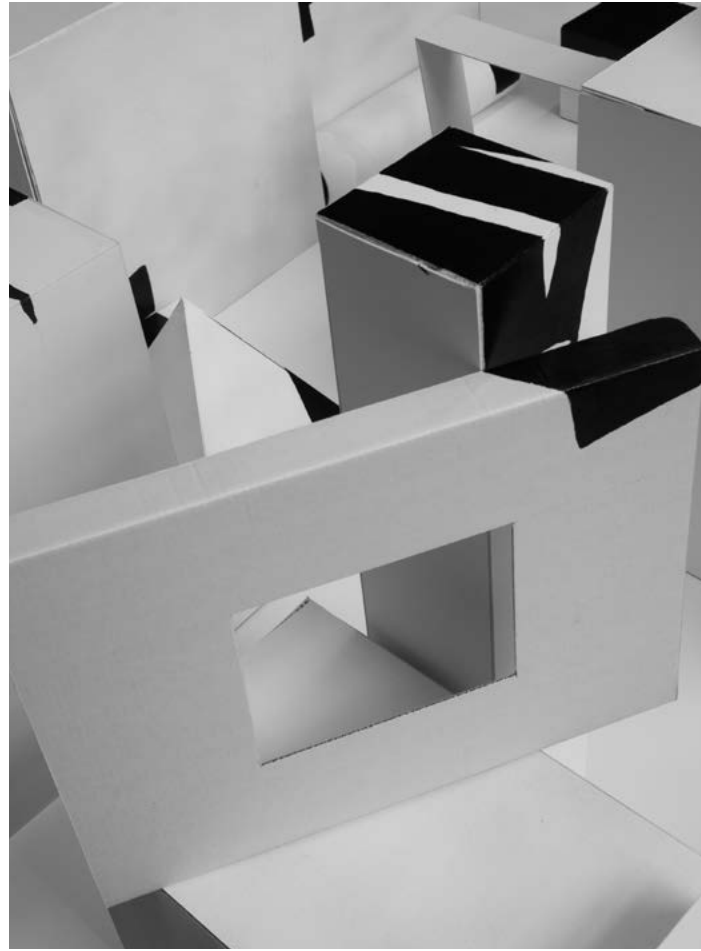

0123456789  
abcdefghijklmnop  
qrstuvwxyzäöü.,-'

es gibt mittlerweile codes, die besser als die schriftzeichen informationen übermitteln. was bisher geschrieben wurde kann besser auf tonbänder, schallplatten, filme, videobänder, bildplatten oder disketten übertragen werden. und vieles was bislang nicht geschrieben werden konnte, ist in diesen neuen codes notierbar. die derart codierten informationen sind bequemer zu erzeugen, zu übertragen, zu empfangen und zu speichern als geschriebene texte.

schreiben im sinne einer aneinanderreihung von buchstaben und anderen schriftzeichen scheint kaum oder überhaupt keine zukunft zu haben. es gibt mittlerweile codes, die besser als die schriftzeichen informationen übermitteln. was bisher geschrieben wurde kann besser auf tonbänder, schallplatten, filme, videobänder, bildplatten oder disketten übertragen werden. und vieles was bislang nicht geschrieben werden konnte, ist in diesen neuen codes notierbar. die derart codierten informationen sind bequemer zu erzeugen, zu übertragen, zu empfangen und zu speichern als geschriebene texte.

### Lens font

Illustration, Font Design  
January 2020

To familiarise ourselves with the Adobe Illustrator programme, we disassembled and analysed an electronic device. I decided to use my old photo camera and as a first step, I made a digital inventory. A deconstruction resulted in many exciting shapes, and I created some first letters from them. Finally, in an exciting process, I derived the design of my sans serif font "lens" from the individual parts of the lens.

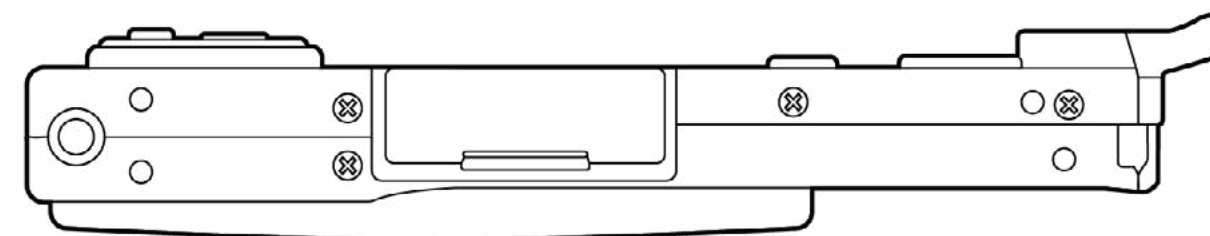
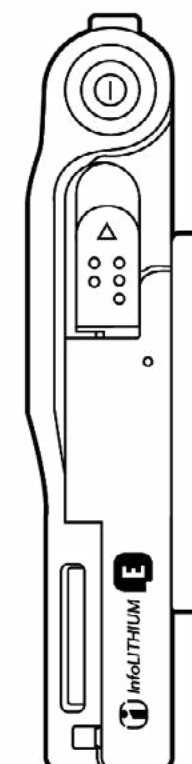
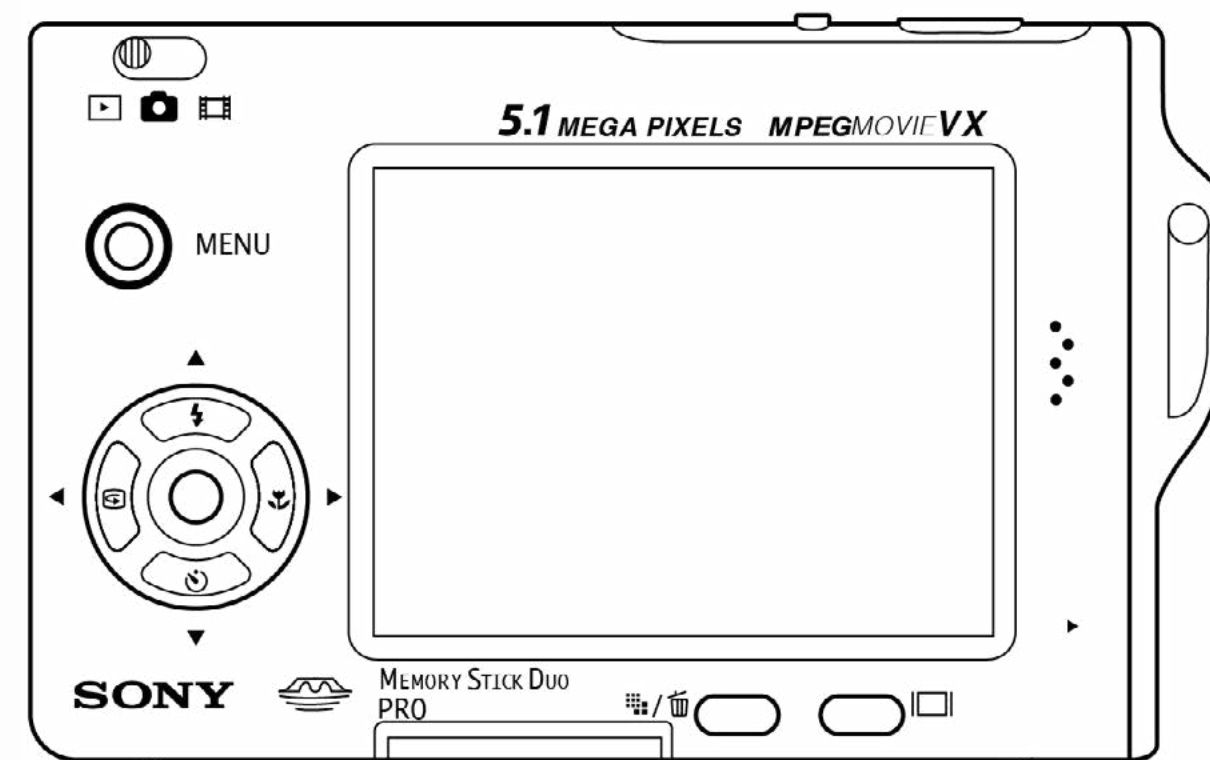
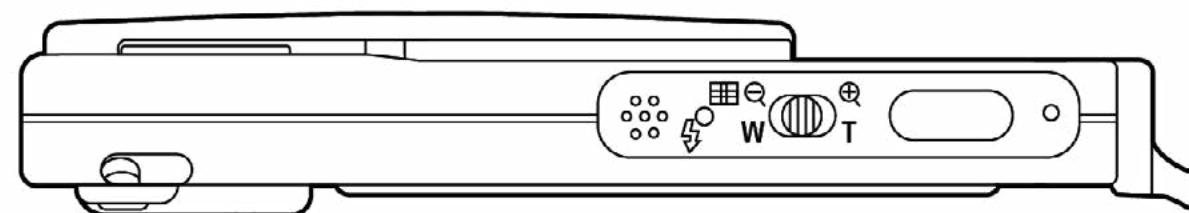
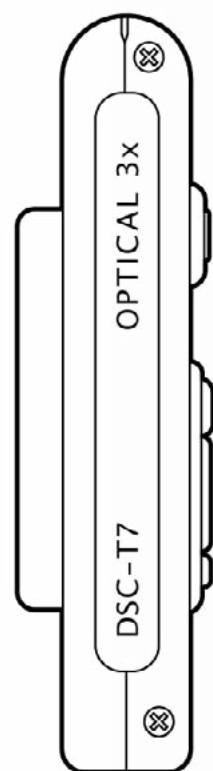
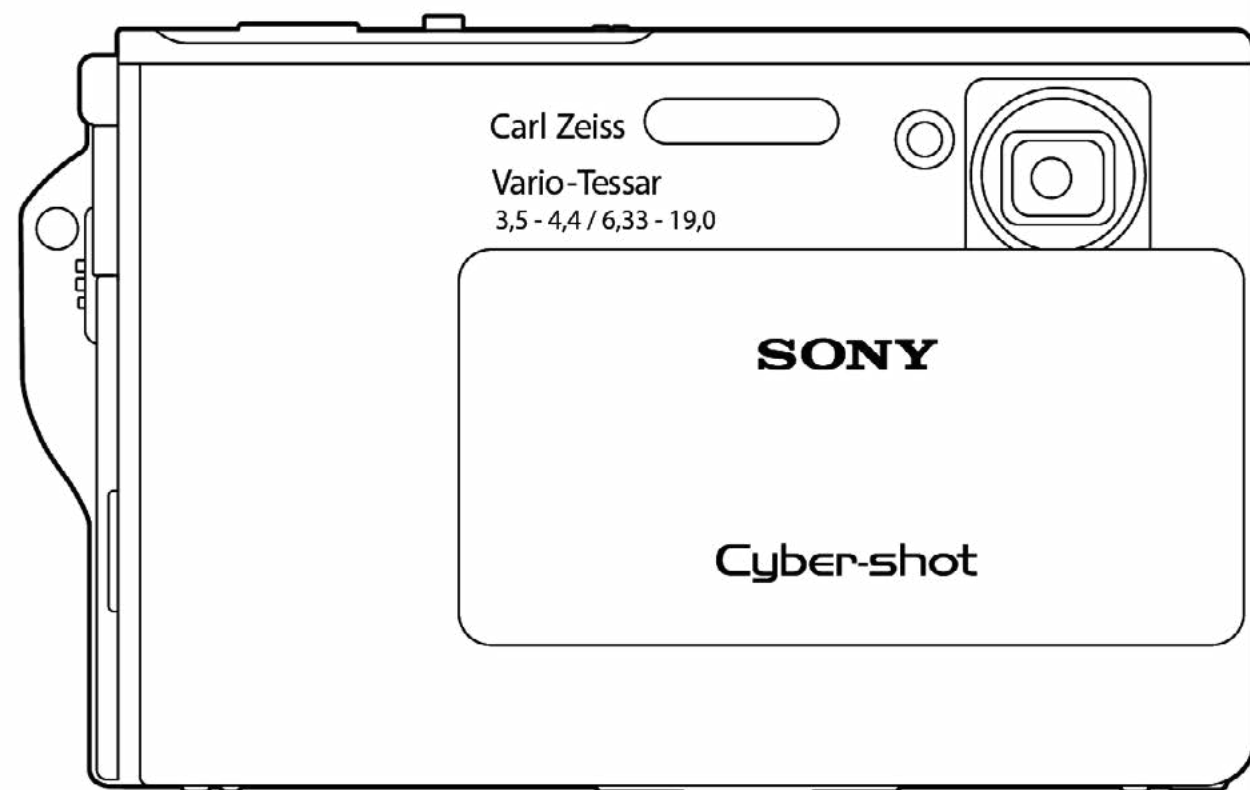

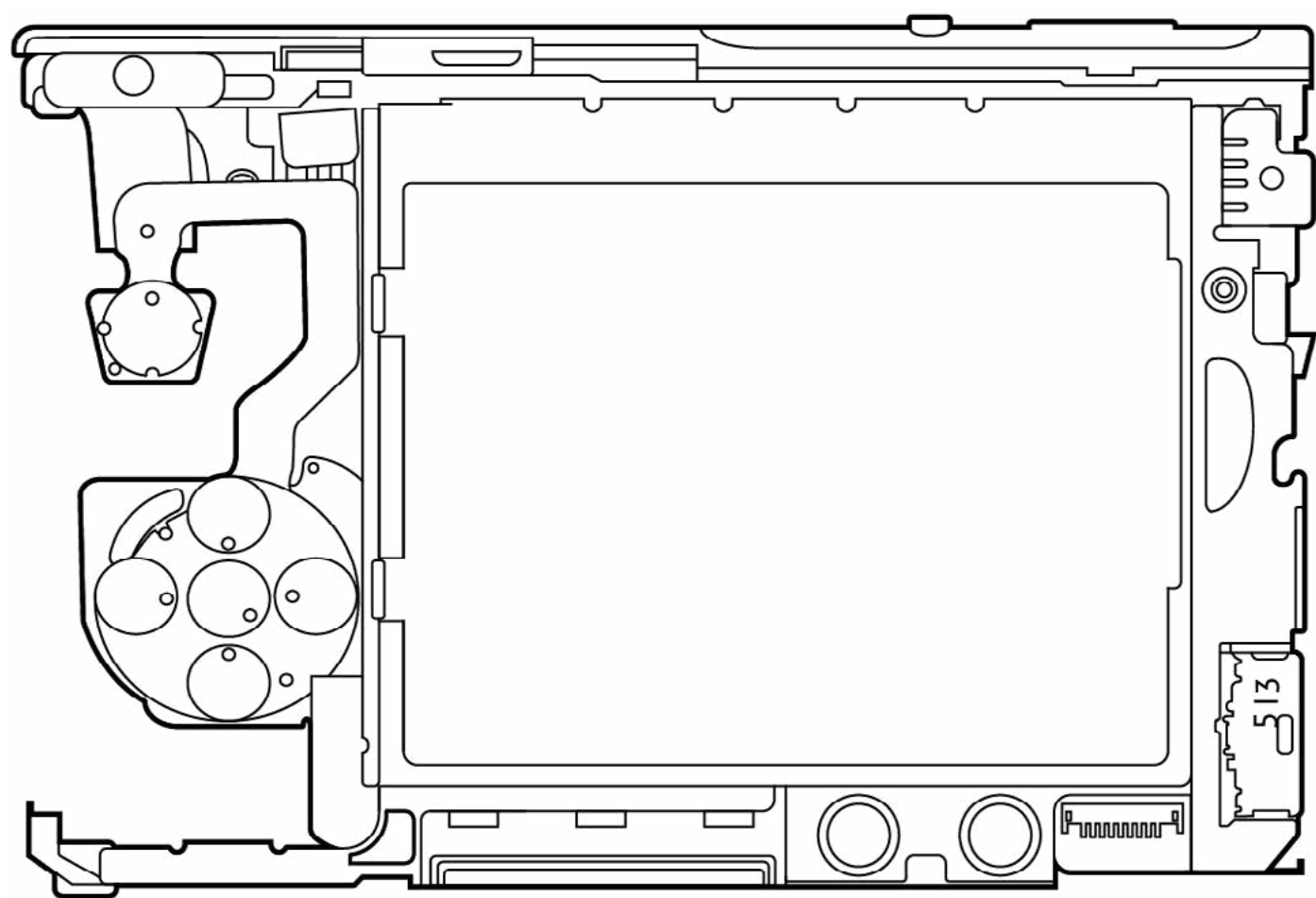
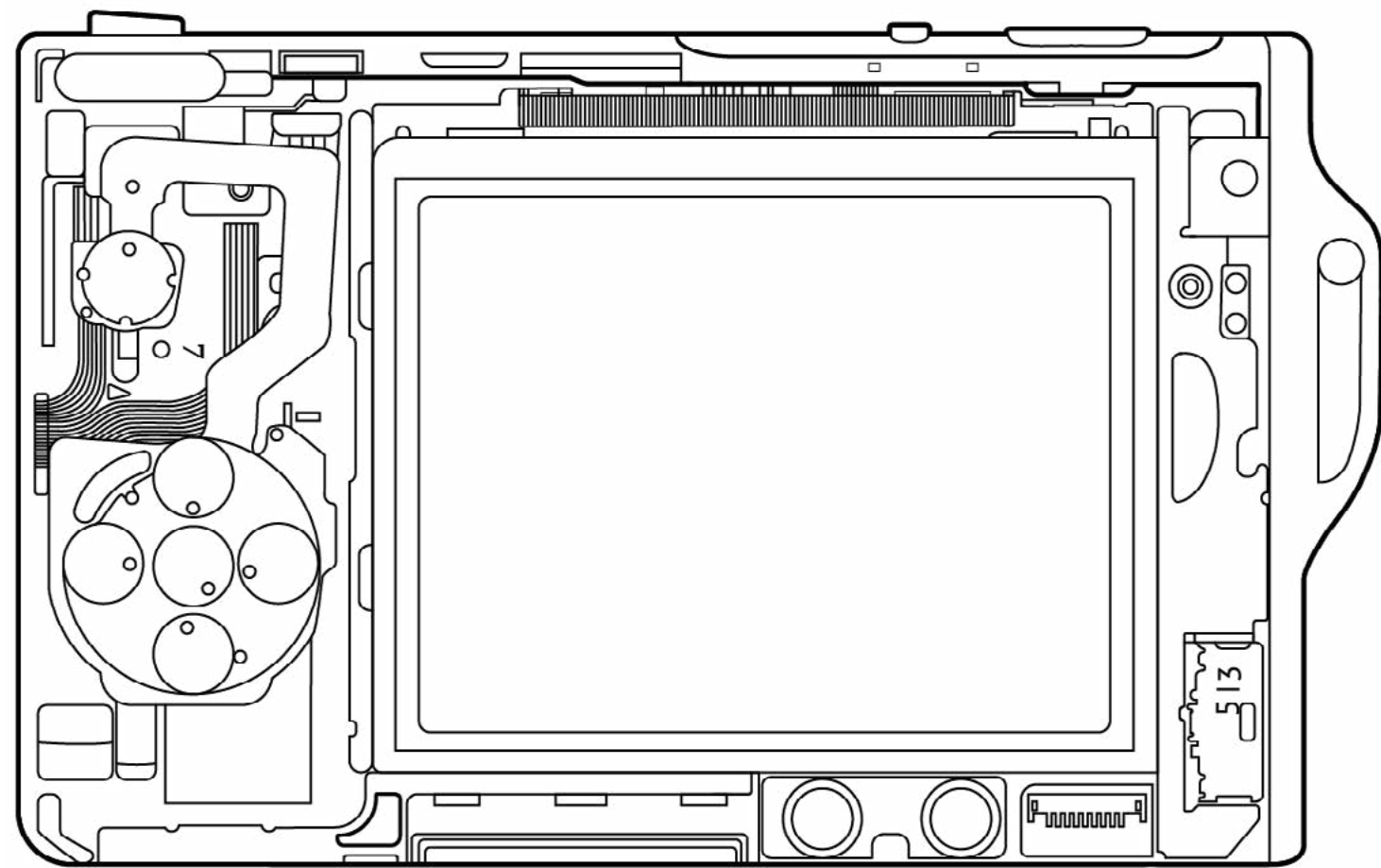
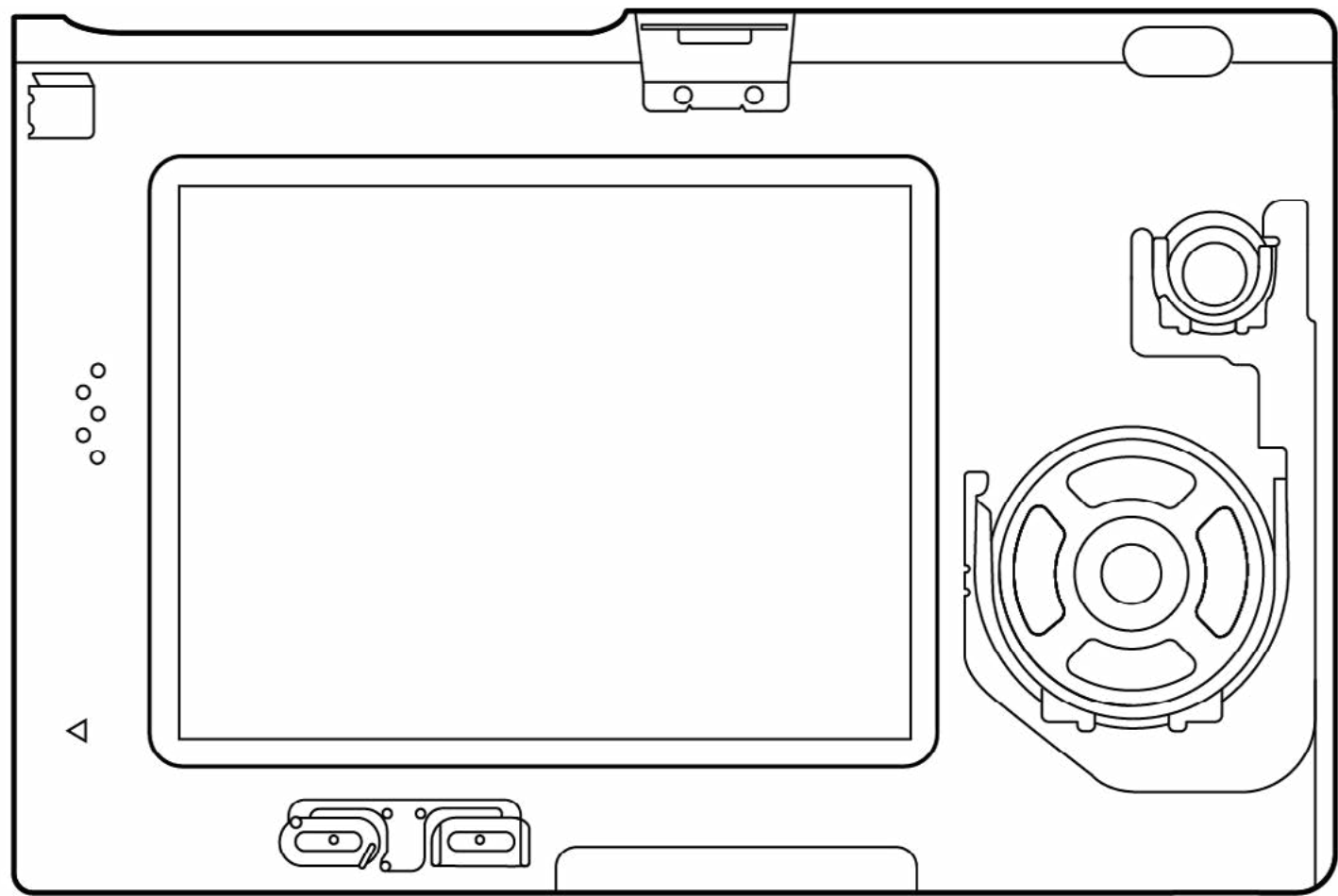

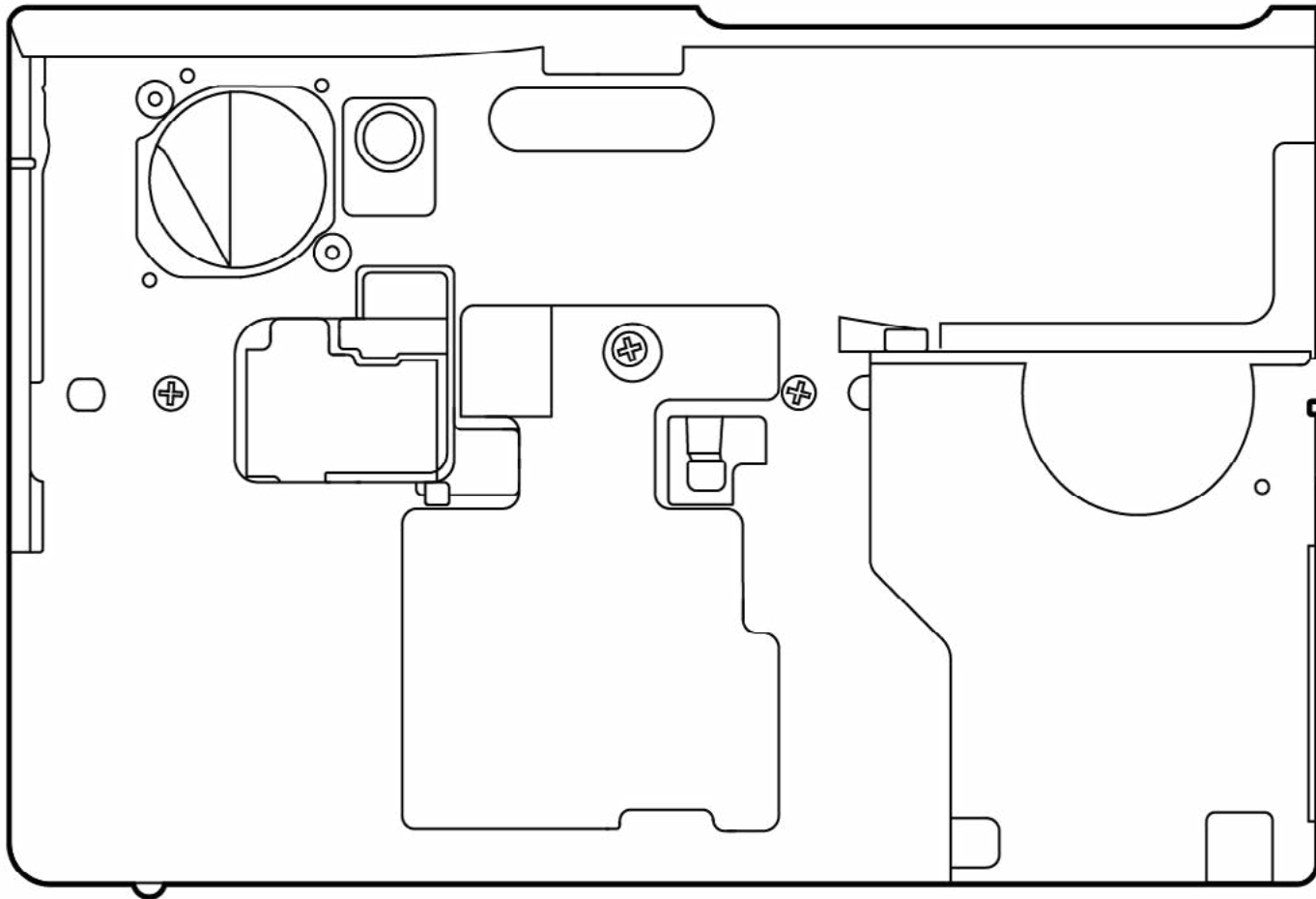
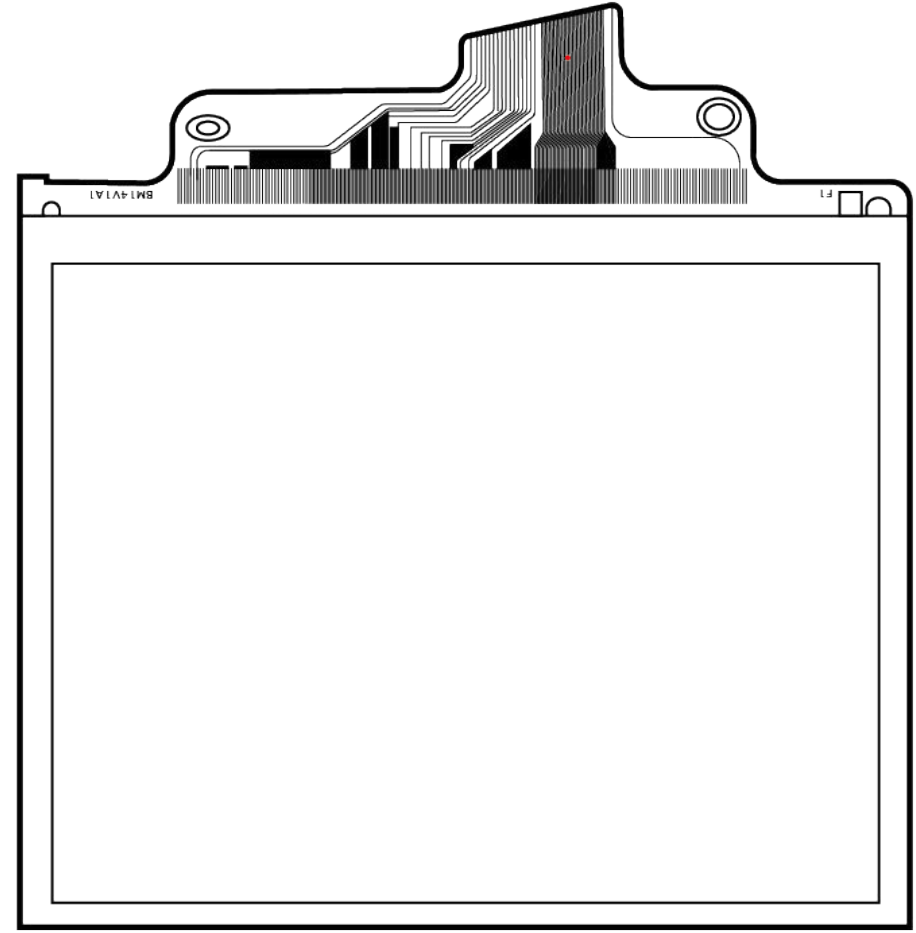
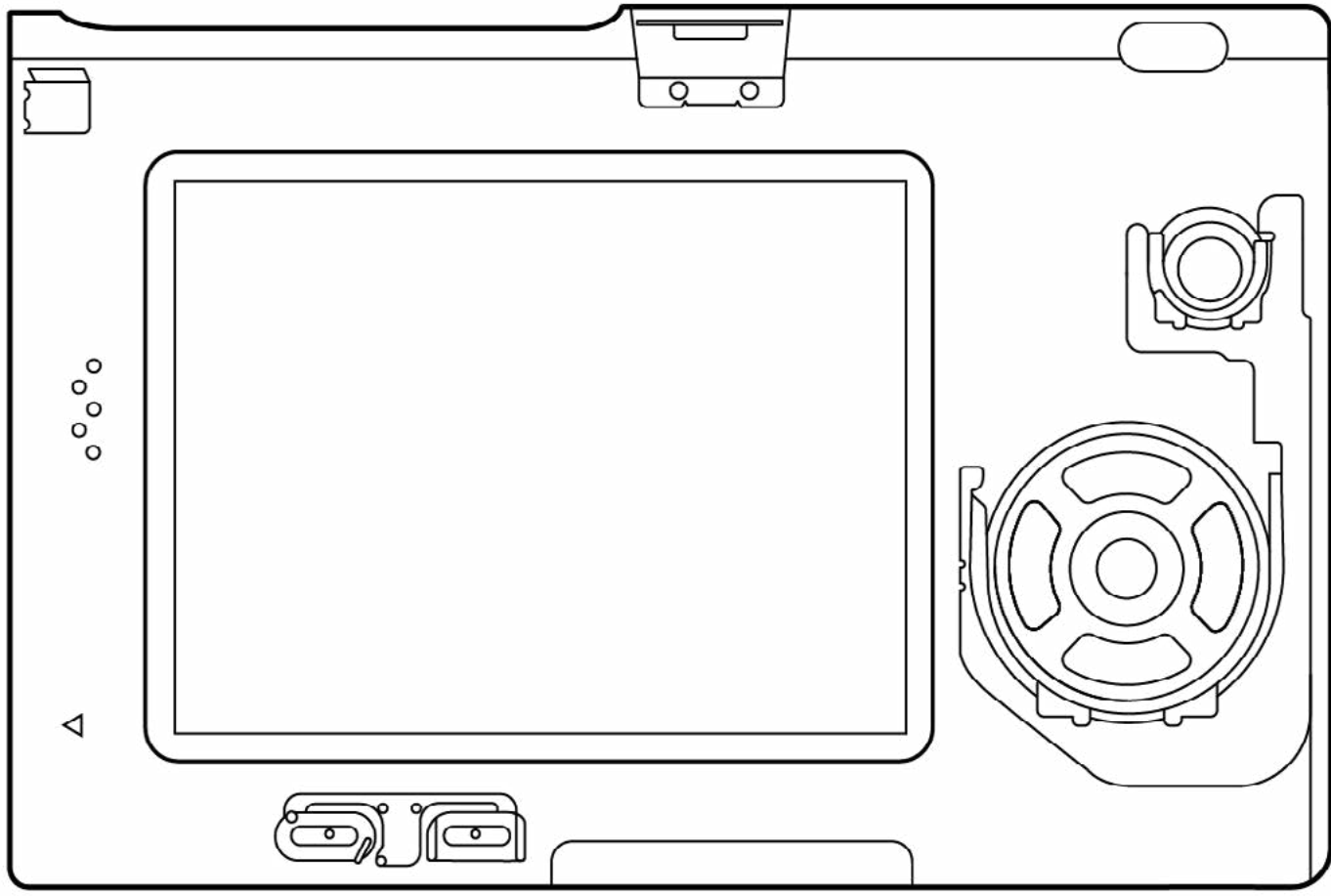

ycug y  
eor dinm

bcdb pore  
niu s

kdopin

qpdhnm  
coi

drop core

drop core

drop core

drop core

drop

drop

drop core

drop core

0 1 2 3 4 5 6 8 9

a b c d e f g h i j k l m

n o p q r s t u v w x y z

ä ö ü . - , @ ®

## Stressful Mornings

Illustration, Vector

November 2020



The task was to record the sound of a device using sampling and to design a record cover to match. I chose an old children's alarm clock. I disassembled it into its individual parts and from the sounds that these parts emitted, I created my sound "Early Mornings". Then I designed two versions of a record cover. I vectorised the individual parts of the alarm clock in Illustrator and concentrated on the pitches and tone lengths of the parts used in the design.



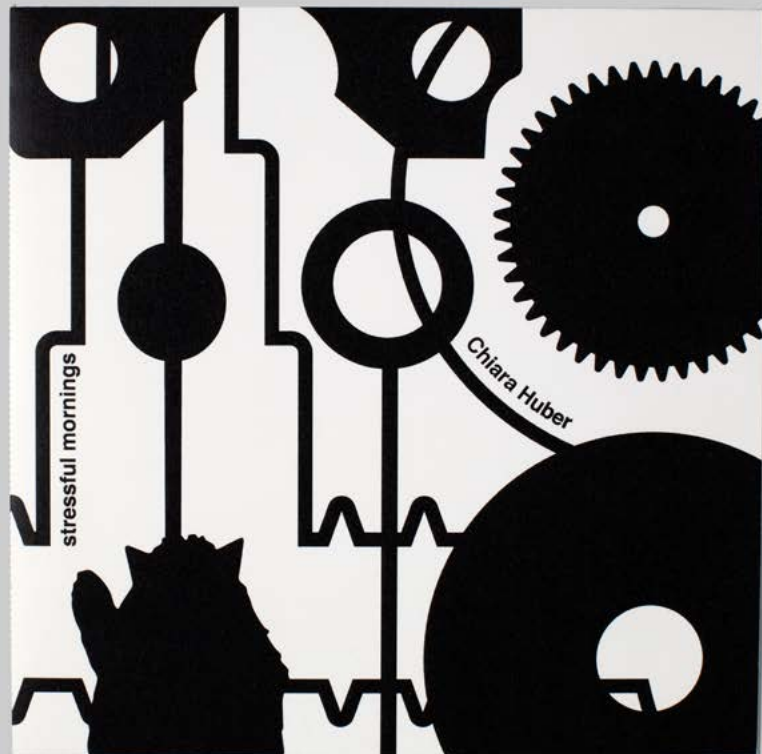
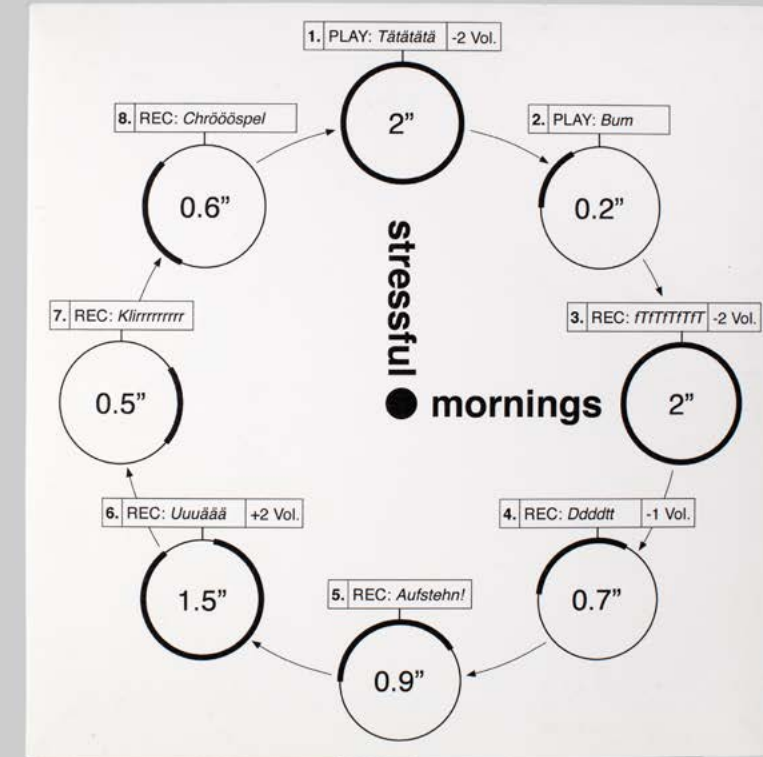

**Chiara Huber**

Graphic Designer  
May 2004  
huberchiara@gmx.ch  
chiarahuber.ch

**Programs**

Indesign: very good  
Photoshop: good  
Illustrator: good  
Adobe Lightroom: good  
Adobe XD: basic  
Glyphs: basic  
Html, CSS: basic

**Languages**

German: very good  
English: good  
French: good

I'm Chiara Huber, 17 years old, and I'm currently in my third year of studies to become a graphic designer at the "Fachklasse Grafik Lucerne". My interests lie mainly in layout, typography, font design, as well as photography. I am a very structured and organised person and love to come up with new design concepts. I'm very interested in working in detail and am always fascinated by the great effect even the smallest interventions can achieve. In my free time, baking is my passion, where I can give free rein to my creativity. I enjoy experimenting and being inspired by new recipes. I also enjoy spending time with my family and friends. Otherwise, I always enjoy immersing myself in a good book with a cup of tea and chocolate chip cookies.